

EVAPCO, INC.



| | | | | | | |
|-------------------------------|--------------------------------|-----------------|-----------------------------|-----------|-------------------|----------|
| UNIT EVAPORATIVE CONDENSER | MODEL # ATC-DC-1220N-35-2EF | SCALE N.T.S. | DWG. # EGCH122004-DRB-ST | REV. - | DATE 4/29/2026 | SERIAL # |
|-------------------------------|--------------------------------|-----------------|-----------------------------|-----------|-------------------|----------|

- NOTES:
- (M)- FAN MOTOR LOCATION
 - HEAVIEST SECTION IS COIL SECTION
 - MPT DENOTES MALE PIPE THREAD
FPT DENOTES FEMALE PIPE THREAD
BFW DENOTES BEVELED FOR WELDING
 - +UNIT WEIGHT DOES NOT INCLUDE ACCESSORIES (SEE ACCESSORY DRAWINGS)
 - MAKE-UP WATER PRESSURE
20 psi MIN [137 kPa], 50 psi MAX [344 kPa]

- DIMENSIONS LISTED AS FOLLOWS:
ENGLISH IN
[METRIC] [mm]
- * - APPROXIMATE DIMENSIONS DO NOT USE FOR PRE-FABRICATION OF CONNECTING PIPING.

**FACE 2
PLAN VIEW**

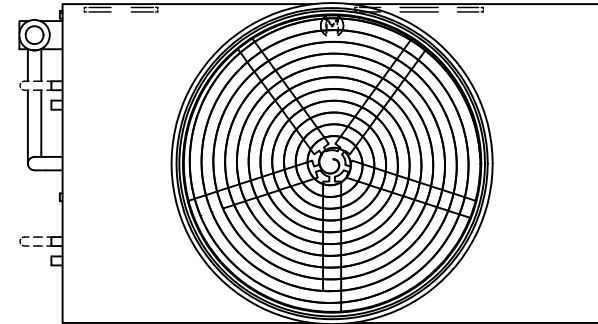

FACE 1

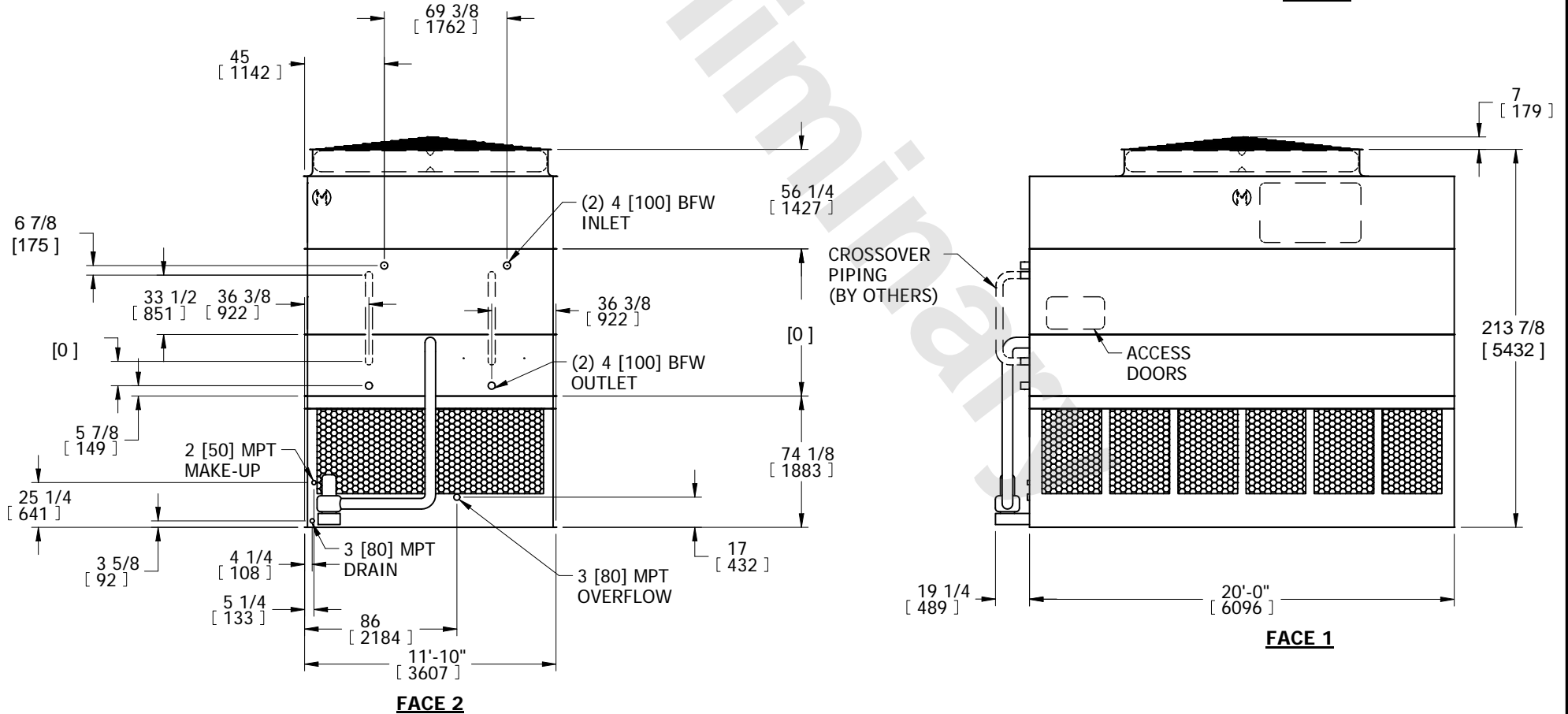

FACE 2

FACE 1

| | | | | |
|---|--|---|-------------------------------|------------------|
| SHIPPING WEIGHT 34390 lbs+ [15600] kg+ | OPERATING WEIGHT 45180 lbs+ [20495] kg+ | HEAVIEST SECTION WEIGHT 25790 lbs+ [11700] kg+ | NO. OF SHIPPING SECTIONS 3 | DRAWN BY: SFR |
|---|--|---|-------------------------------|------------------|