

UNIT	CLOSED CIRCUIT COOLER	
MODEL #	ATWB 14-3J14-Z	SCALE NTS

EVAPCO, INC.

DWG. #	CW4C141406-DRB-ST	REV	-
SERIAL #		DATE:	6/27/2026

NOTES

- (M)- FAN MOTOR LOCATION
- HEAVIEST SECTION IS FAN/CASING SECTION
- MPT DENOTES MALE PIPE THREAD
FPT DENOTES FEMALE PIPE THREAD
BFW DENOTES BEVELED FOR WELDING
GVD DENOTES GROOVED
FLG DENOTES FLANGE
PE DENOTES PLAIN END
- +UNIT WEIGHT DOES NOT INCLUDE ACCESSORIES (SEE ACCESSORY DRAWINGS)
- MAKE-UP WATER PRESSURE
20 psi MIN [137 kPa], 50 psi MAX [344 kPa]
- *-APPROXIMATE DIMENSIONS DO NOT USE FOR PRE-FABRICATION OF CONNECTING PIPING
- 3/4" [19mm] DIA. MOUNTING HOLES. REFER TO RECOMMENDED STEEL SUPPORT DRAWING.
- DIMENSIONS LISTED AS FOLLOWS:
ENGLISH FT-IN
METRIC [mm]

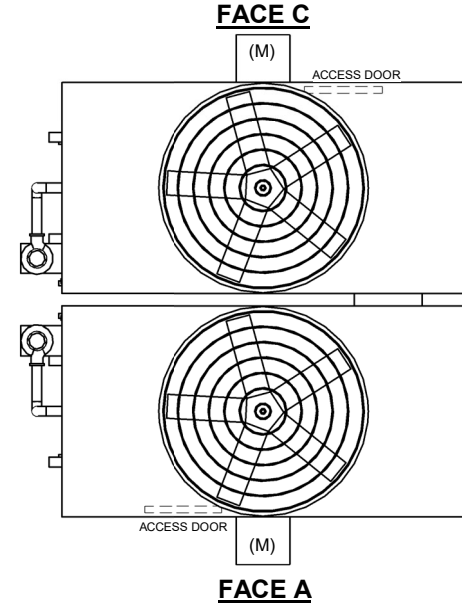

**FACE B
PLAN VIEW**

FACE D

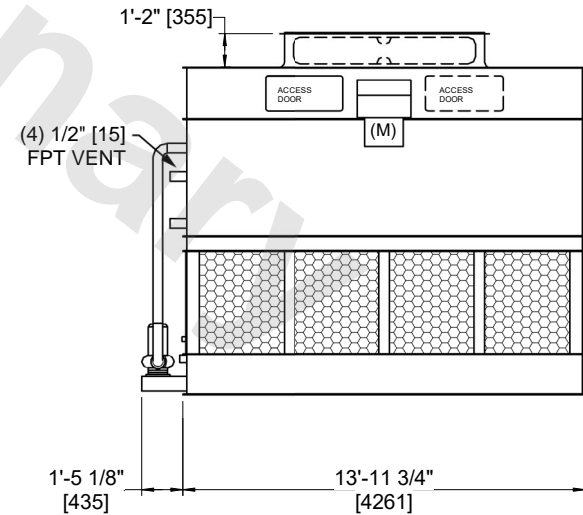
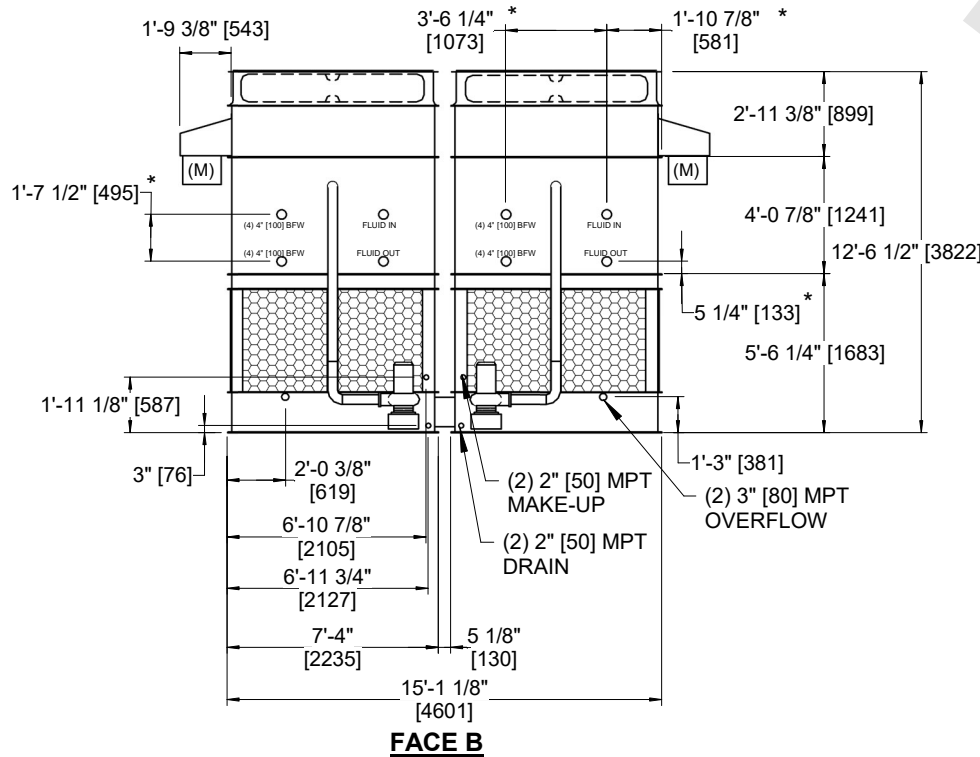

FACE A

SHIPPING WEIGHT	21140 lbs+ [9590] kg+	OPERATING WEIGHT	29140 lbs+ [13220] kg+	HEAVIEST SECTION WEIGHT	8380 lbs+ [3805] kg+	NO. OF SHIPPING SECTIONS	4	DRAWN BY:	JLG
-----------------	-----------------------	------------------	------------------------	-------------------------	----------------------	--------------------------	---	-----------	-----