

EVAPCO, INC.



| | | | | | | |
|-------------------------------|-------------------------------------|-----------------|----------------------------|-----------|------------------|----------|
| UNIT CLOSED CIRCUIT COOLER | MODEL # eco-ATWB-H 10-3K36-Z-U34 | SCALE N.T.S. | DWG. # EGHTM36MR-DRB-SF | REV. - | DATE 4/5/2026 | SERIAL # |
|-------------------------------|-------------------------------------|-----------------|----------------------------|-----------|------------------|----------|

NOTES:

1. (M)- FAN MOTOR LOCATION
2. HEAVIEST SECTION IS COIL SECTION
3. MPT DENOTES MALE PIPE THREAD
FPT DENOTES FEMALE PIPE THREAD
BFW DENOTES BEVELED FOR WELDING
4. +UNIT WEIGHT DOES NOT INCLUDE ACCESSORIES (SEE ACCESSORY DRAWINGS)
5. MAKE-UP WATER PRESSURE
20 psi MIN [137 kPa], 50 psi MAX [344 kPa]

6. DIMENSIONS LISTED AS FOLLOWS:
ENGLISH IN
[METRIC] [mm]
7. * - APPROXIMATE DIMENSIONS DO NOT USE FOR PRE-FABRICATION OF CONNECTING PIPING.

**FACE 2
PLAN VIEW**

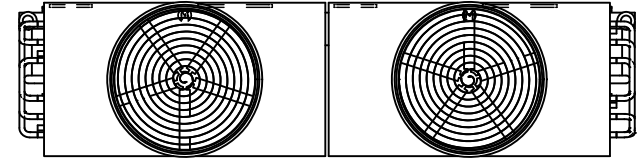

FACE 1

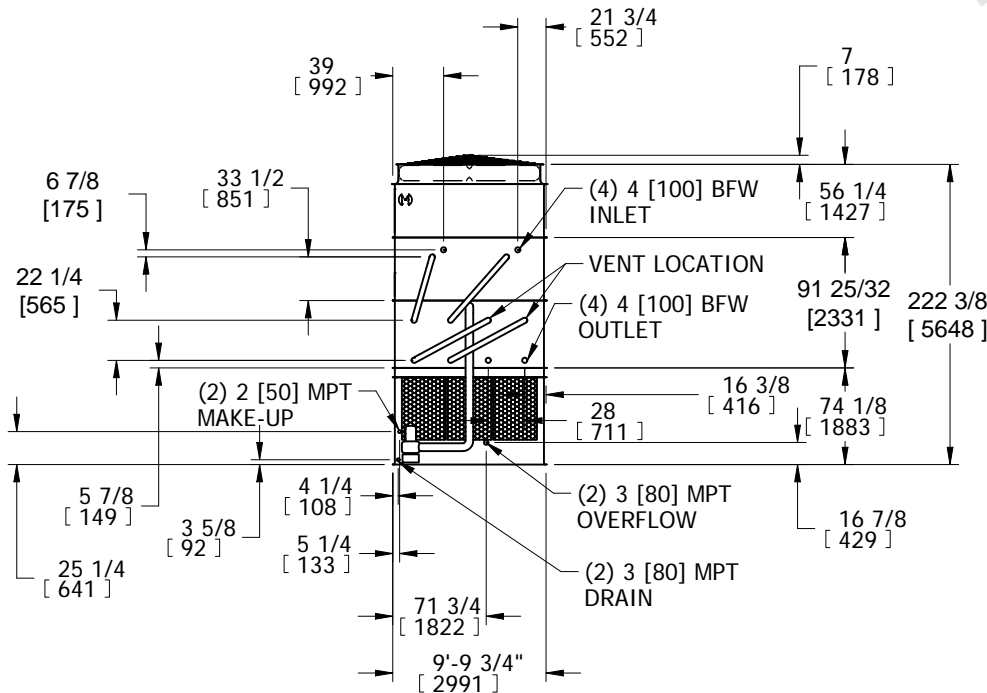

FACE 2

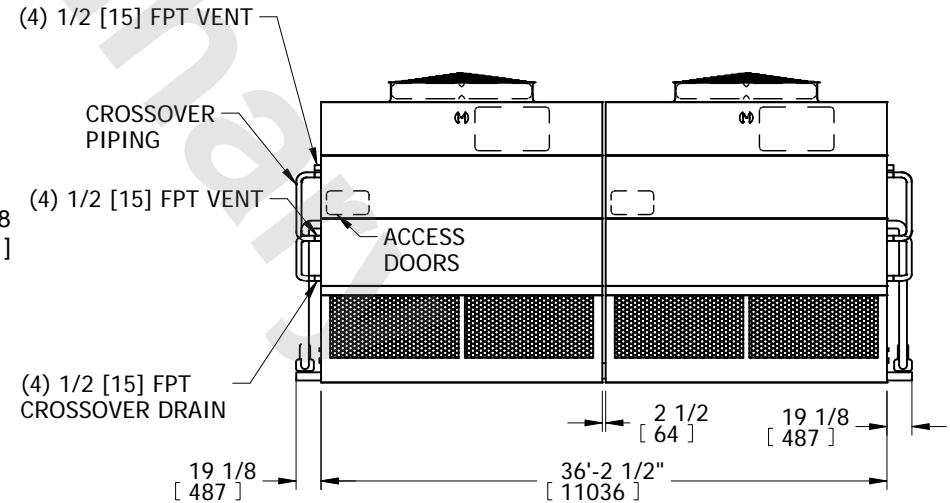

FACE 1

| | | | | |
|---|--|--|-------------------------------|------------------|
| SHIPPING WEIGHT 57070 lbs+ [25890] kg+ | OPERATING WEIGHT 76910 lbs+ [34890] kg+ | HEAVIEST SECTION WEIGHT 20410 lbs+ [9255] kg+ | NO. OF SHIPPING SECTIONS 6 | DRAWN BY: SFR |
|---|--|--|-------------------------------|------------------|