

# EVAPCO, INC.



|      |                       |         |                        |       |        |        |                  |      |   |      |           |          |  |
|------|-----------------------|---------|------------------------|-------|--------|--------|------------------|------|---|------|-----------|----------|--|
| UNIT | CLOSED CIRCUIT COOLER | MODEL # | eco-ATWB-H 12-3M28-U22 | SCALE | N.T.S. | DWG. # | EGH1228MR-DRC-ST | REV. | - | DATE | 6/23/2026 | SERIAL # |  |
|------|-----------------------|---------|------------------------|-------|--------|--------|------------------|------|---|------|-----------|----------|--|

- NOTES:
- (M)- FAN MOTOR LOCATION
  - HEAVIEST SECTION IS COIL SECTION
  - MPT DENOTES MALE PIPE THREAD  
FPT DENOTES FEMALE PIPE THREAD  
BFW DENOTES BEVELED FOR WELDING  
GVD DENOTES GROOVED  
FLG DENOTES FLANGE
  - +UNIT WEIGHT DOES NOT INCLUDE ACCESSORIES (SEE ACCESSORY DRAWINGS)
  - MAKE-UP WATER PRESSURE  
20 psi MIN [137 kPa], 50 psi MAX [344 kPa]

- 3/4" [19mm] DIA. MOUNTING HOLES. REFER TO RECOMMENDED STEEL SUPPORT DRAWING.
- \* - APPROXIMATE DIMENSIONS DO NOT USE FOR PRE-FABRICATION OF CONNECTING PIPING.

**FACE 2  
PLAN VIEW**



**FACE 1**

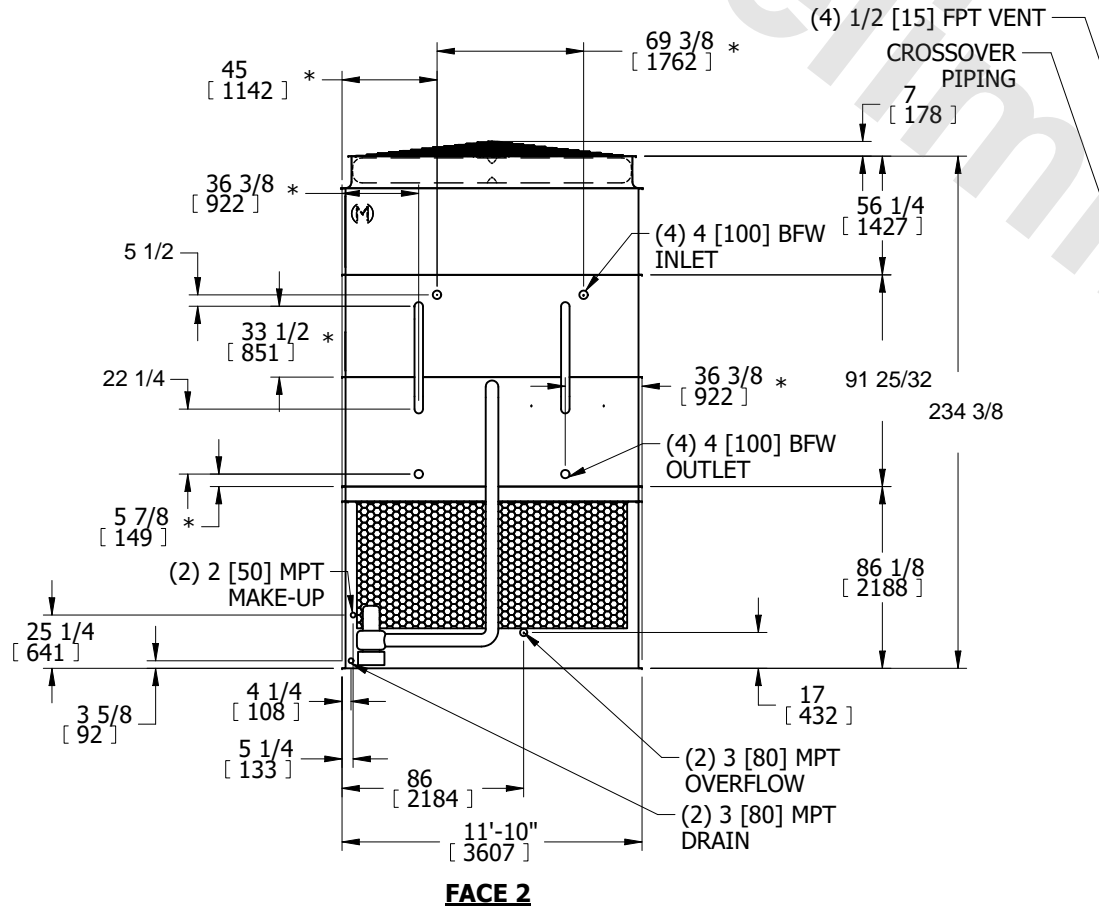

**FACE 2**



**FACE 1**

|                 |                        |                  |                        |                         |                       |                          |   |           |     |
|-----------------|------------------------|------------------|------------------------|-------------------------|-----------------------|--------------------------|---|-----------|-----|
| SHIPPING WEIGHT | 48080 lbs+ [21810] kg+ | OPERATING WEIGHT | 68200 lbs+ [30935] kg+ | HEAVIEST SECTION WEIGHT | 17780 lbs+ [8065] kg+ | NO. OF SHIPPING SECTIONS | 6 | DRAWN BY: | SFR |
|-----------------|------------------------|------------------|------------------------|-------------------------|-----------------------|--------------------------|---|-----------|-----|