

EVAPCO, INC.



| | | | | | | |
|-------------------------------|-------------------------------------|-----------------|----------------------------|-----------|------------------|----------|
| UNIT CLOSED CIRCUIT COOLER | MODEL # eco-ATWB-H 24-4L14-Z-U22 | SCALE N.T.S. | DWG. # EGH2414MR-DRE-SF | REV. - | DATE 4/4/2026 | SERIAL # |
|-------------------------------|-------------------------------------|-----------------|----------------------------|-----------|------------------|----------|

- NOTES:
- (M)- FAN MOTOR LOCATION
 - HEAVIEST SECTION IS COIL SECTION
 - MPT DENOTES MALE PIPE THREAD
FPT DENOTES FEMALE PIPE THREAD
BFW DENOTES BEVELED FOR WELDING
GVD DENOTES GROOVED
FLG DENOTES FLANGE
 - +UNIT WEIGHT DOES NOT INCLUDE ACCESSORIES (SEE ACCESSORY DRAWINGS)
 - MAKE-UP WATER PRESSURE
20 psi MIN [137 kPa], 50 psi MAX [344 kPa]

- 3/4" [19mm] DIA. MOUNTING HOLES. REFER TO RECOMMENDED STEEL SUPPORT DRAWING.
- * - APPROXIMATE DIMENSIONS DO NOT USE FOR PRE-FABRICATION OF CONNECTING PIPING.

**FACE 2
PLAN VIEW**



FACE 1

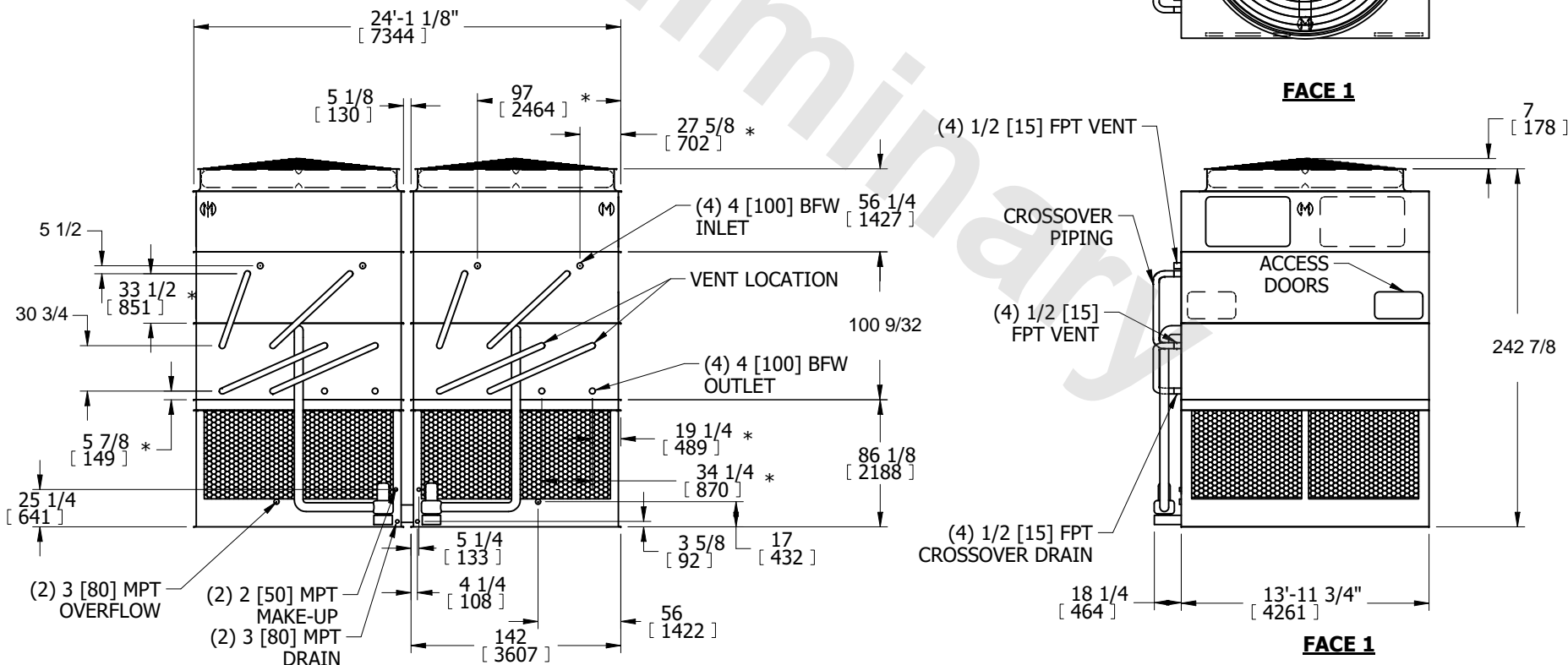

| | | | | |
|---|--|--|-------------------------------|------------------|
| SHIPPING WEIGHT 55420 lbs+ [25140] kg+ | OPERATING WEIGHT 77440 lbs+ [35130] kg+ | HEAVIEST SECTION WEIGHT 21500 lbs+ [9755] kg+ | NO. OF SHIPPING SECTIONS 6 | DRAWN BY: SFR |
|---|--|--|-------------------------------|------------------|