

EVAPCO, INC.



| | | | | | | |
|-------------------------------|-----------------------------------|-----------------|----------------------------|-----------|-------------------|----------|
| UNIT CLOSED CIRCUIT COOLER | MODEL # eco-ATWB-H 24-1M20-U22 | SCALE N.T.S. | DWG. # EGH242002-DRD-ST | REV. - | DATE 6/20/2026 | SERIAL # |
|-------------------------------|-----------------------------------|-----------------|----------------------------|-----------|-------------------|----------|

- NOTES:
- (M)- FAN MOTOR LOCATION
 - HEAVIEST SECTION IS COIL SECTION
 - MPT DENOTES MALE PIPE THREAD
FPT DENOTES FEMALE PIPE THREAD
BFW DENOTES BEVELED FOR WELDING
 - +UNIT WEIGHT DOES NOT INCLUDE ACCESSORIES (SEE ACCESSORY DRAWINGS)
 - MAKE-UP WATER PRESSURE
20 psi MIN [137 kPa], 50 psi MAX [344 kPa]

- DIMENSIONS LISTED AS FOLLOWS:
ENGLISH IN
[METRIC] [mm]
- * - APPROXIMATE DIMENSIONS DO NOT USE FOR PRE-FABRICATION OF CONNECTING PIPING.

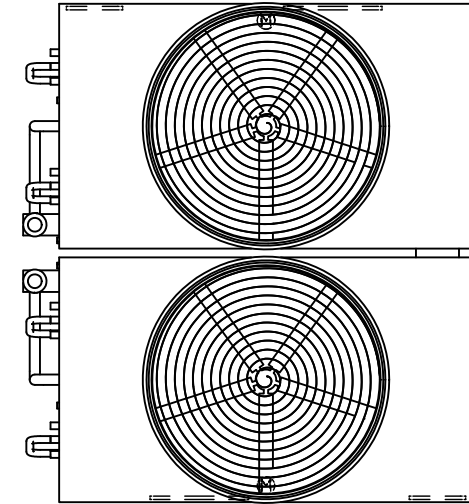

**FACE 2
PLAN VIEW**

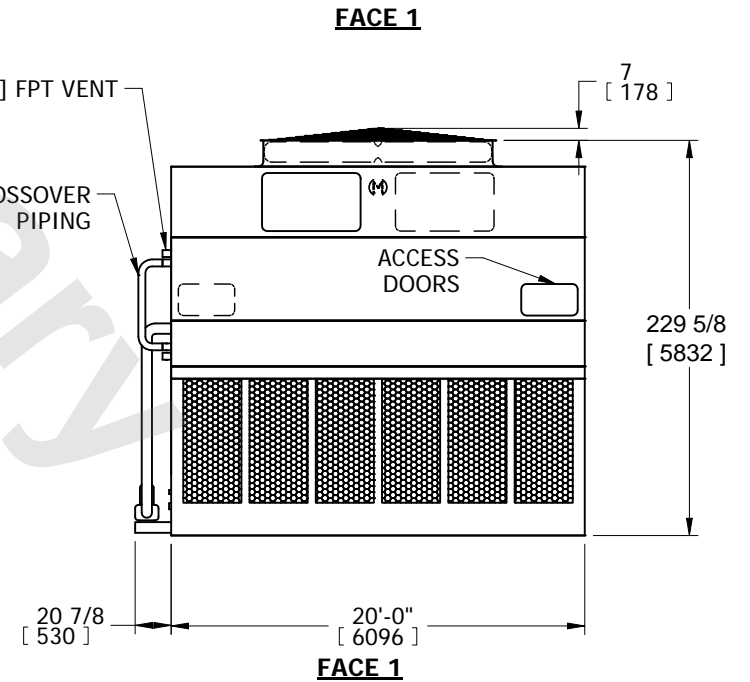
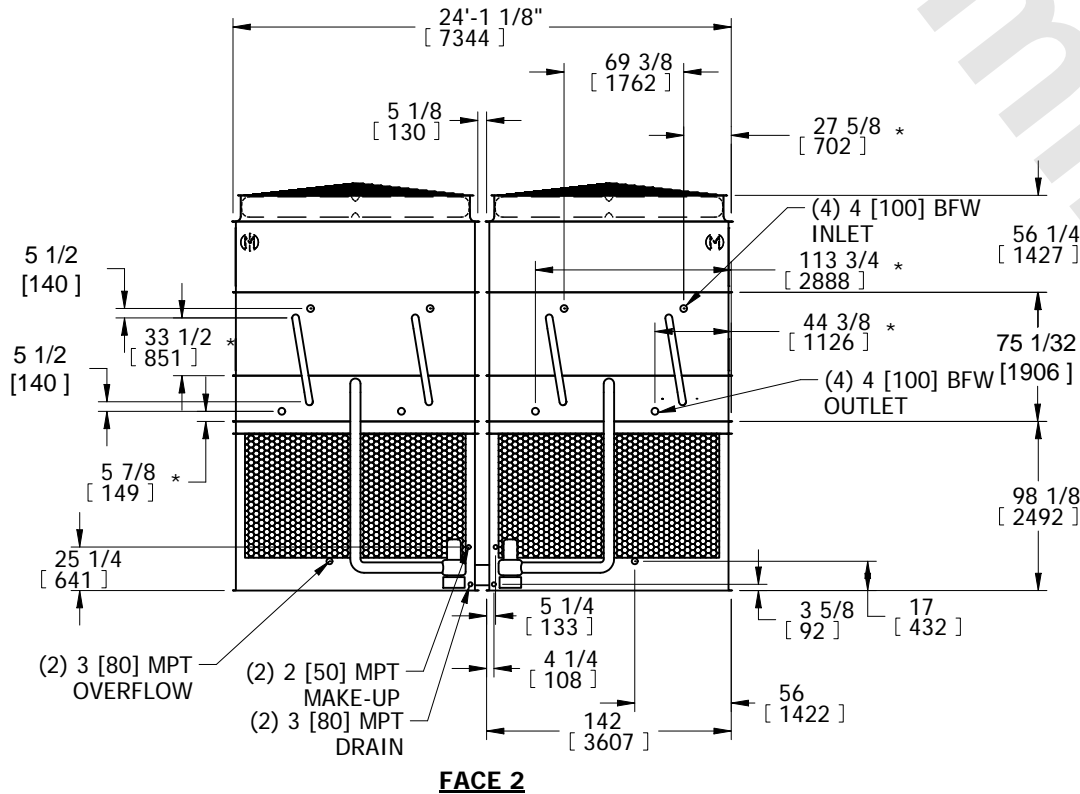

| | | | | |
|---|--|--|-------------------------------|------------------|
| SHIPPING WEIGHT 44710 lbs+ [20285] kg+ | OPERATING WEIGHT 67910 lbs+ [30805] kg+ | HEAVIEST SECTION WEIGHT 13920 lbs+ [6315] kg+ | NO. OF SHIPPING SECTIONS 6 | DRAWN BY: SFR |
|---|--|--|-------------------------------|------------------|