

# EVAPCO, INC.



|                               |                                   |                 |                            |           |                  |          |
|-------------------------------|-----------------------------------|-----------------|----------------------------|-----------|------------------|----------|
| UNIT<br>CLOSED CIRCUIT COOLER | MODEL #<br>eco-ATWB-H 17-1L12-U12 | SCALE<br>N.T.S. | DWG. #<br>EGH171202-DRD-ST | REV.<br>- | DATE<br>5/1/2026 | SERIAL # |
|-------------------------------|-----------------------------------|-----------------|----------------------------|-----------|------------------|----------|

- NOTES:
- (M)- FAN MOTOR LOCATION
  - HEAVIEST SECTION IS COIL SECTION
  - MPT DENOTES MALE PIPE THREAD  
FPT DENOTES FEMALE PIPE THREAD  
BFW DENOTES BEVELED FOR WELDING
  - +UNIT WEIGHT DOES NOT INCLUDE ACCESSORIES (SEE ACCESSORY DRAWINGS)
  - MAKE-UP WATER PRESSURE  
20 psi MIN [137 kPa], 50 psi MAX [344 kPa]

- DIMENSIONS LISTED AS FOLLOWS:  
ENGLISH IN  
[METRIC] [mm]
- \* - APPROXIMATE DIMENSIONS DO NOT USE FOR PRE-FABRICATION OF CONNECTING PIPING.

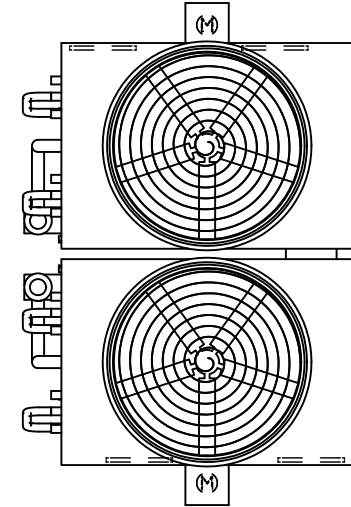

**FACE 2  
PLAN VIEW**

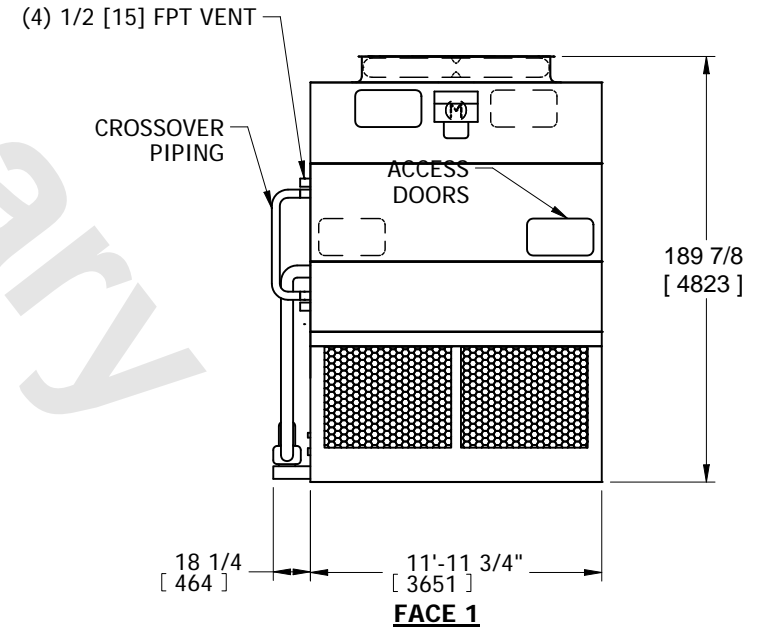
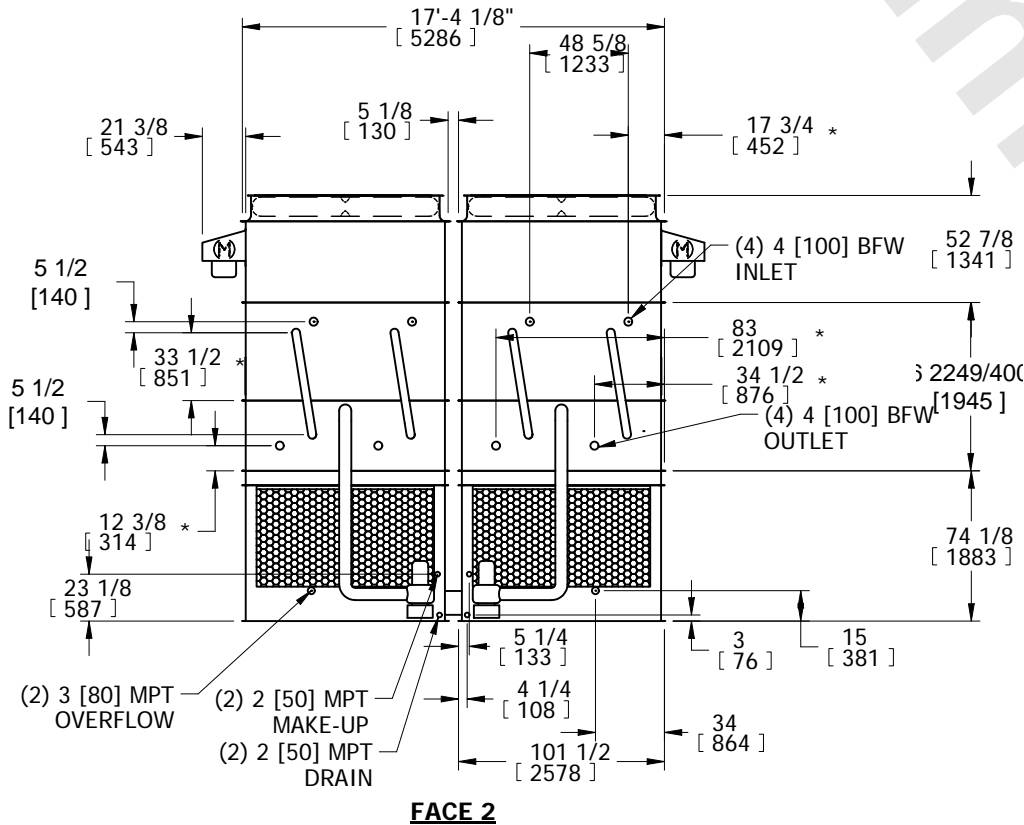

|  |  |   |                               |                  |
|--|--|---|-------------------------------|------------------|
| SHIPPING WEIGHT<br>19830 lbs+ [8995] kg+ | OPERATING WEIGHT<br>28170 lbs+ [12780] kg+ | HEAVIEST SECTION WEIGHT<br>5540 lbs+ [2510] kg+ | NO. OF SHIPPING SECTIONS<br>6 | DRAWN BY:<br>SFR |
|--|--|---|-------------------------------|------------------|