

# EVAPCO, INC.



|                               |                                    |                |                            |           |                   |          |
|-------------------------------|------------------------------------|----------------|----------------------------|-----------|-------------------|----------|
| UNIT<br>CLOSED CIRCUIT COOLER | MODEL #<br>eco-ATWB-H 9-2K14-Z-U34 | SCALE<br>N.T.S | DWG. #<br>EGH0914MR-DRC-SF | REV.<br>- | DATE<br>3/13/2026 | SERIAL # |
|-------------------------------|------------------------------------|----------------|----------------------------|-----------|-------------------|----------|

- NOTES:
- (M)- FAN MOTOR LOCATION
  - HEAVIEST SECTION IS COIL SECTION
  - MPT DENOTES MALE PIPE THREAD  
FPT DENOTES FEMALE PIPE THREAD  
BFW DENOTES BEVELED FOR WELDING
  - +UNIT WEIGHT DOES NOT INCLUDE ACCESSORIES (SEE ACCESSORY DRAWINGS)
  - MAKE-UP WATER PRESSURE  
20 psi MIN [137 kPa], 50 psi MAX [344 kPa]

- DIMENSIONS LISTED AS FOLLOWS:  
ENGLISH IN  
[METRIC] [mm]
- \* - APPROXIMATE DIMENSIONS DO NOT USE FOR PRE-FABRICATION OF CONNECTING PIPING.

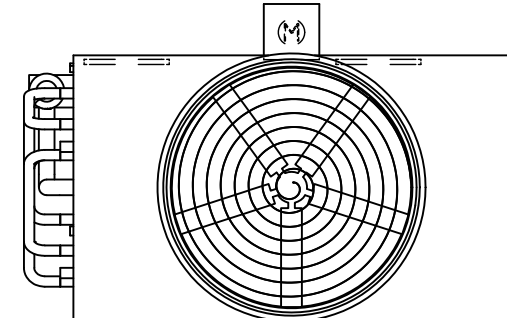

**FACE 2  
PLAN VIEW**

**FACE 1**

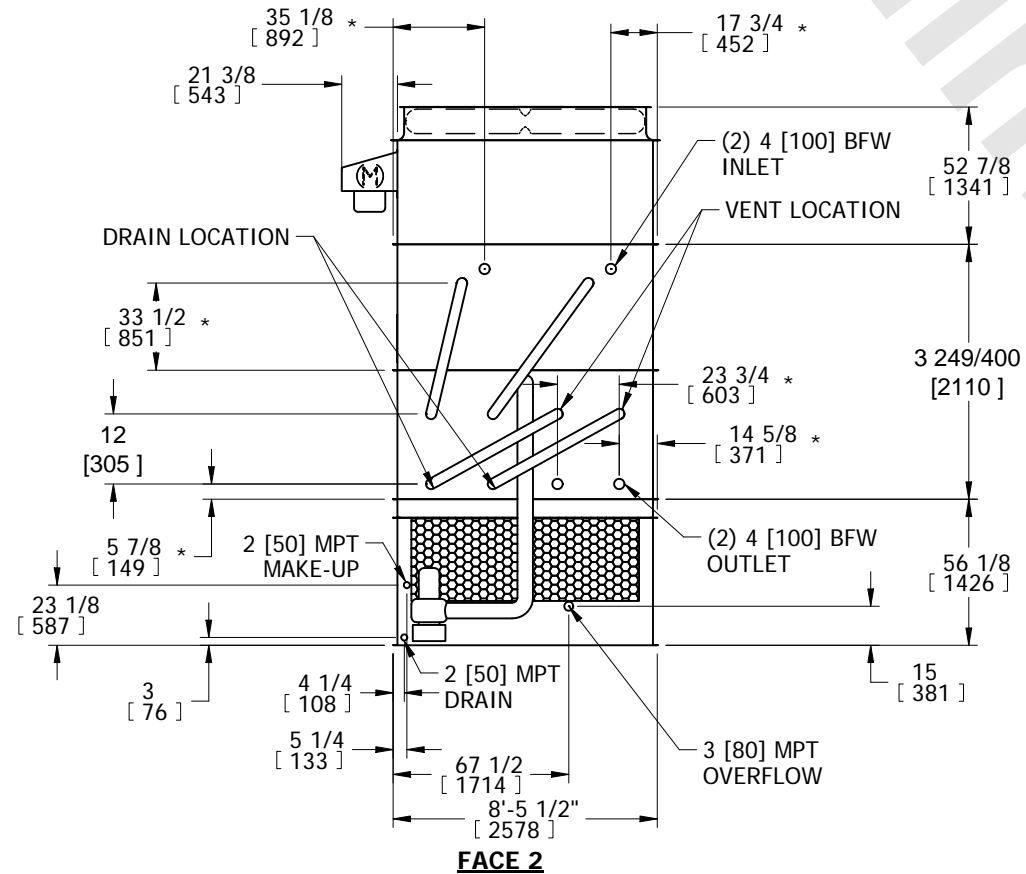

**FACE 2**

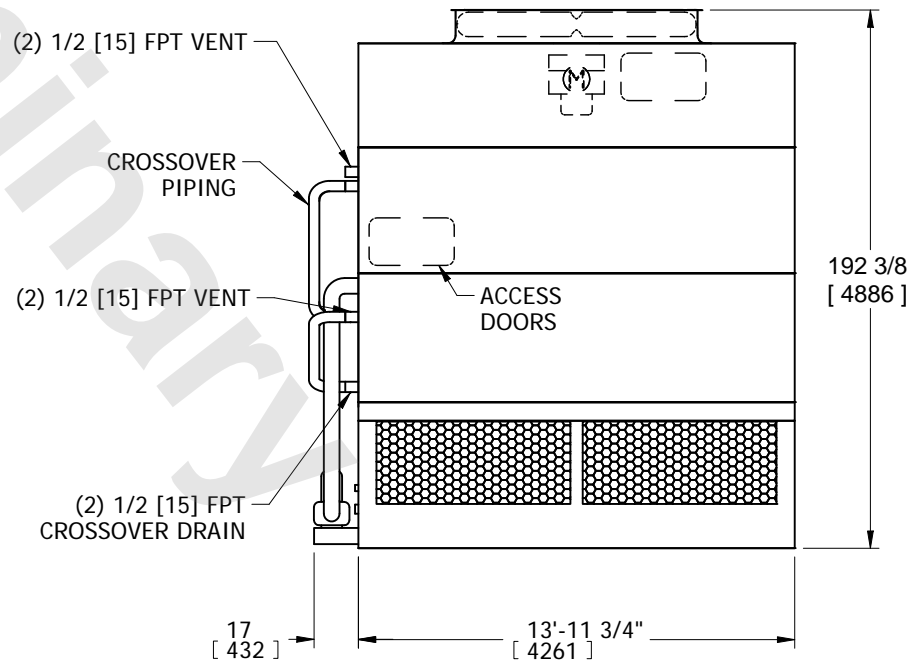

**FACE 1**

|  |   |  |                               |                  |
|--|---|--|-------------------------------|------------------|
| SHIPPING WEIGHT<br>15240 lbs+ [6915] kg+ | OPERATING WEIGHT<br>21020 lbs+ [9535] kg+ | HEAVIEST SECTION WEIGHT<br>10550 lbs+ [4785] kg+ | NO. OF SHIPPING SECTIONS<br>3 | DRAWN BY:<br>SFR |
|--|---|--|-------------------------------|------------------|