

# EVAPCO, INC.



|      |                       |         |                         |       |       |        |                  |      |   |      |          |          |  |
|------|-----------------------|---------|-------------------------|-------|-------|--------|------------------|------|---|------|----------|----------|--|
| UNIT | CLOSED CIRCUIT COOLER | MODEL # | eco-ATWB-H 9-4K12-Z-U12 | SCALE | N.T.S | DWG. # | EGH0912MR-DRC-SF | REV. | - | DATE | 4/5/2026 | SERIAL # |  |
|------|-----------------------|---------|-------------------------|-------|-------|--------|------------------|------|---|------|----------|----------|--|

- NOTES:
- (M)- FAN MOTOR LOCATION
  - HEAVIEST SECTION IS COIL SECTION
  - MPT DENOTES MALE PIPE THREAD  
FPT DENOTES FEMALE PIPE THREAD  
BFW DENOTES BEVELED FOR WELDING
  - +UNIT WEIGHT DOES NOT INCLUDE ACCESSORIES (SEE ACCESSORY DRAWINGS)
  - MAKE-UP WATER PRESSURE  
20 psi MIN [137 kPa], 50 psi MAX [344 kPa]

6. DIMENSIONS LISTED AS FOLLOWS:  
ENGLISH IN  
[METRIC] [mm]
7. \* - APPROXIMATE DIMENSIONS DO NOT USE FOR PRE-FABRICATION OF CONNECTING PIPING.



**FACE 2  
PLAN VIEW**

**FACE 1**

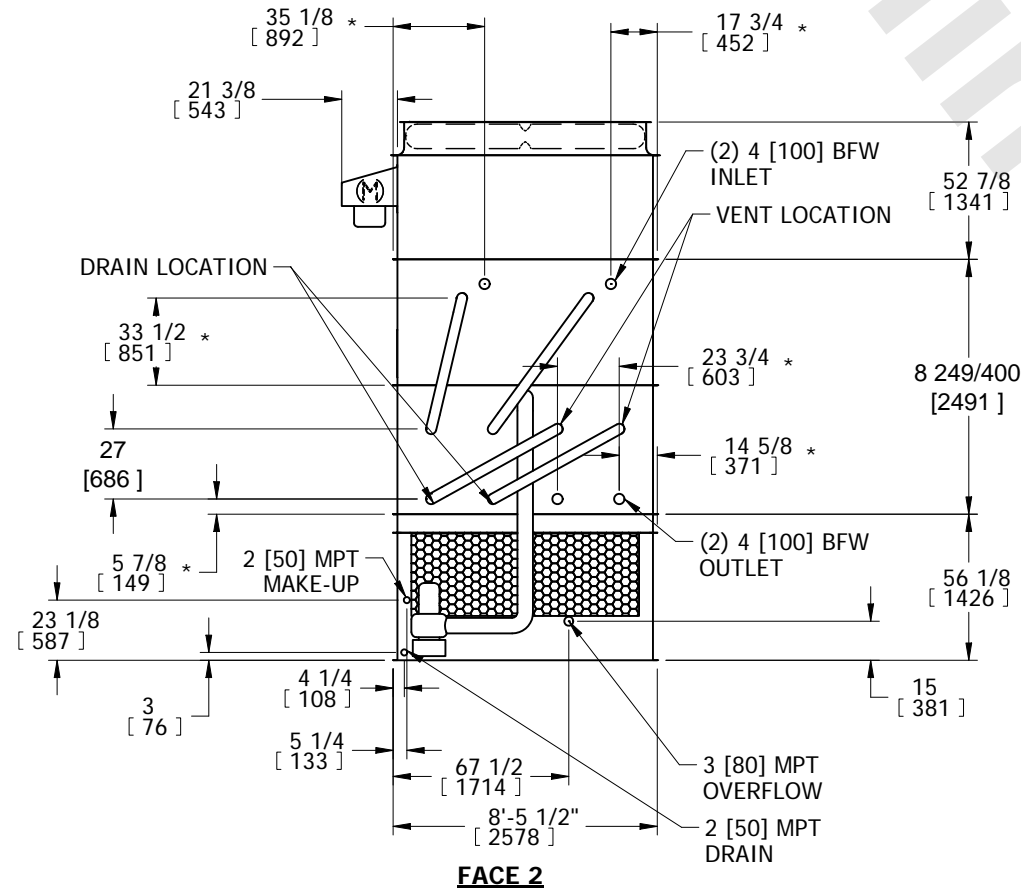

**FACE 2**

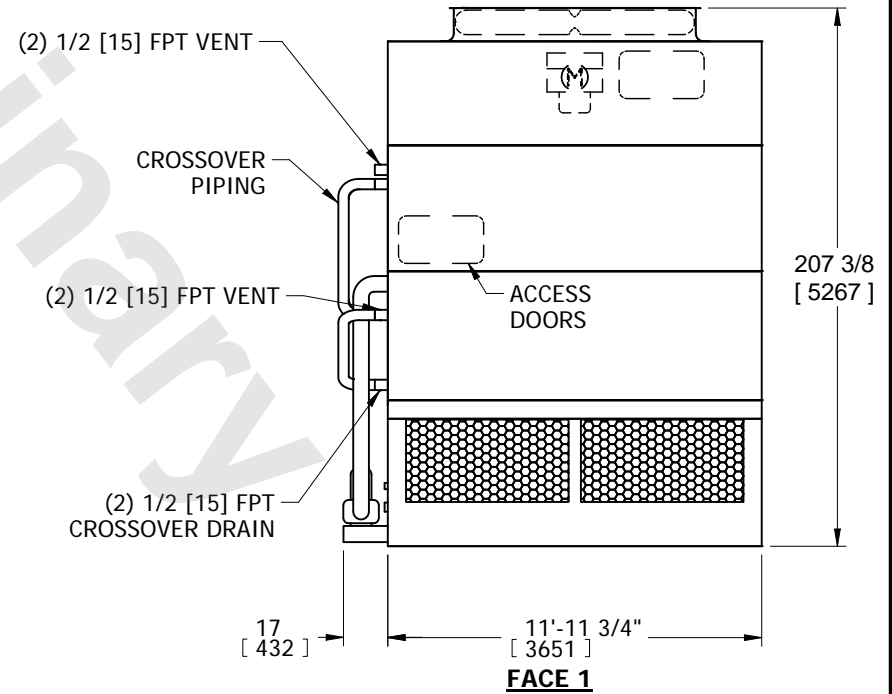

**FACE 1**

|                 |                       |                  |                        |                         |                       |                          |   |           |     |
|-----------------|-----------------------|------------------|------------------------|-------------------------|-----------------------|--------------------------|---|-----------|-----|
| SHIPPING WEIGHT | 16660 lbs+ [7560] kg+ | OPERATING WEIGHT | 22510 lbs+ [10215] kg+ | HEAVIEST SECTION WEIGHT | 12320 lbs+ [5585] kg+ | NO. OF SHIPPING SECTIONS | 3 | DRAWN BY: | SFR |
|-----------------|-----------------------|------------------|------------------------|-------------------------|-----------------------|--------------------------|---|-----------|-----|