

| | |
|---------|---------------|
| UNIT | COOLING TOWER |
| MODEL # | LPT-526 |
| SCALE | NTS |

EVAPCO, INC.



| | | | |
|----------|-----------------|------|----------|
| DWG. # | TV05061P-DRE-ST | REV. | - |
| SERIAL # | | DATE | 7/3/2026 |

- NOTES:
- (M) FAN MOTOR LOCATION
 - MPT DENOTES MALE PIPE THREAD
FPT DENOTES FEMALE PIPE THREAD
BFW DENOTES BEVELED FOR WELDING
GVD DENOTES GROOVED
FLG DENOTES FLANGE
 - + UNIT WEIGHT DOES NOT INCLUDE ACCESSORIES (SEE SEPARATE DRAWINGS FOR ACCESSORIES)
 - 3/4" DIA. MOUNTING HOLES. REFER TO RECOMMENDED STEEL SUPPORT DRAWING
 - MAKE-UP WATER PRESSURE-20 psi MIN, 50 psi MAX
 - DIMENSIONS LISTED AS FOLLOWS:
ENGLISH FT-IN
[METRIC] MM

FACE B
PLAN VIEW

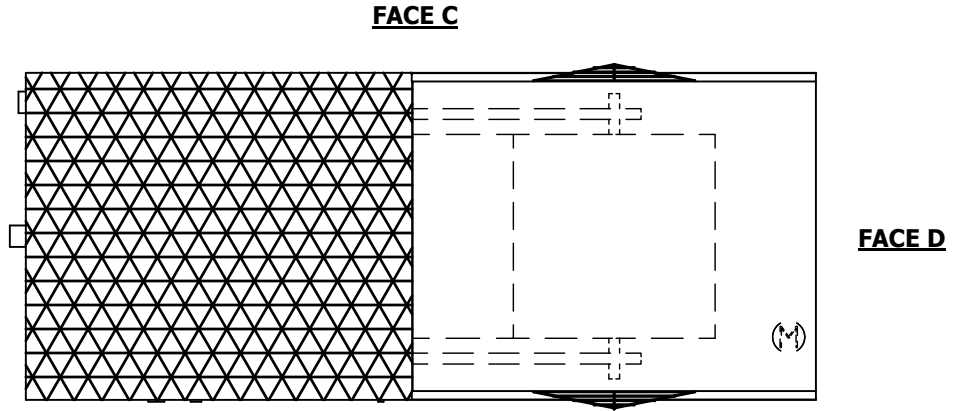

FACE A

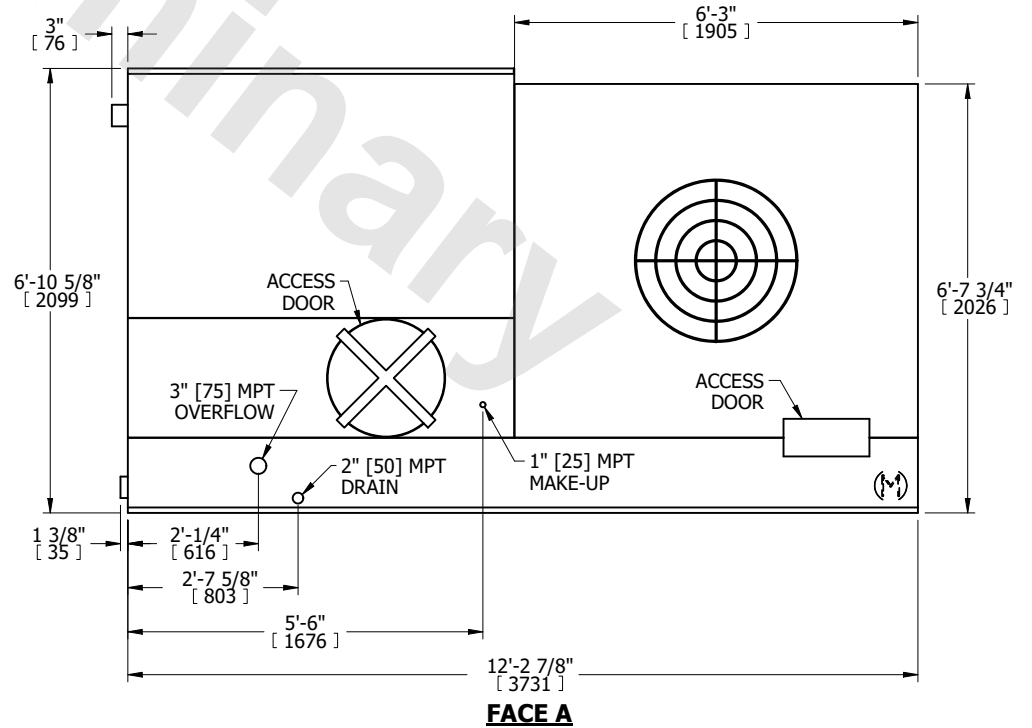
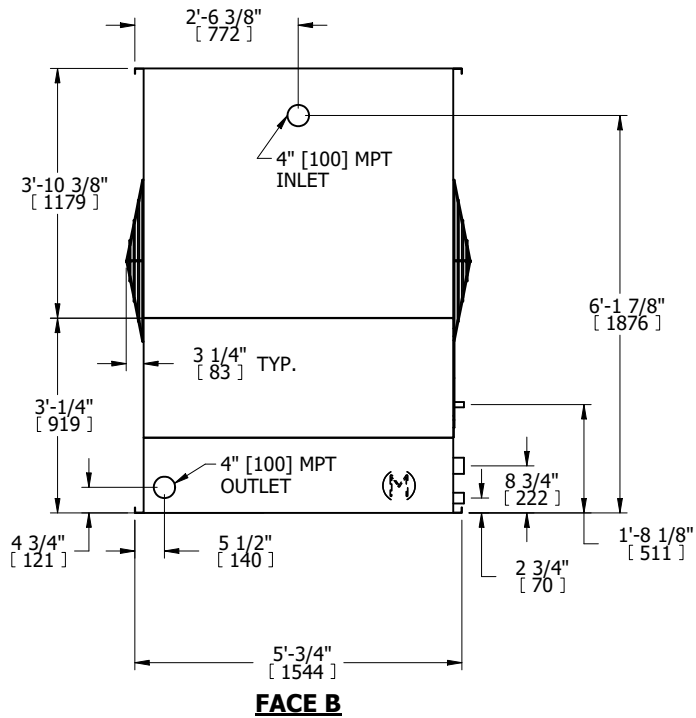

| | | | | | | | | | |
|-----------------|----------------------|------------------|----------------------|-------------------------|----------------------|--------------------------|---|-----------|-----|
| SHIPPING WEIGHT | 2330 lbs+ [1060] kg+ | OPERATING WEIGHT | 4050 lbs+ [1840] kg+ | HEAVIEST SECTION WEIGHT | 2330 lbs+ [1060] kg+ | NO. OF SHIPPING SECTIONS | 1 | DRAWN BY: | JLG |
|-----------------|----------------------|------------------|----------------------|-------------------------|----------------------|--------------------------|---|-----------|-----|