

| | | |
|---------|----------------------|-------|
| UNIT | COOLING TOWER | |
| MODEL # | AXS 12-16L22 | SCALE |

EVAPCO, INC.

| | | | |
|----------|-----------------|------|-----------|
| DWG. # | AX122213-DRA-ST | REV. | - |
| SERIAL # | | DATE | 6/25/2026 |

- NOTES:**
- (M)- FAN MOTOR LOCATION
 - HEAVIEST SECTION IS UPPER SECTION
 - MPT DENOTES MALE PIPE THREAD
FPT DENOTES FEMALE PIPE THREAD
BFW DENOTES BEVELED FOR WELDING
GVD DENOTES GROOVED
 - +UNIT WEIGHT DOES NOT INCLUDE ACCESSORIES (SEE ACCESSORY DRAWINGS)
 - MAKE-UP WATER PRESSURE
20 psi MIN [137 kPa], 50 psi MAX [344 kPa]
 - 3/4" DIA. MOUNTING HOLES. REFER TO RECOMMENDED STEEL SUPPORT DRAWING.
 - DIMENSIONS LISTED AS FOLLOWS: ENGLISH IN [METRIC] [mm]

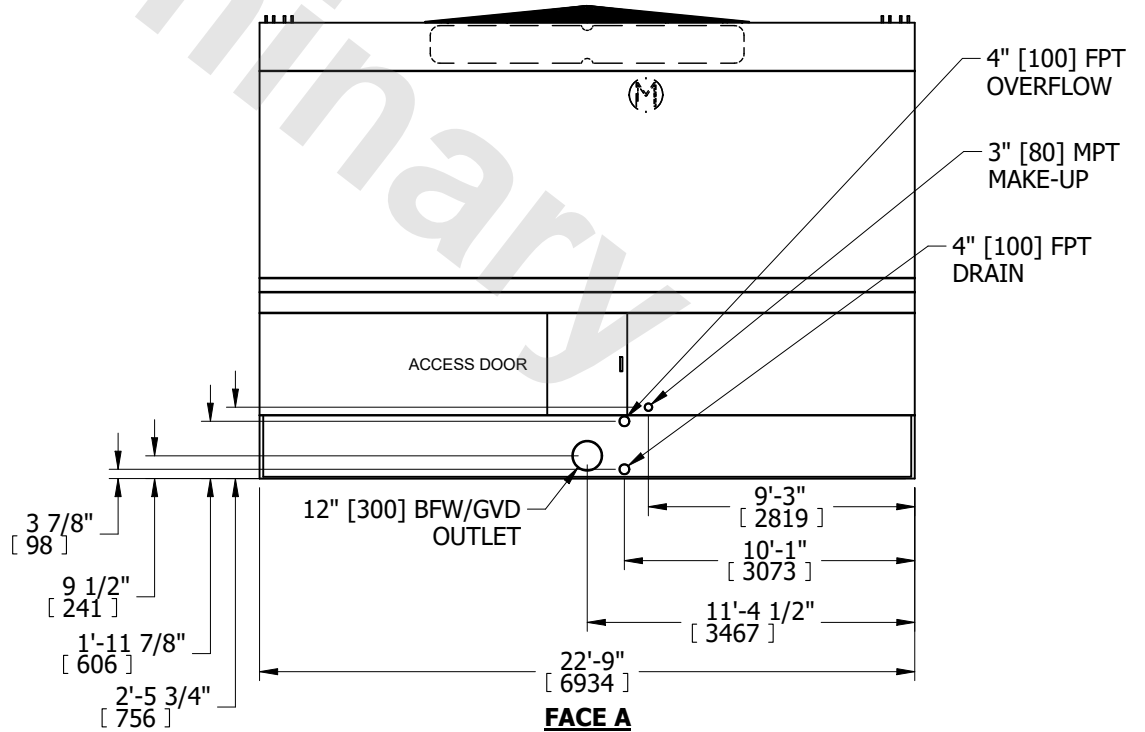
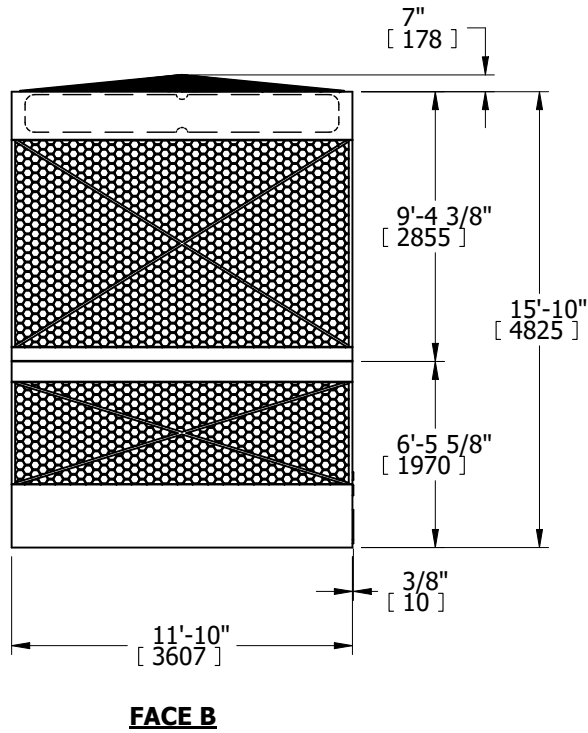
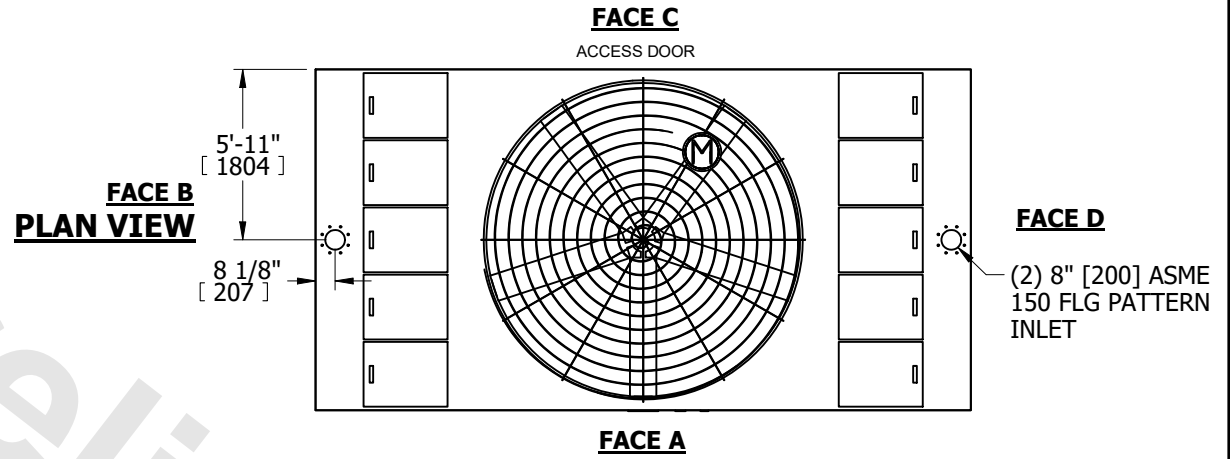

| | | | | | | | | | |
|-----------------|-----------------------|------------------|------------------------|-------------------------|----------------------|--------------------------|---|-----------|-----|
| SHIPPING WEIGHT | 15540 lbs+ [7050] kg+ | OPERATING WEIGHT | 36480 lbs+ [16550] kg+ | HEAVIEST SECTION WEIGHT | 9420 lbs+ [4275] kg+ | NO. OF SHIPPING SECTIONS | 2 | DRAWN BY: | JLM |
|-----------------|-----------------------|------------------|------------------------|-------------------------|----------------------|--------------------------|---|-----------|-----|