

UNIT	<b>COOLING TOWER</b>	
MODEL #	AXS 14-16N24	SCALE



DWG. #	AX142413-DRA-ST	REV.	-
SERIAL #		DATE	6/25/2026

- NOTES:
1. (M)- FAN MOTOR LOCATION
  2. HEAVIEST SECTION IS UPPER SECTION
  3. MPT DENOTES MALE PIPE THREAD  
FPT DENOTES FEMALE PIPE THREAD  
BFW DENOTES BEVELED FOR WELDING  
GVD DENOTES GROOVED
  4. +UNIT WEIGHT DOES NOT INCLUDE ACCESSORIES (SEE ACCESSORY DRAWINGS)
  5. MAKE-UP WATER PRESSURE  
20 psi MIN [137 kPa], 50 psi MAX [344 kPa]
  6. 3/4" DIA. MOUNTING HOLES. REFER TO RECOMMENDED STEEL SUPPORT DRAWING.
  7. DIMENSIONS LISTED AS FOLLOWS: ENGLISH IN [METRIC] [mm]

**FACE B  
PLAN VIEW**



**FACE D**  
(2) 10" [250] ASME 150 BOLT PATTERN INLET

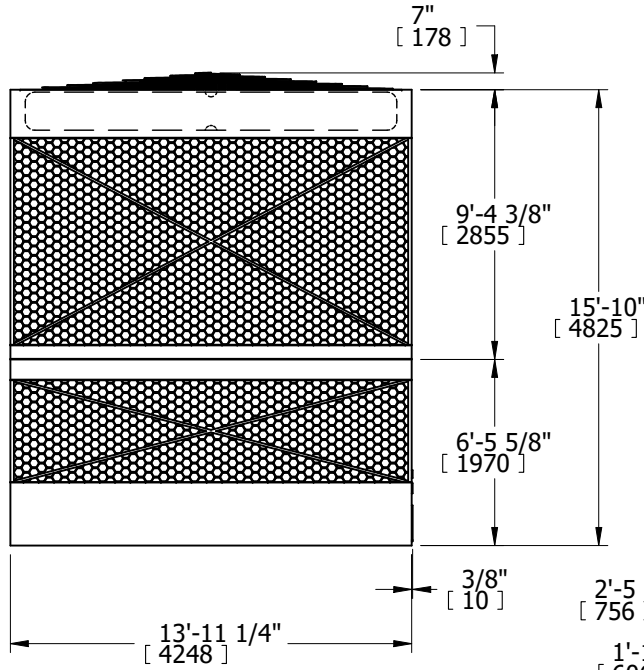

**FACE B**

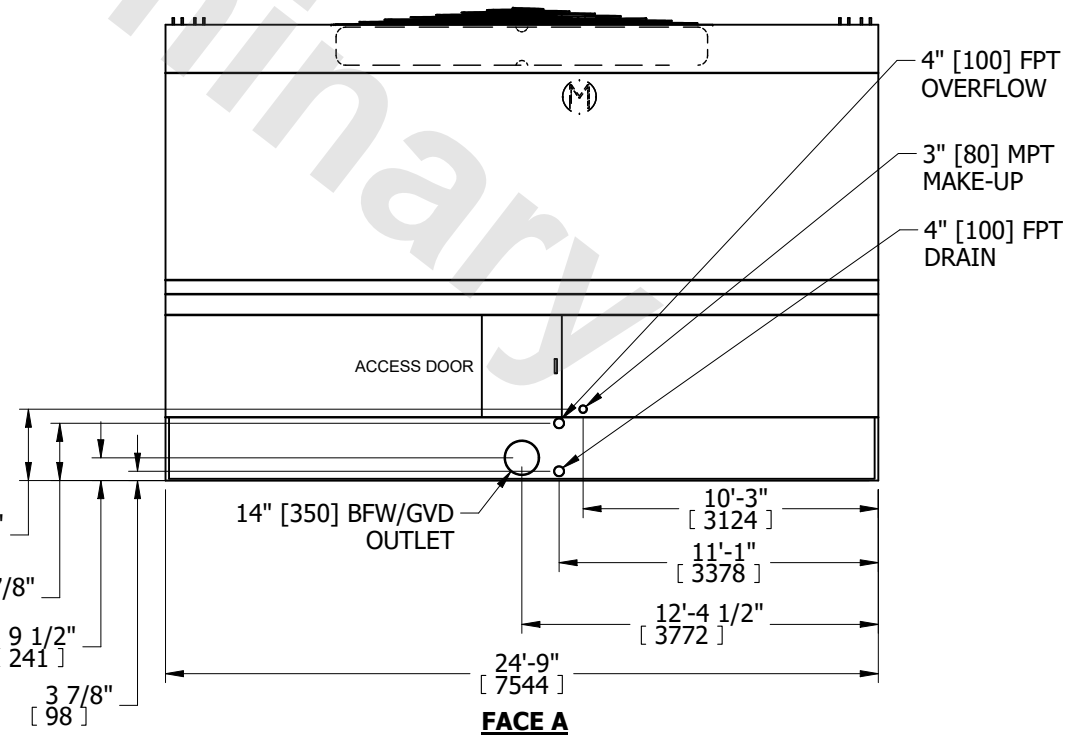

**FACE A**

4" [100] FPT OVERFLOW  
3" [80] MPT MAKE-UP  
4" [100] FPT DRAIN

SHIPPING WEIGHT	20210 lbs+ [9170] kg+	OPERATING WEIGHT	46860 lbs+ [21260] kg+	HEAVIEST SECTION WEIGHT	12110 lbs+ [5495] kg+	NO. OF SHIPPING SECTIONS	2	DRAWN BY:	AWT
-----------------	-----------------------	------------------	------------------------	-------------------------	-----------------------	--------------------------	---	-----------	-----