

# EVAPCO, INC.



|                                      |                     |       |                             |           |                   |          |
|--------------------------------------|---------------------|-------|-----------------------------|-----------|-------------------|----------|
| UNIT<br><b>EVAPORATIVE CONDENSER</b> | MODEL #<br>PHC-L463 | SCALE | DWG. #<br>HCS1224S06-DRC-ST | REV.<br>- | DATE<br>5/18/2026 | SERIAL # |
|--------------------------------------|---------------------|-------|-----------------------------|-----------|-------------------|----------|

**NOTES:**

1. (M)- FAN MOTOR LOCATION
2. HEAVIEST SECTION IS UPPER SECTION
3. MPT DENOTES MALE PIPE THREAD  
FPT DENOTES FEMALE PIPE THREAD  
BFW DENOTES BEVELED FOR WELDING  
GVD DENOTES GROOVED
4. +UNIT WEIGHT DOES NOT INCLUDE ACCESSORIES (SEE ACCESSORY DRAWINGS)
5. MAKE-UP WATER PRESSURE  
20 psi MIN [137 kPa], 50 psi MAX [344 kPa]
6. 3/4" DIA. MOUNTING HOLES. REFER TO RECOMMENDED STEEL SUPPORT DRAWING.
7. \*- APPROXIMATE DIMENSIONS DO NOT USE FOR PRE-FABRICATION OF CONNECTION PIPING.
8. \*\*-UNITS WITH 20HP PER FAN REQUIRE A TALLER FAN CYLINDER, ADD 5" TO THESE DIMENSIONS.
9. DIMENSIONS LISTED AS FOLLOWS: ENGLISH IN [METRIC] [mm]

**FACE 2  
PLAN VIEW**

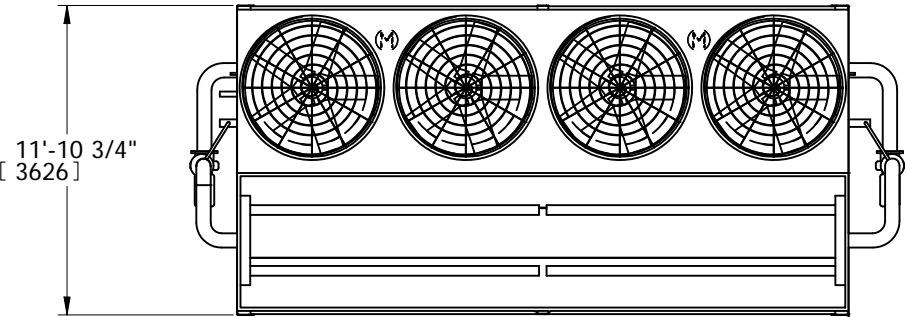

**FACE 1**

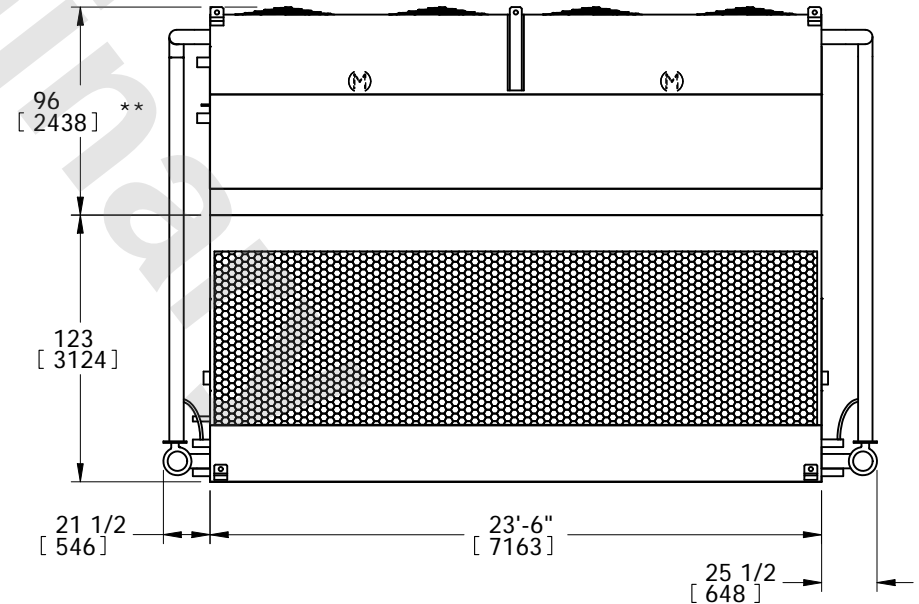
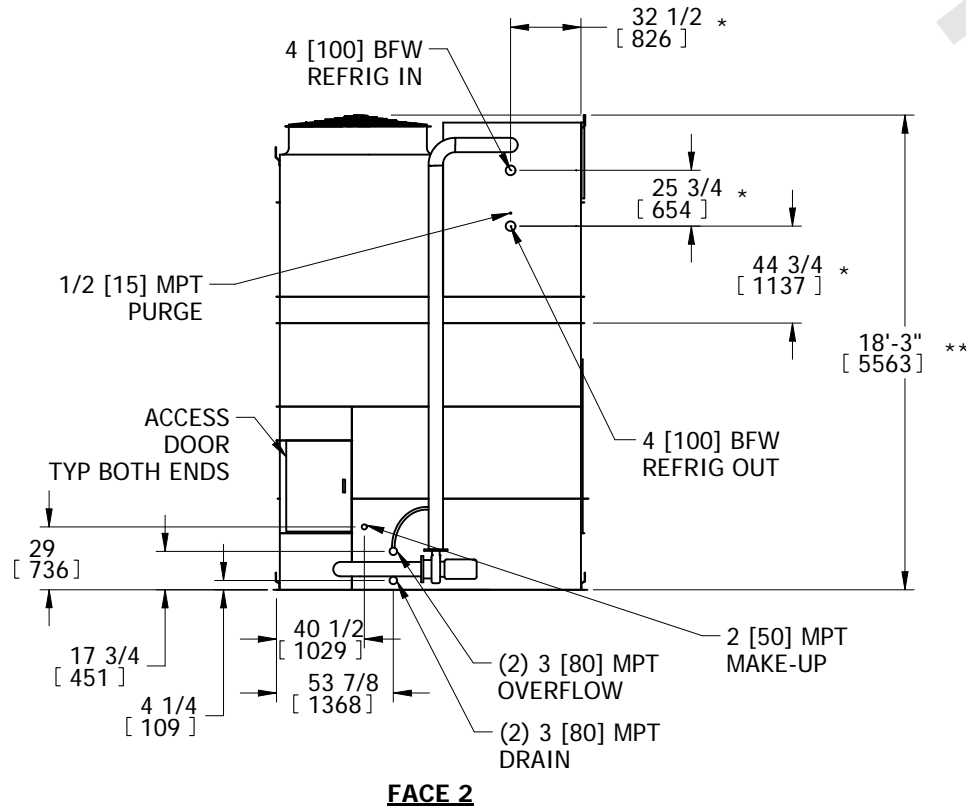

**FACE 1**

|  |  |  |                               |                  |
|--|--|--|-------------------------------|------------------|
| SHIPPING WEIGHT<br>22000 lbs+ [9980] kg+ | OPERATING WEIGHT<br>32620 lbs+ [14800] kg+ | HEAVIEST SECTION WEIGHT<br>13200 lbs+ [5990] kg+ | NO. OF SHIPPING SECTIONS<br>2 | DRAWN BY:<br>TLS |
|--|--|--|-------------------------------|------------------|