



# MONITORED RELEASE SYSTEM

## Installation, Operation & Maintenance Manual



EVAPCO...SPECIALISTS IN HEAT TRANSFER PRODUCTS  
AND INNOVATIVE TREATMENT SOLUTIONS



## Table of Contents

---

<b>1.0 Components and Function</b> .....	<b>2</b>
<b>2.0 MRF System Assembly</b> .....	<b>3</b>
<b>3.0 MRF System Installation</b> .....	<b>7</b>
3.1 General MRF System Installation Requirements .....	7
3.2 Open Tower Schematics .....	8
3.3 Remote Sump Schematics .....	9
<b>4.0 Conductivity Controller</b> .....	<b>10</b>
<b>5.0 MRF System Startup</b> .....	<b>10</b>
<b>6.0 Monitored Release Feeder (MRF)</b> .....	<b>11</b>
6.1 MRF Configuration .....	11
6.2 MRF Piping .....	11
6.3 Loading the MRF .....	12
6.4 Replenishment Chemistry .....	13
6.5 Periodic Testing .....	13
<b>7.0 Bio-Control Feeder BCF-NX</b> .....	<b>14</b>
7.1 BCF-NX Configuration .....	14
7.2 BCF-NX Piping .....	14
7.3 Loading the BCF-NX .....	14
7.4 Replenishment Chemistry .....	15
7.5 Periodic Testing .....	15
<b>8.0 Bio-Control Feeder BCF-OX</b> .....	<b>16</b>
8.1 Installation .....	16
8.2 Startup .....	17
8.3 BCF-OX Configuration .....	17
8.4 BCF-OX Piping .....	18
8.5 Loading the BCF-OX .....	18
8.6 Replenishment Chemistry .....	19
8.7 Periodic Testing .....	19
<b>9.0 Maintenance</b> .....	<b>19</b>
<b>10.0 Dry lay-up and Shutdown</b> .....	<b>20</b>
10.1 Dry lay-up .....	20
10.2 Shutdown .....	20
<b>11.0 Pre-cleaning and Passivation</b> .....	<b>20</b>
<b>12.0 Legionella</b> .....	<b>20</b>
<b>EVAPCO Standard Express Warranty for Smart Shield®</b> .....	<b>21</b>

## 1.0 Components and Function

---

- 1.1 EVAPCO's Smart Shield® for cooling tower and remote sump applications incorporates four separate components that work together to provide convenient and effective water treatment. These four components are:
  - 1.1.1 Conductivity Controller
  - 1.1.2 Monitored Release Feeder(s) (**MRF**)
  - 1.1.3 Bio-Control Feeder – Non-Oxidizer (**BCF-NX**)
  - 1.1.4 Bio-Control Feeder – Oxidizer (**BCF-OX**)
- 1.2 The conductivity controller maintains the recirculating water's cycles of concentration by continually measuring the conductivity of the recirculating water during system operation. When the recirculating water conductivity exceeds the programmed set point, the controller energizes a motorized ball-valve to bleed higher conductivity water from the system. Lower conductivity make-up water replaces bleed-off thereby reducing the conductivity of the system water. When the conductivity drops below the programmed differential, the controller closes the motorized ball-valve. This process maintains the conductivity of the system water within a defined band which helps to ensure water treatment success and water efficiency.
- 1.3 The Smart Shield® Monitored Release system utilizes solid scale and corrosion inhibitor chemistry which incorporates a tracer dye. During periods of wet operation, the inhibitor probe continually monitors the amount of the tracer dye that is present in the recirculating water. The probe sends an analog signal to the controller which is programmed with an algorithm designed to maintain precise control of the scale and corrosion inhibitor in the recirculating water system.
- 1.4 The Monitored Release Feeder(s) (**MRF**) is designed to provide safe and reliable feed of EVAPCO's MR (monitored release) scale and corrosion inhibitor chemistry. The **MRF** control valve is energized by the controller to add scale and corrosion inhibitor to the condenser water whenever the inhibitor residual falls below the programmed set point. To simplify replenishment, an inhibitor storage reservoir is included to hold any unused inhibitor chemistry that may remain in the **MRF** at the time of routine replenishment. Contact your EVAPCO Representative or Authorized Water Systems Service Provider for information on the appropriate type and amount of MR inhibitor chemistry required for your system.
- 1.5 A dual biocide treatment approach is utilized for cooling tower and remote sump applications. The biocide treatment may include **BCF-NX** feeder designed to hold and diffuse non-oxidizing biocides and/or **BCF-OX** feeder(s) designed to hold and diffuse oxidizing biocides. The specific biocide designed to be used in your system's **BCF** will be noted on a label attached to the placard next to the feeder. Contact your EVAPCO Representative or Authorized Water Systems Service Provider for information on the appropriate type and amount of biocide chemistry required for your system.
- 1.6 The **BCF-NX** feeder is designed to minimize microbiological populations over a 30-day period by releasing non-oxidizing biocide chemistry into the system on a timed sequence basis.
- 1.7 The **BCF-OX** feeder is designed to minimize microbiological populations over a 30-day period by releasing oxidizing biocide chemistry into the system. **BCF-OX** feeders are designed for semi-continuous timed biocide feed during periods of system operation. **BCF-OX** feeders require a dedicated return pipe from the feeder back to the low pressure side of the system pump or remote sump.
- 1.8 The **MRF**, **BCF-NX**, and **BCF-OX** are designed for operation with evaporative cooling towers and remote sump systems which have maximum system pressure of 125 psi (860 kPa) at 73 degrees Fahrenheit (23 degrees Celsius). The desired system pressure differential is 15 psi (100 kPa) to ensure consistent flow through the treatment system. If the operating pressure differential is less than 12 psi (80 kPa), or you have any questions, consult your EVAPCO Representative or Authorized Water Systems Service Provider. **DO NOT** use these Smart Shield® components on any other type of equipment without written authorization from EVAPCO.
- 1.9 Discharge water (blow down and overflow) from all chemically-treated cooling systems (including systems using EVAPCO Smart Shield®) must comply with local discharge regulations. This usually requires that the overflow and discharge from all treated evaporative systems be piped to the sanitary sewer. Check local sewer and discharge regulations before operating the cooling system with EVAPCO Smart Shield®.

## 2.0 MRF System Assembly

The EVAPCO Smart Shield® system for cooling tower and remote sump applications is designed for installation on the floor in a facility’s mechanical room. The Smart Shield® is provided in easy-to-assemble modules which are sized to fit through a standard doorway and are light enough to be moved by two people. All hardware necessary for system assembly is provided. The modules shall be assembled inside a mechanical room by the installing contractor (or by others) prior to evaporative cooling equipment commissioning.

- 2.1 Required tools: 1/2" (13 mm) nut driver -OR- slim 1/2" (13 mm) socket extension (<7/8" or 22 mm OD)  
 1/2" (13 mm) wrench -OR- socket  
 7/16" (10 mm) wrench -OR- socket  
 Thread sealant (Hercules Brush-on Blue Block™ or equivalent)  
 Metric thread sealant (Kolmat Fibre Seal or equivalent) Europe and Asia only
- 2.2 Before uncrating, assembly, and installation of the Smart Shield® system, consider the location of the recirculating water’s (2) supply and (2) return taps in the system piping headers. Each header tap should include an isolation valve at the header and be installed on the side of the pipe (see Figure 13). Consider sanitary drain location. Drain piping should provide for gravity flow. Also consider install location for both the **MRF** and **BCF-OX** systems, as motorized valves on the **BCF-OX** are field wired into the controller located on the **MRF** system. The **MRF** system may be located against a wall or in a corner of the mechanical room. Allow sufficient space for supply, return, and drain piping (minimum of 24" [610 mm]). Allow a minimum of 30" (760 mm) unobstructed space in front and to one side of the **MRF** system for routine servicing. Allow a minimum of 36" (915 mm) unobstructed space above feeders for routine servicing. See Figures 1 and 2.

Assembled Dimensions	LENGTH, in (mm)	WIDTH, in (mm)	HEIGHT, in (mm)
<b>MRF-1</b> System	84 (2135)	39-1/2 (1005)	60-1/2 (1540)
<b>MRF-2</b> System	106 (2695)	39-1/2 (1005)	60-1/2 (1540)

Figure 1 – MRF System Dimensions

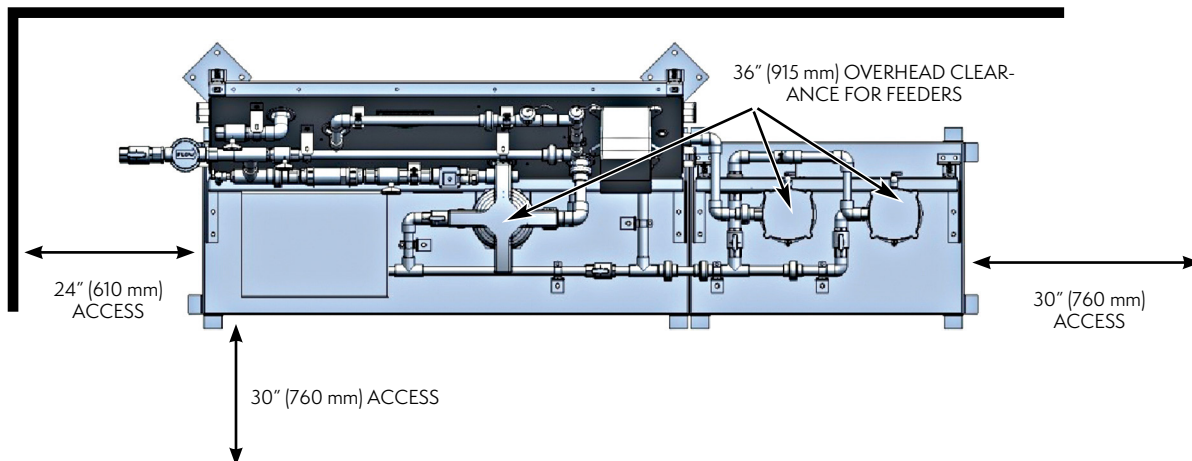

Figure 2 – Top View of System with Required Access

2.3 The **MRF** system consists of four modules: **BCF-NX**, Podium, Podium Support, and **MRF**. See Figure 3.

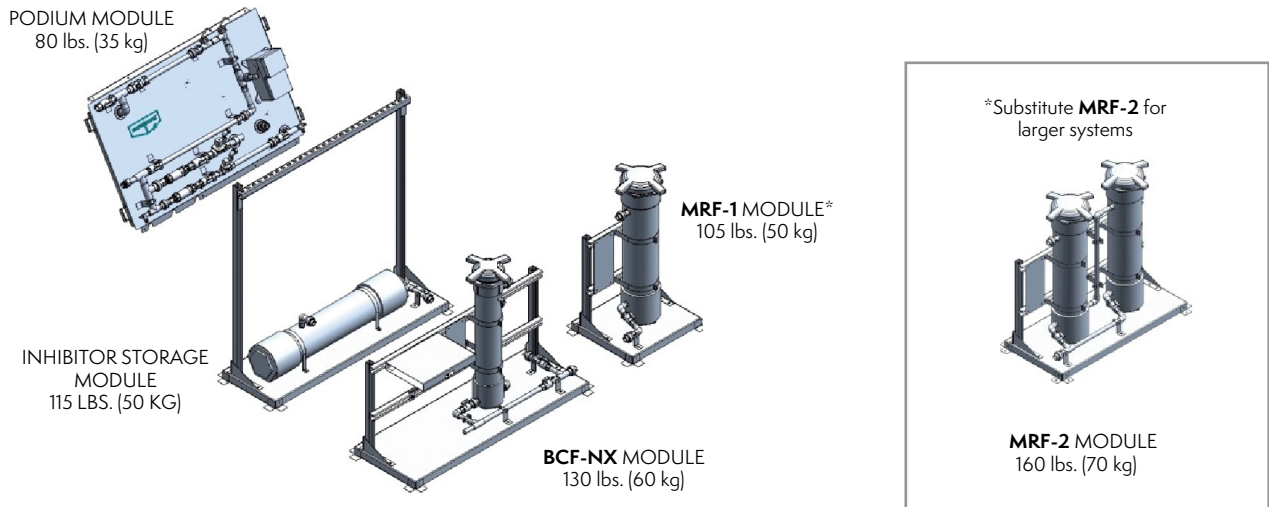

Figure 3 – MRF System Overview of Modules

- 2.4 **DO NOT** remove the Podium Module from the shipping crate until it is ready to be installed on the Upper and Lower Podium Support Frames. Care should be taken while moving and installing the Podium Module to avoid damage to the podium’s piping and wiring.
- 2.5 Set the Inhibitor Storage Module in desired location. Secure (2) Vertical Struts to the (2) Strut Brackets using the supplied hardware. See Figures 4 and 5.

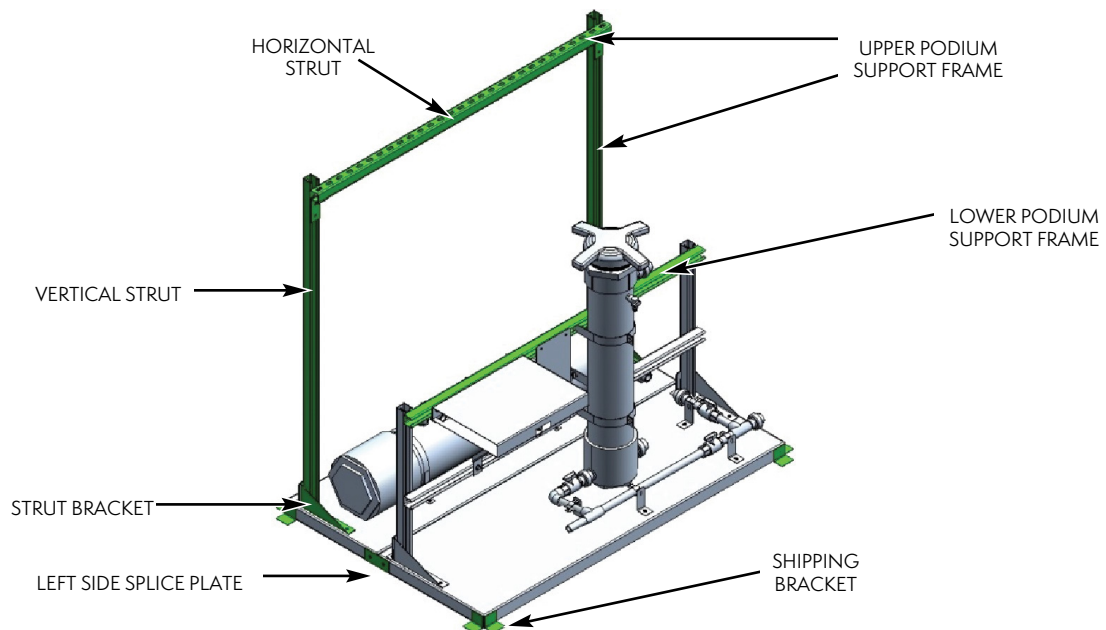

Figure 4 – Assemble **BCF-NX** and Inhibitor Storage Modules

- 2.6 Attach the Horizontal Strut, open side down, to the supports using the supplied hardware to complete the Upper Podium Support Frame. See Figures 4 and 5.
- 2.7 Set the **BCF-NX** Module in front of the Inhibitor Storage Module. It will be necessary to remove shipping brackets to properly join modules. Reuse shipping bracket hardware to attach the splice plate to the left side of the Inhibitor Storage Module to the **BCF-NX** Module. See Figure 4.

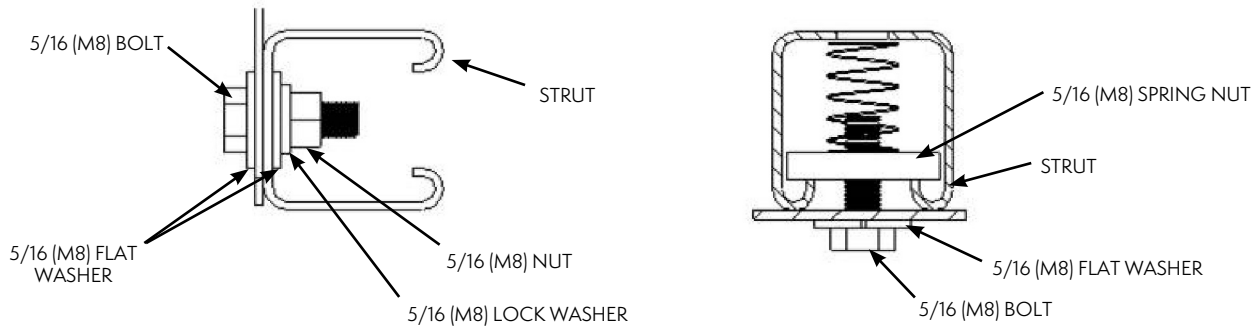

Figure 5 – Typical Hardware Details

2.8 **Before removing the Podium Module from its shipping assembly:** Remove supplied hardware from upper and lower flanges of the Podium Module. Unscrew conductivity probe and flow switch from piping and secure their O-rings. See Figure 6.

2.9 **This step requires 2 people:** Rest the Upper Podium Flange over the Upper Podium Support as shown in Figure 8, making sure that the probe wiring is clear of the podium support. Loosely secure the Lower Podium Flange to the rear of the Lower Podium Support. Then loosely secure the Upper Podium Flange. This hardware will be tightened after piping is completed. See Figure 8. Reinstall conductivity probe and flow switch into their respective manifolds, first making sure that O-rings are in place. See Figure 7.

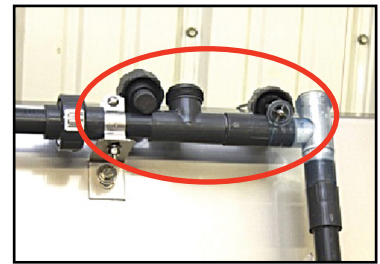

Figure 6 – Probe and Flow Switch

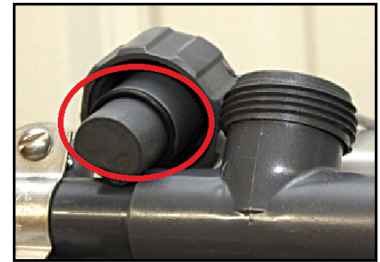

Figure 7 – O-Ring for Conductivity Probe

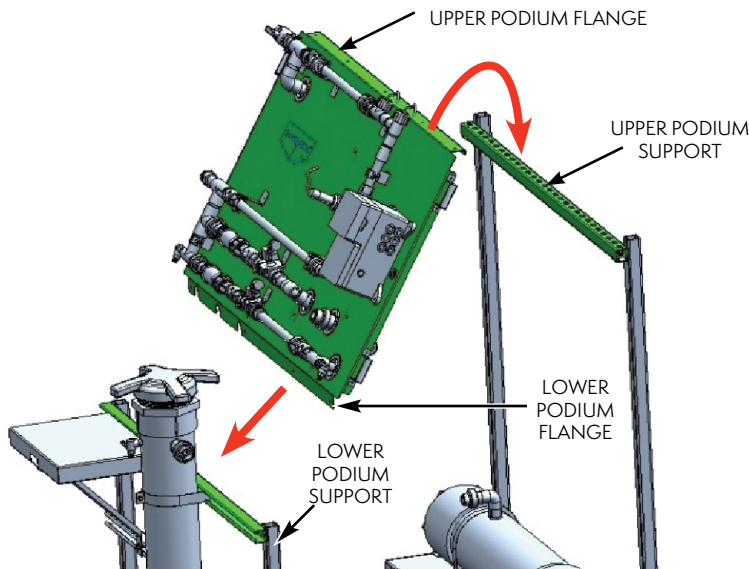

Figure 8 – Mount Podium Module

- 2.10 Connect the **MRF** Module to the right side of the **BCF-NX** Module. It will be necessary to remove shipping brackets to properly join modules. Reuse shipping bracket hardware to attach the supplied splice plates across the front and rear joints between modules. See Figure 9.

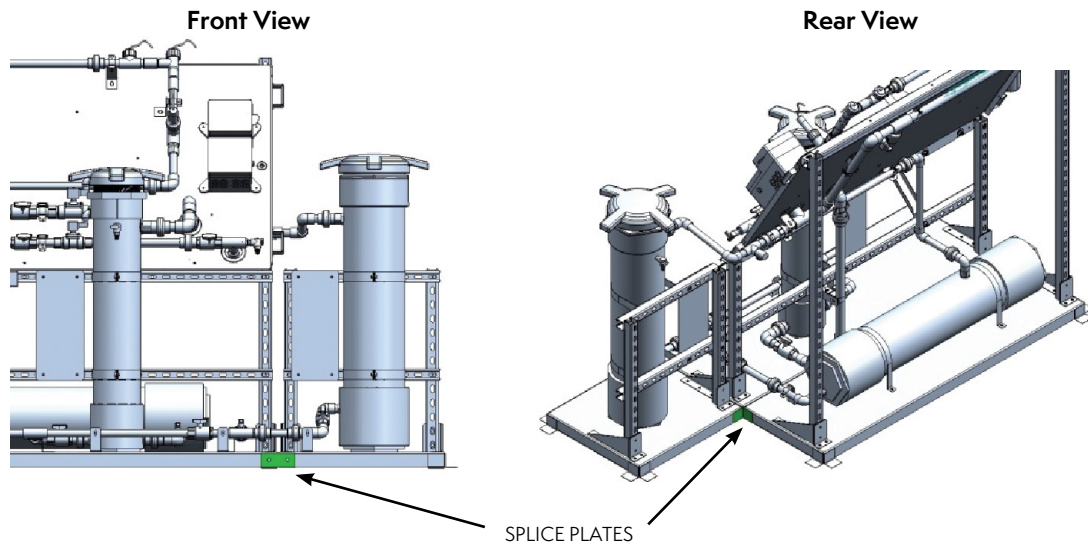

Figure 9 – Attach MRF Module

- 2.11 Complete the piping by installing the eight (8) shipped loose sections shown in green. Pipe sections include union fittings for tool-free installation. Verify that O-rings are in place prior to making each connection. O-rings, shown in Figure 12, are required on every union. The Supply Strainer and Isolation Valve section has a threaded connection. Use recommended thread sealant for this installation. See Figures 10, 11 and 12.

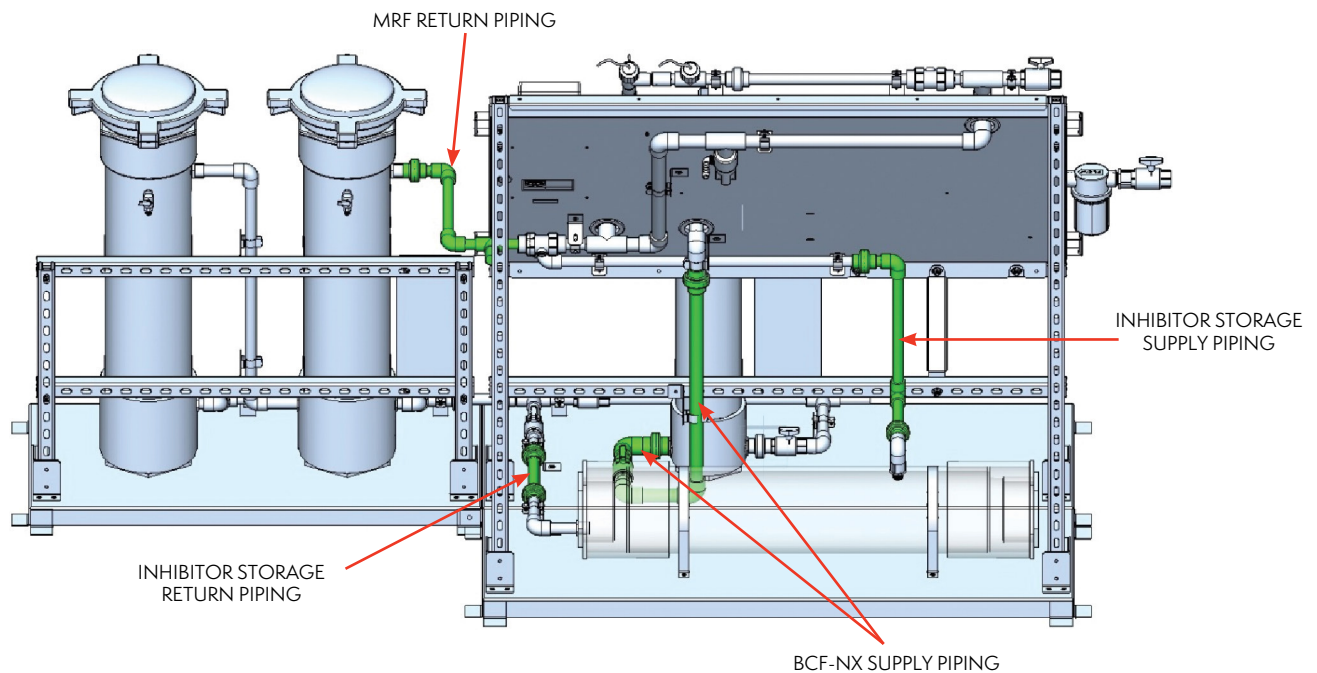

Figure 10 – Rear View of Piping

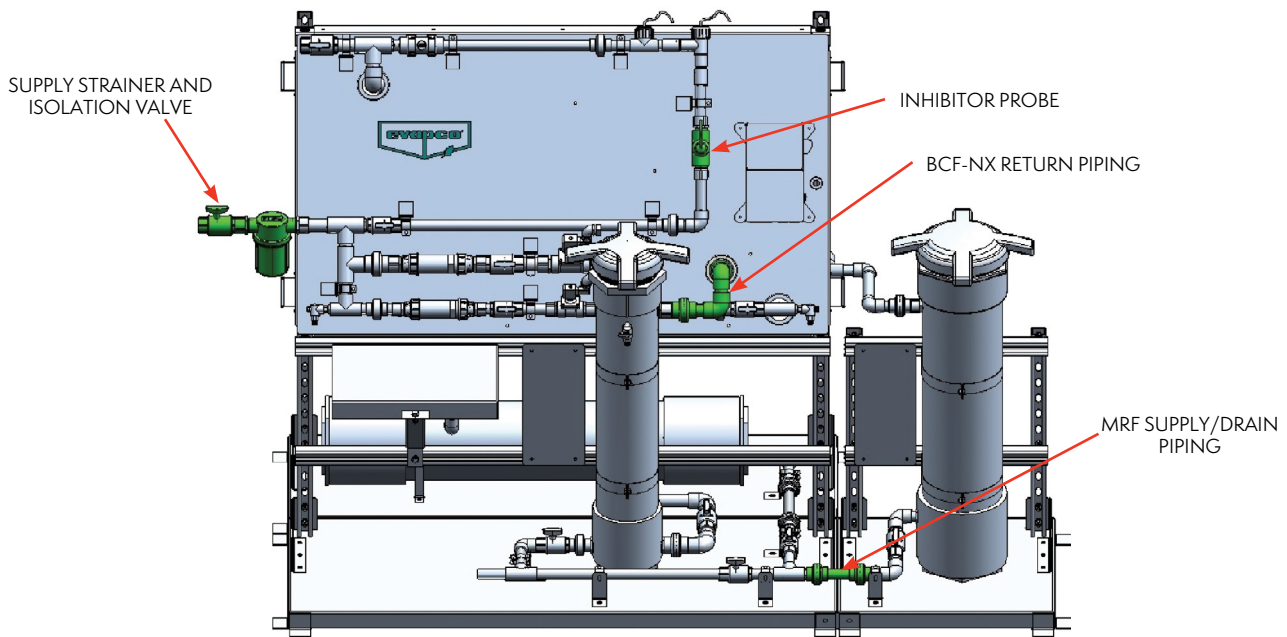

Figure 11 – Front View of Piping

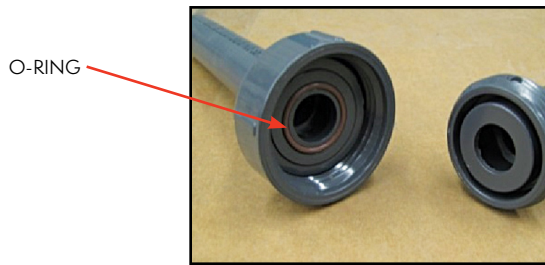

Figure 12 – Verify Union O-Ring Placement Prior to Making Connections

- 2.12 Once piping is completely installed, tighten podium flange hardware ensuring podium is secure. Reference Section 2.9 and Figure 8.
- 2.13 Install inhibitor probe into probe manifold, first ensuring O-ring is in place. See Figure 11. Refer to wiring diagram provided in submittal or conductivity controller IO&M for details.

### 3.0 MRF System Installation

General installation arrangements are shown in Figures 14, 15, 16, and 17. For special installations not covered in this manual, please consult your EVAPCO Representative or Authorized Water Systems Service Provider. The **MRF** system is designed to be installed on the floor inside a mechanical room.

#### 3.1 General **MRF** System Installation Requirements

- 3.1.1 Pipe supply water to the **MRF** from the high pressure side of the system (pump discharge), upstream of metering valves and process heat exchangers. **MRF** supply piping shall be 1" (32 mm) minimum schedule 80 (PN16) PVC.
- 3.1.2 Pipe return water from the **MRF** to the low pressure side of the system (pump suction) or to the remote sump. **MRF** return piping shall be 1" (32 mm) minimum schedule 80 (PN16) PVC.



- 3.1.3 Each header tap shall include an isolation valve at the header, supplied by others. See Figure 13 for recommended pipe tap locations.

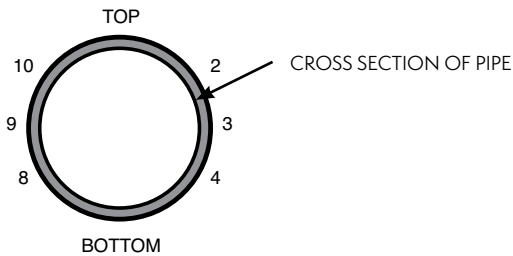

Figure 13 – Pipe Taps Shall be Between 2-4, or 8-10. Not on Top or Bottom of a Pipe.

- 3.1.4 The desired operating pressure differential is 15 psi (100 kPa). If operating pressure differential is less than 12 psi (80 kPa), or you have any questions, consult your EVAPCO Representative or Authorized Water Systems Service Provider.
- 3.1.5 Pipe the 3/4" (25 mm) **MRF** drain connection to sanitary drain using hard pipe, providing for gravity flow.
- 3.1.6 Connect the two (2) pressure relief valves to the sanitary drain noted above. Pressure relief valves are fixed at 125 psi (860 kPa).
- 3.1.7 **MRF** and **BCF-OX** systems require separate return piping to the low pressure side (pump suction) of the evaporative cooling system.
- 3.1.8 See **BCF-OX** section (Section 8.0) for additional installation details.
- 3.1.9 Supply field 120/230 VAC field power to the conductivity controller. Refer to wiring diagrams provided in submittal or controller IO&M for details.

3.2 Open Tower Schematics

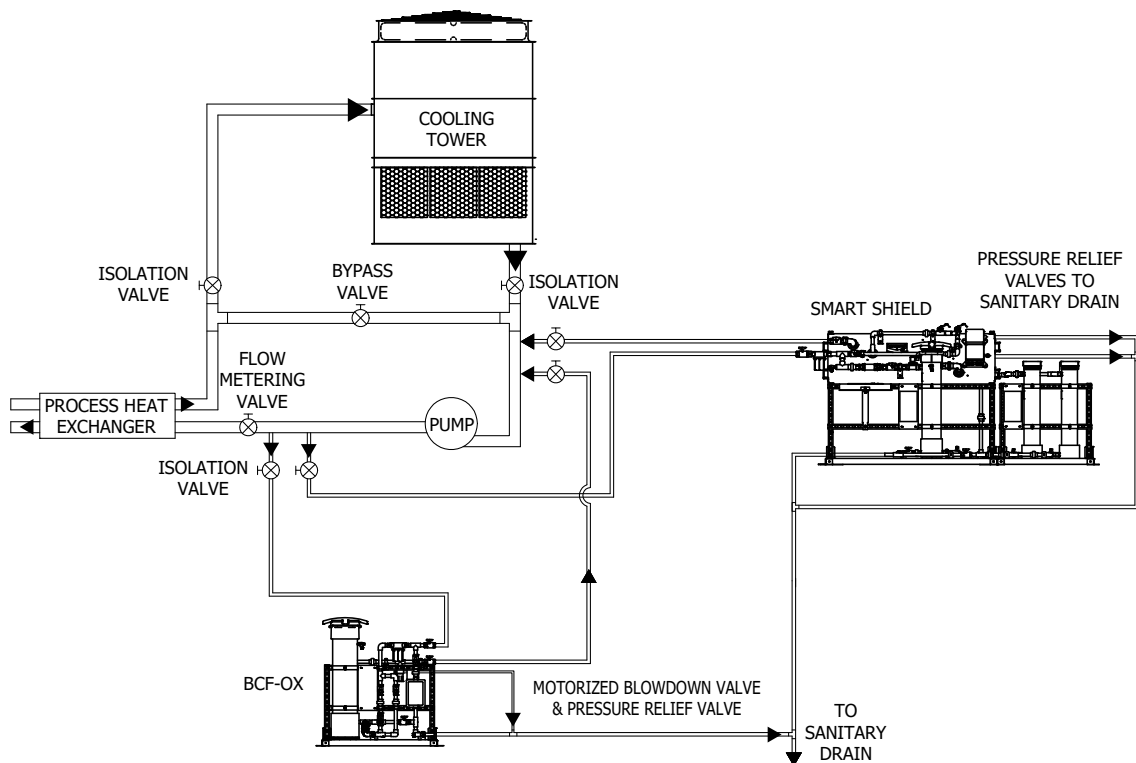
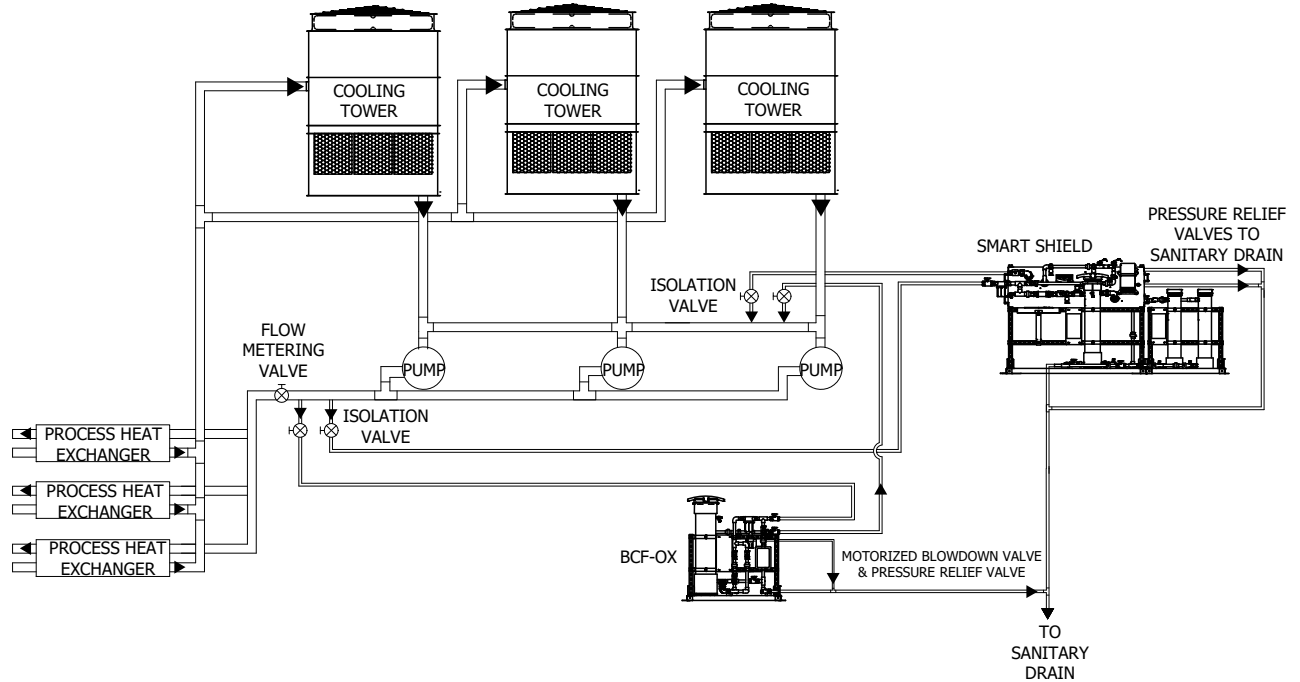
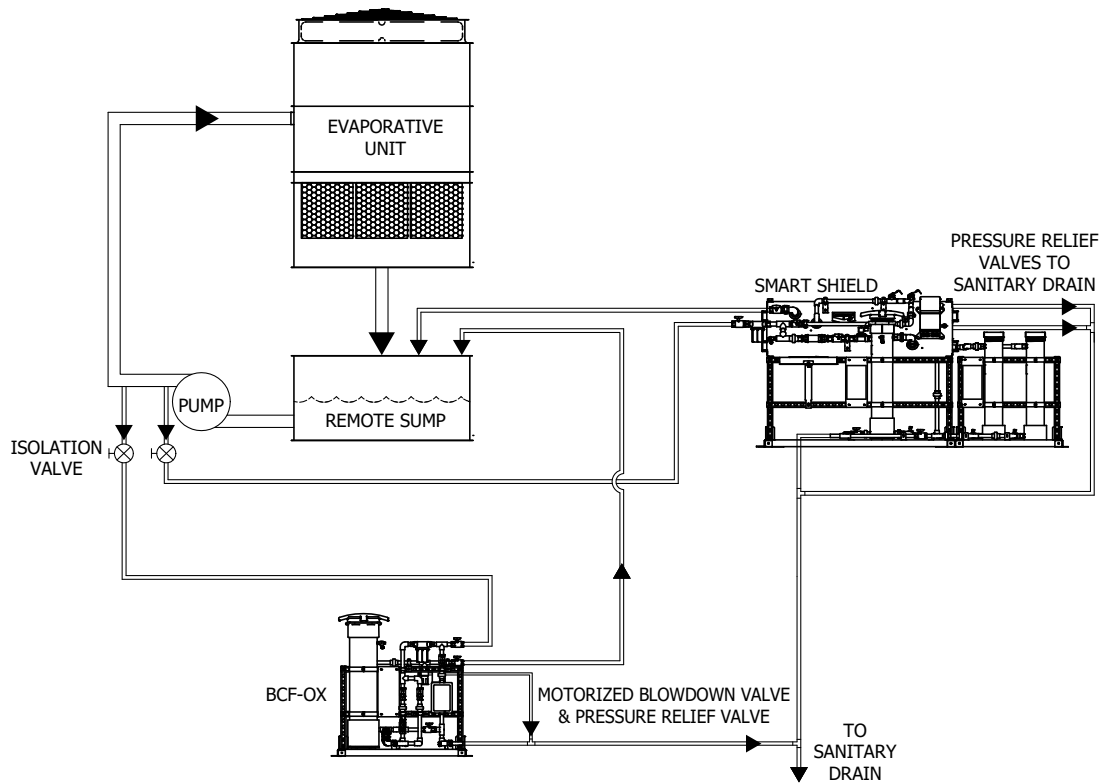

Figure 14 – General Smart Shield® Installed Arrangement in a System with a Single Cooling Tower Unit with Integral Sump (pump suction operation)

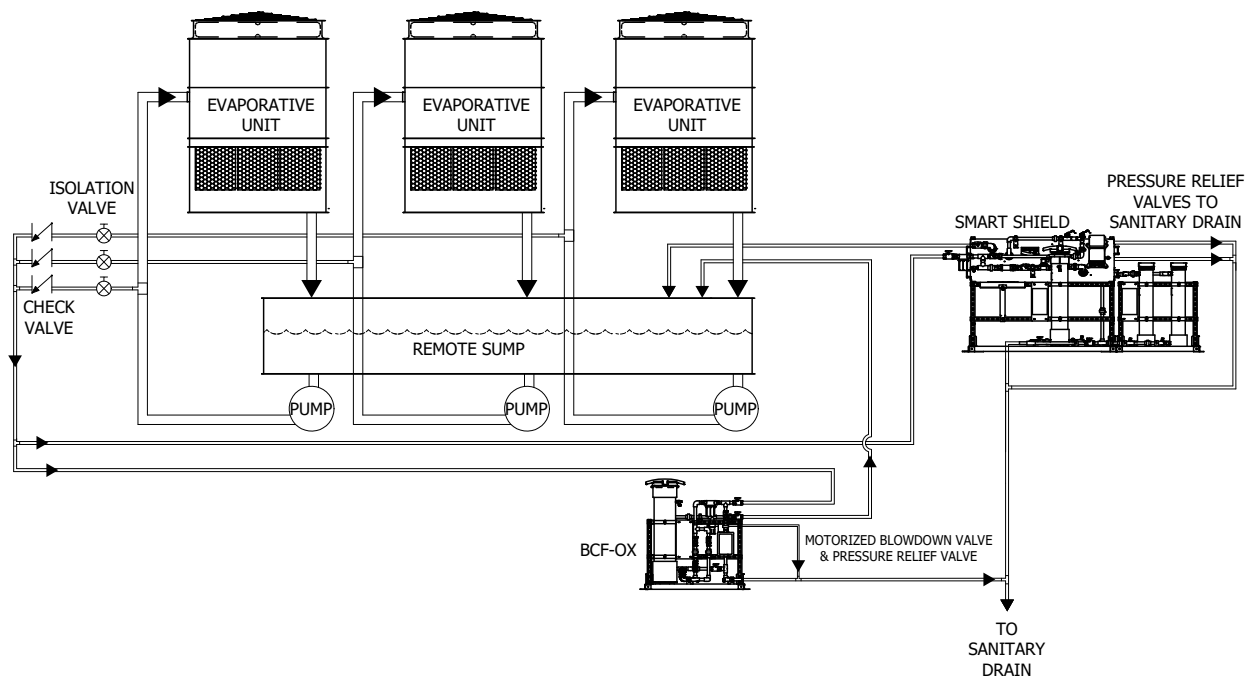

**Figure 15** – General Smart Shield® Installed Arrangement in a System with Multiple Cooling Tower Units with Integral Sump (pump suction operation)

### 3.3 Remote Sump Schematics



**Figure 16** – General Smart Shield® Installed Arrangement in a System with a Single Evaporative Cooling Unit with Remote Sump



**Figure 17** – General Smart Shield® Installed Arrangement in a System with Multiple Evaporative Cooling Units with Single Remote Sump

## 4.0 Conductivity Controller

For details of operation and configuration see the Installation, Operation, and Maintenance (IO&M) Manual for the specific conductivity controller provided with your Smart Shield® system. Refer to wiring diagrams provided in submittal or controller IO&M for relay designations.

## 5.0 MRF System Startup

Contact your EVAPCO Representative or Authorized Water Systems Service Provider at least three business days prior to adding water to the evaporative cooling system for startup.

- 5.1 Configure the controller per EVAPCO's site specific instructions. Contact your Authorized Water Systems Service Provider for your site specific configuration.
  - 5.1.1 Program the conductivity set point per the EVAPCO site specific SSF1.0 form.
  - 5.1.2 Configure the biocide feed schedules per EVAPCO's recommendations. Verify that the feed times are set for normal periods of wet operation.
    - 5.1.2.1 The **BCF-NX** timer should be programmed to feed 2-3 days per week. Program feed and post feed bleed lockout time.
    - 5.1.2.2 For semi-continuous timed feed, the **BCF-OX** timer should be programmed to feed based on EVAPCO's site specific recommendations.
  - 5.1.3 Verify that all relays are interlocked with the flow switch to prevent feeding chemistry or bleeding when the system pumps are offline.
- 5.2 Ensure all normally closed (NC) valves are closed and normally open (NO) valves are open.
- 5.3 Open Isolation Valves and set flow control valves. See Figure 18. The flow control valves should **NOT** be used to isolate piping.

- 5.3.1 With all solenoids closed (set **BCF-NX** Solenoid Relay and **MRF** Solenoid Relay to 'H-OFF' [hand off]), adjust Conductivity Flow Control Valve to approximately 4 GPM (15 LPM). A flow rate between 3-5 GPM (10-20 LPM) is desired. The flow switch requires 2-3 GPM (7-10 LPM) to register flow, then continue to open valve to achieve approximately 4 GPM (15 LPM).
- 5.3.2 Using the controller keypad, manually energize **MRF** Solenoid Relay ('H-ON' [hand on]). Adjust flow to 0.5 GPM (2 LPM) using the **MRF** Flow Control Valve and reading rate from the Flow Meter.
- 5.3.3 Using the controller keypad, manually energize **BCF-NX** Solenoid Relay ('H-ON'). Adjust flow to specified rate using the **BCF-NX** Flow Control Valve and reading rate from the Flow Meter. Contact your Authorized Water Systems Service Provider if additional information is needed. Ensure Flow Switch is still activated and **MRF** flow is still at 0.5 GPM (2 LPM). Adjust as needed. Ensure both **MRF** and **BCF-NX** Solenoid Relays are back in automatic control based on the programmed schedule ('OFF/ON').
- 5.3.4 Calibrate conductivity and inhibitor probes. See separate IO&Ms for detailed instructions. (Section 4.0).

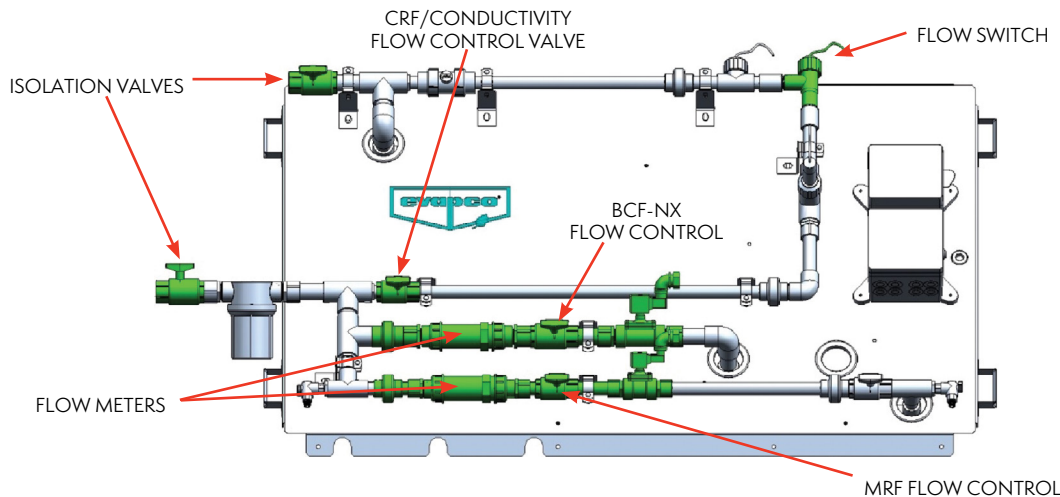

**Figure 18** – Flow Control

- 5.4 See **MRF**, **BCF-NX**, and **BCF-OX** sections for details on replenishment chemistry loading.

## 6.0 Monitored Release Feeder (MRF)

The Monitored Release inhibitor feed system is engineered to accurately release corrosion and scale inhibitor into the recirculating water of an evaporative cooling system during periods of wet operation. When system pumps are in operation, the inhibitor probe continuously measures the inhibitor level in the recirculating water providing feedback to the controller. The continuous monitoring of inhibitor level provides tight control, even as the evaporative load fluctuates.

### 6.1 MRF Configuration

The Monitored Release inhibitor feed system is supplied with 1 or 2 **MRF(s)**, an inhibitor storage reservoir, and an inhibitor probe. Each reservoir and feeder is equipped with isolation valves and a vent for draining. A 125 psi (860 kPa) pressure relief valve is located in the **MRF** feed loop downstream of the feeders. The inhibitor storage reservoir is designed to recover remaining chemistry from the **MRF** feeders during reloading. The inhibitor probe is installed on the control podium in the continuous monitoring loop manifold. The **MRF** solenoid is energized when the inhibitor level, as measured by the inhibitor probe, drops below the set point. See Figure 19.

### 6.2 MRF Piping

The recirculating water flows into the **MRF** feed loop from the supply through the 20 mesh strainer to the **MRF** Flow Control Valve and Solenoid. When the controller initiates feed, the **MRF** Solenoid is energized allowing flow through the Inhibitor Storage Reservoir, through the **MRF(s)**, and back to the recirculating water system. The Inhibitor Storage Reservoir and the Monitored Release Feeder(s) are piped in series such that the storage reservoir exhausts its chemistry first, followed by the **MRF-2** (when provided), and then **MRF-1** exhaust last. See Figure 19.

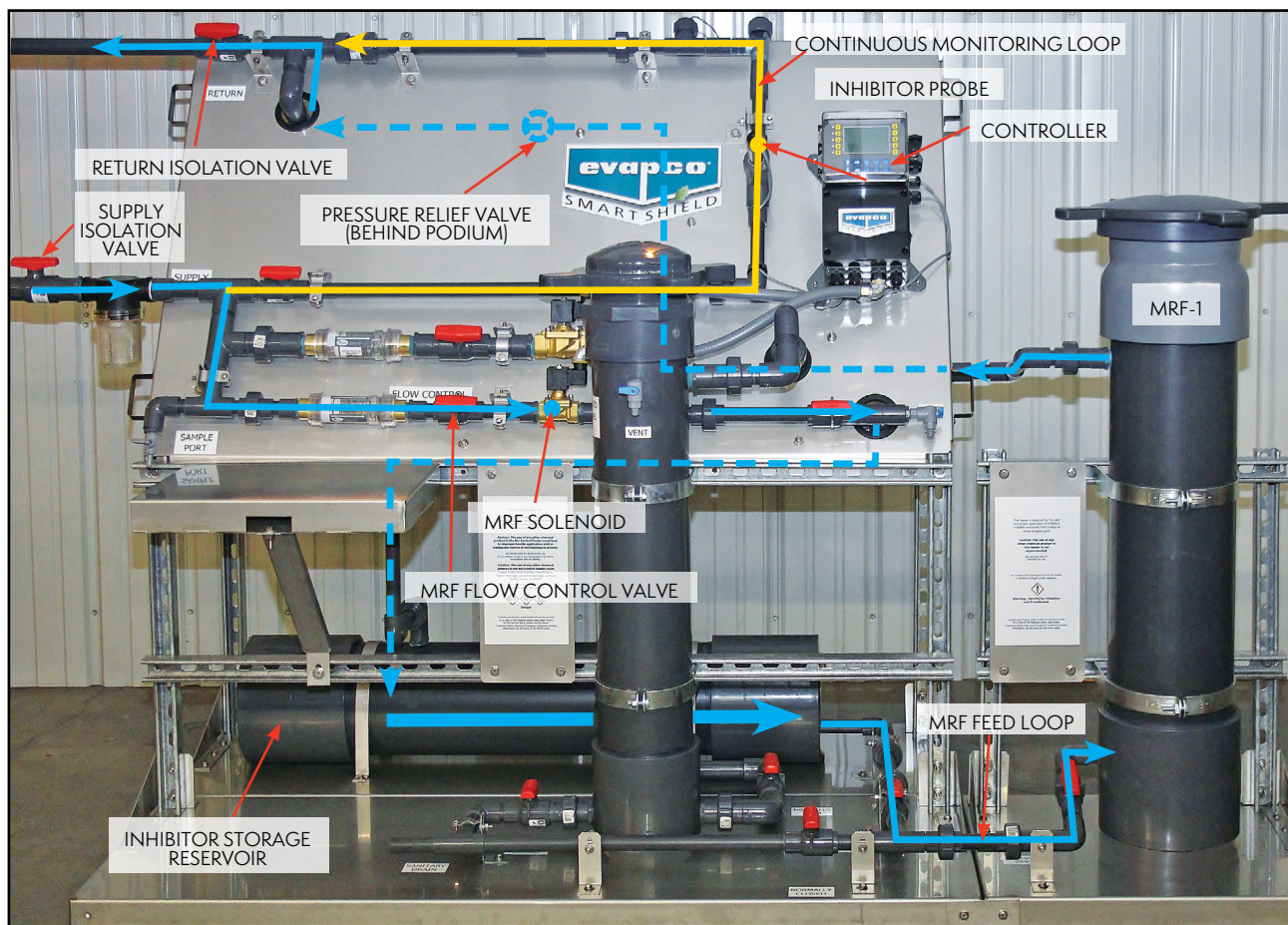

Figure 19 – MRF Flow Path during Feed

### 6.3 Loading the **MRF**

- 6.3.1 The **MRF** can be loaded while the remainder of the system continues to operate. Prior to loading the feeder(s), shown in Figure 20:
- 6.3.1.1 Close the Inhibitor Loop Isolation Valve (see Figure 20 on next page). Verify Storage Reservoir Isolation Valve is open. **DO NOT** use flow valves for isolation.
  - 6.3.1.2 Close the normally open (NO) **MRF** Supply/Drain Valve(s).
  - 6.3.1.3 Open the Inhibitor Loop Drain Valve.
  - 6.3.1.4 Open the Storage Reservoir Vent allowing the storage reservoir to drain to sanitary drain.
  - 6.3.1.5 Close the Inhibitor Loop Drain Valve.
  - 6.3.1.6 Open the **MRF** Supply/Drain Valve and Vent for the feeder closest to the podium. This will drain any residual dissolved chemistry into the storage reservoir for reuse. Open the feeder(s) by rotating the **MRF** lid(s) counter-clockwise to verify feeder is draining.
  - 6.3.1.7 Close the **MRF** Supply/Drain Valve for the feeder closest to the podium.
  - 6.3.1.8 If there is an additional **MRF**, close the Storage Reservoir Isolation Valve. If there is not a second **MRF**, skip to 6.3.2.
  - 6.3.1.9 Open the Inhibitor Loop Drain Valve.
  - 6.3.1.10 Open the remaining **MRF** Supply/Drain Valve and Vent to discharge to sanitary drain (for a system with an **MRF-2**).
- 6.3.2 Open the feeder(s) by rotating the **MRF** lid(s) counter-clockwise. Add the desired quantity of Monitored Release inhibitor chemistry beginning with the last **MRF** in series.
- 6.3.3 Inspect the lid(s) to ensure O-ring(s) are present, lubricate as needed using a non-petroleum based lubricant, and replace the lid(s). The lid(s) should be secured hand tight. **DO NOT** use tools to tighten. **DO NOT** over tighten.

6.3.4 Return valves to operating position.

- Closed Inhibitor Loop Drain Valve
- Open Storage Reservoir Isolation Valve
- Open **MRF** Supply/Drain Valve for the first **MRF** in series (normally open valve)
- Closed All other **MRF** Supply/Drain Valves
- Closed Storage Reservoir Vent

6.3.5 Controller logic must be reset each time the **MRF** is loaded with chemistry. Using the controller keypad reset controller 'Fuzzy Response' to 1%, by selecting 'Setup/Run', then the 'Setpoints' menu. From this menu, select 'mA in', then 'Input 1'. From the 'Input 1' menu, select 'Setpoints', then 'Fuzzy Response'. Once in the 'Fuzzy Response' screen, use the keypad to change the value to 1%, and then press enter to accept the changed value. See controller IO&M for detailed instructions.

6.3.6 Open the Inhibitor Loop Isolation Valve. Use the controller to set the **MRF** Solenoid Relay into 'H-ON'. Allow air to bleed from the feeder with the Vent(s) open. Once air has bled, close the Vent(s). Ensure the flow meter is registering proper flow and confirm the **MRF** Solenoid Relay is back in automatic operation ('OFF/ON').

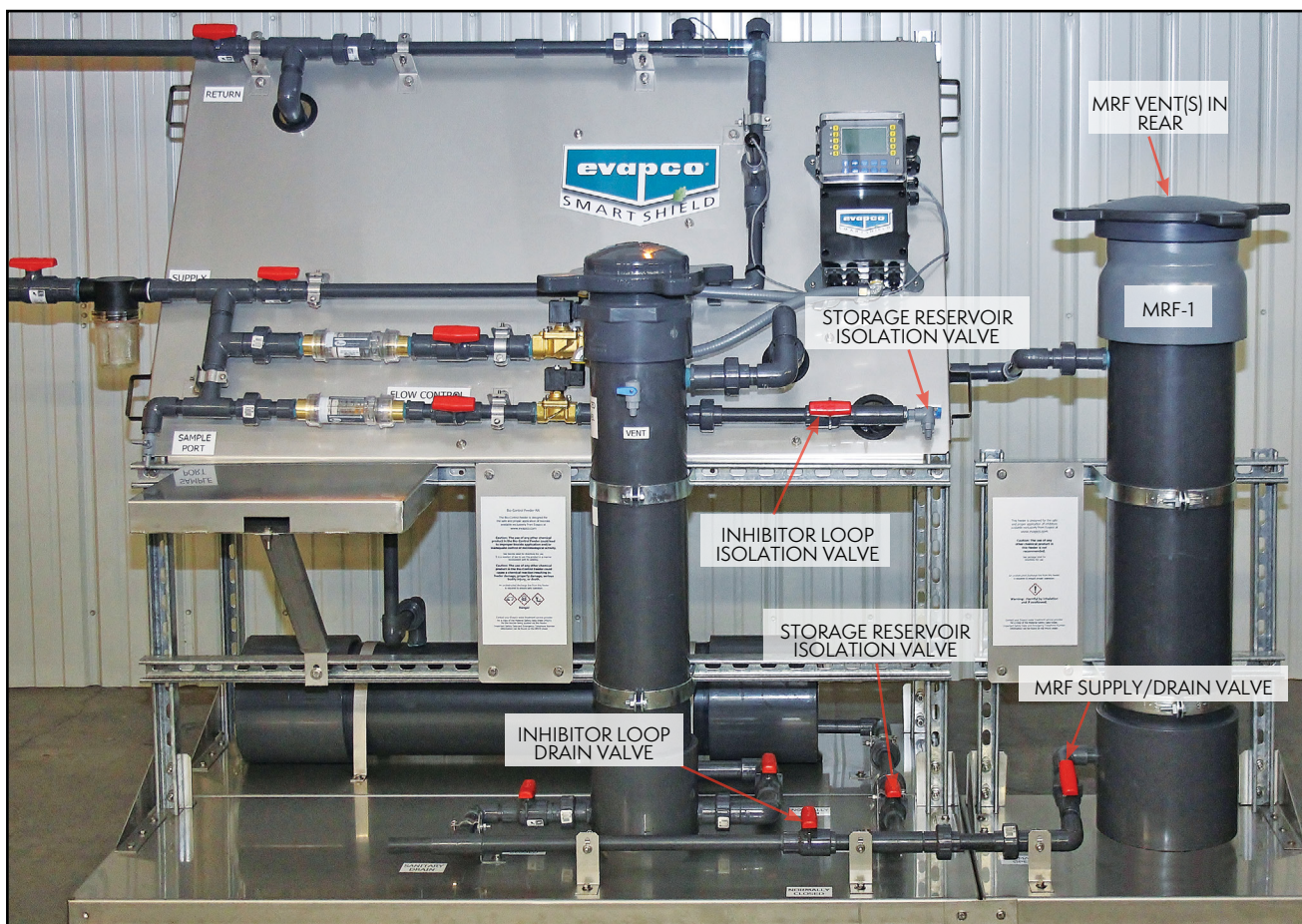

Figure 20 – Loading the MRF

6.4 Replenishment Chemistry

Each **MRF** can hold up to 36 lbs. (17 kg) of MR inhibitor chemistry. Contact your EVAPCO Representative or Authorized Water Systems Service Provider for the amount of chemistry to be loaded for your system. **DO NOT** use any unapproved chemistry in the **MRF**. The chemistry is supplied in easy-to-handle pourable bags. Refer to the **MRF** label and the MR inhibitor Material Safety Data Sheet (MSDS) prior to use.

6.5 Periodic Testing

Periodic testing by an EVAPCO Representative or Authorized Water Systems Service Provider must be performed to verify that the system is operating as designed.

## 7.0 Bio-Control Feeder BCF-NX

The **BCF-NX** biocide feeder is engineered to provide consistent feed of non-oxidizing biocide over a 30-day period of operation.

### 7.1 BCF-NX Configuration

The **BCF-NX** feeder is equipped with isolation valves and a vent for draining. A 125 psi (860 kPa) pressure relief valve is located in the **BCF-NX** feed loop downstream of the feeder. The controller must be programmed to energize the feed solenoid two or three times per week. Biocide release from the feeder can be controlled by adjusting the feed duration and/or the flow rate through the feeder. See Figure 21.

### 7.2 BCF-NX Piping

The recirculating water flows into the **BCF-NX** feed loop from the supply through the 20 mesh strainer to the **BCF-NX** Flow Control Valve and Solenoid. When the controller's timer initiates feed, the **BCF-NX** Solenoid is energized allowing flow through the feeder and back to the recirculating water system. See Figure 21.

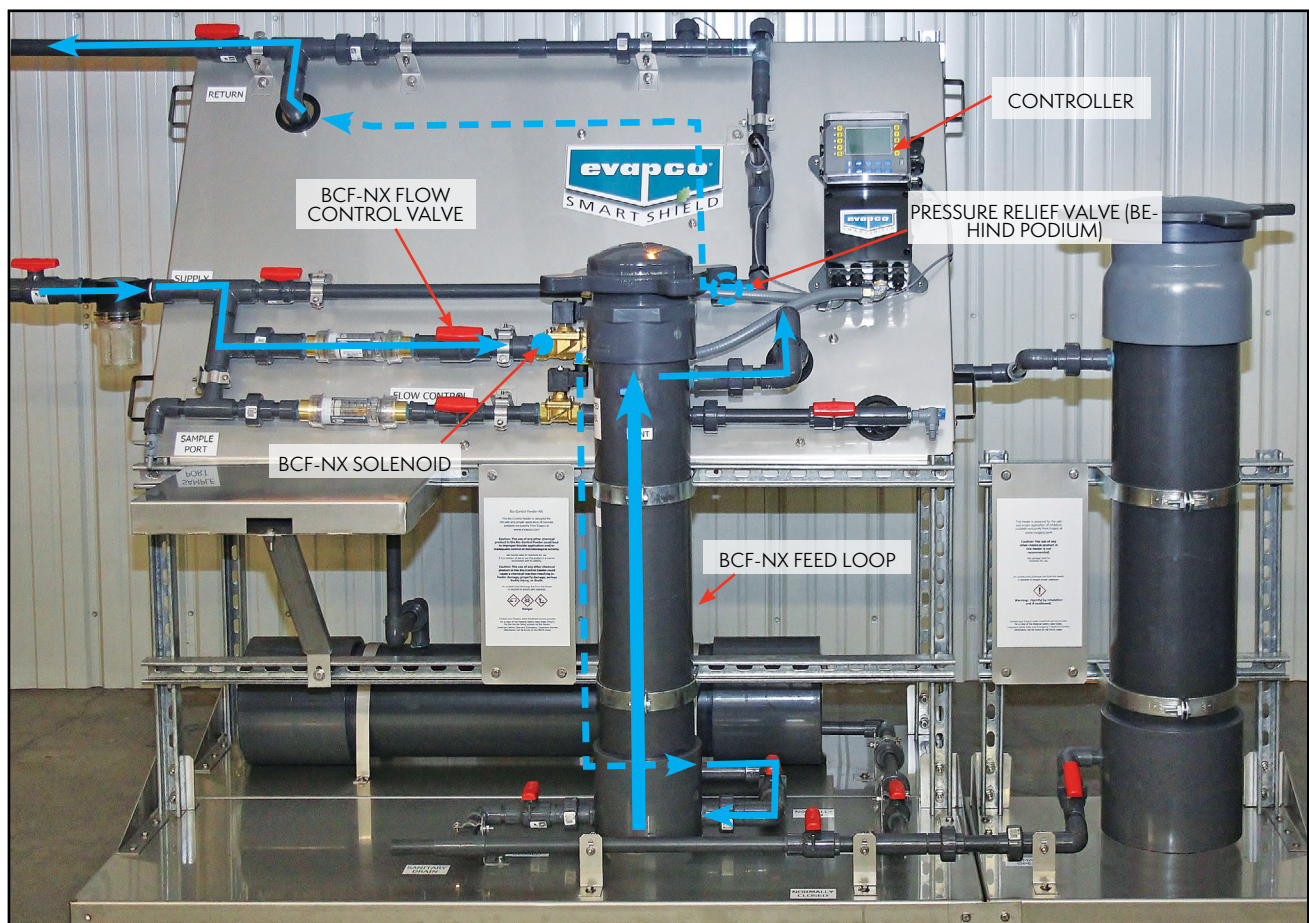

Figure 21 – BCF-NX Flow Path during Feed

### 7.3 Loading the BCF-NX

7.3.1 Read all posted labels and placards prior to opening this feeder. Contact your EVAPCO Representative or Authorized Water Systems Service Provider prior to opening feeder.

7.3.2 It is important to flush dissolved biocide from the feeder back into the recirculating water prior to loading. With the system pump in operation, use the controller's 'H-ON' control feature to energize the **BCF-NX** Solenoid Relay. Flush the feeder for approximately 3 minutes then confirm the relay has returned to automatic operation ('OFF/ON').

**CAUTION:** Failure to flush feeder before opening may increase the potential for vapor release or other hazards.

- 7.3.3 Close the Supply and Return Isolation Valves on the **MRF** system. See Figure 22.
- 7.3.4 Open the **BCF-NX** Drain Valve and then the Vent to drain the feeder to sanitary drain. Note that it may not be necessary to completely drain the feeder for reloading. See Figure 22.
- 7.3.5 Once feeder is drained, close the **BCF-NX** Drain Valve and then open the feeder by rotating counter-clockwise to remove **BCF-NX** lid. Add the required amount of biocide to the feeder. **DO NOT** overload feeder.
- 7.3.6 Inspect the lid to ensure O-ring is present, lubricate as needed using non-petroleum based lubricant, and replace the lid. The lid should be secured hand tight. **DO NOT** use tools to tighten. **DO NOT** over tighten.
- 7.3.7 Open the Return and then Supply Isolation Valves. Use the controller to set the **BCF-NX** Solenoid Relay to 'H-ON'. Allow air to bleed from the feeder with the Vent open. Once air has bled, close the Vent. Ensure the flow meter is registering proper flow and confirm the **BCF-NX** Solenoid Relay is back in automatic operation ('OFF/ON').

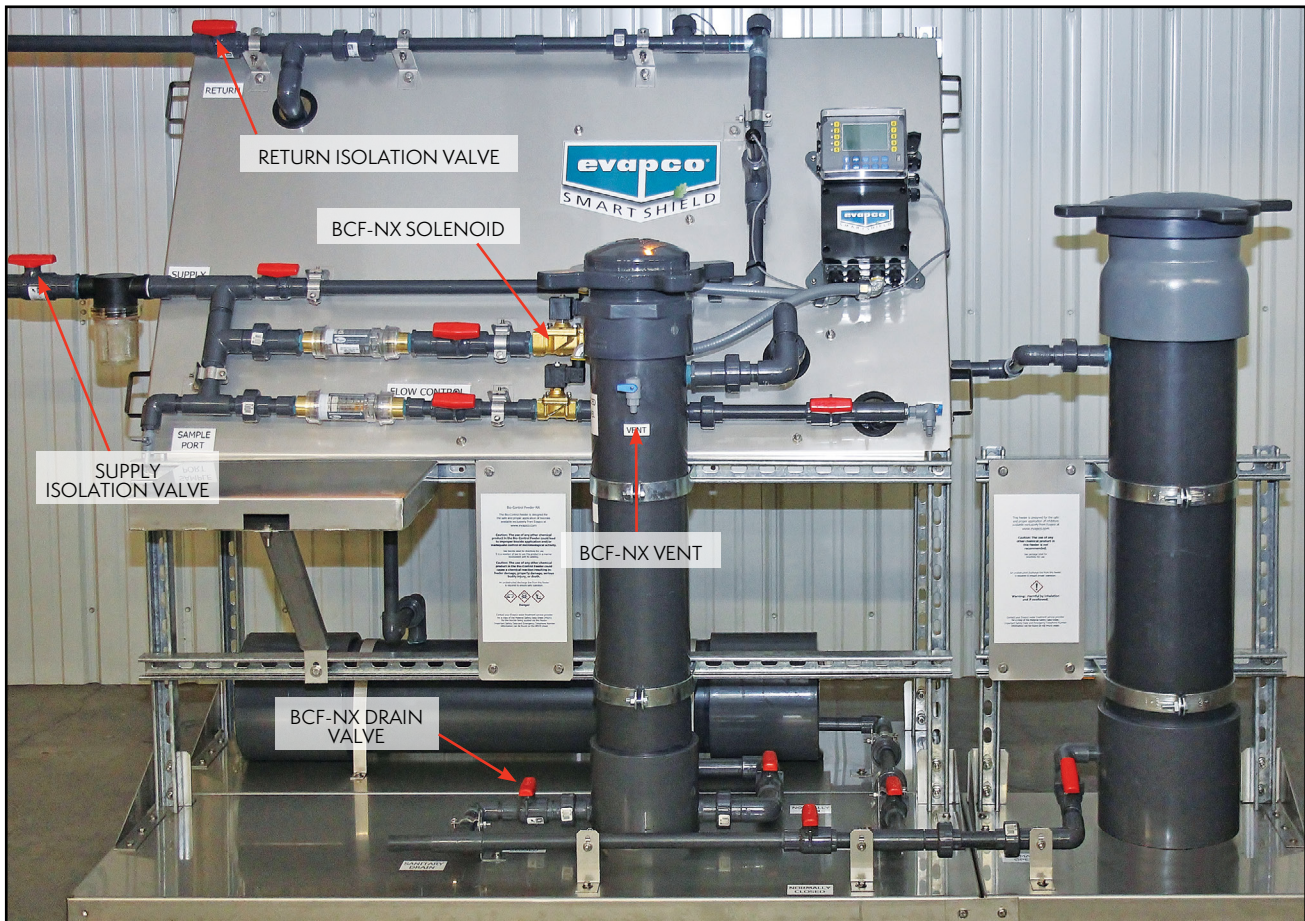

**Figure 22 – Loading the BCF-NX**

#### 7.4 Replenishment Chemistry

The **BCF-NX** can hold up to 20 lbs. (10 kg) of non-oxidizing biocide. Contact your EVAPCO Representative or Authorized Water Systems Service Provider for the type and amount of chemistry to be loaded into your system. Refer to the **BCF-NX** label and the biocide Material Safety Data Sheet (MSDS) prior to use. **CAUTION:** The use of any other chemical product in the **BCF-NX** could cause a chemical reaction resulting in feeder damage, property damage, serious bodily injury, or death.

#### 7.5 Periodic Testing

Periodic testing by an EVAPCO Representative or Authorized Water Systems Service Provider must be performed to verify that the system is operating as designed and to adjust the feed timer duration and chemistry amount based on changes in system load, ambient conditions, make-up water quality, or other local conditions.



## 8.0 Bio-Control Feeder BCF-OX

The **BCF-OX** oxidizing biocide feeder is engineered to provide semi-continuous timed feed of oxidizing biocide over a 30-day period of operation. There are two **BCF-OX-D** models to accommodate varying system sizes and demand.

### 8.1 Installation

The **BCF-OX** module is installed in conjunction with the **MRF** system in a mechanical room, as described in Section 3.0. Before installation, consider the location of the recirculating water’s supply and return taps in the system piping headers. Each header tap should include an isolation valve at the header and be installed on the side of the pipe (see Figure 13). Also consider sanitary drain location. Drain piping should provide for gravity flow. The **BCF-OX** module may be located against a wall or in a corner on the floor of the mechanical room. Allow sufficient space for supply, return, and drain piping. Allow a minimum of 30” (760 mm) unobstructed space in front and to one side of the skid for routine servicing. Allow a minimum of 36” (915 mm) unobstructed space above feeders for routine servicing. See Figures 23 and 24. General installation piping arrangements are shown in Section 3.2. For special installations not covered in this manual, please consult your EVAPCO Representative or Authorized Water Systems Service Provider. General **BCF-OX** installation requirements are listed below.

<b>BCF-OX</b> Model	LENGTH, in (mm)	WIDTH, in (mm)	HEIGHT, in (mm)	MINIMUM PIPING CONNECTION SIZES, in (mm)
OX-D15	40 (1020)	21 (535)	42 (1070)	3/4 (25 mm)
OX-D40	40 (1020)	21 (535)	45 (1154)	1 (32 mm)

Figure 23 – BCF-OX Module Dimensions

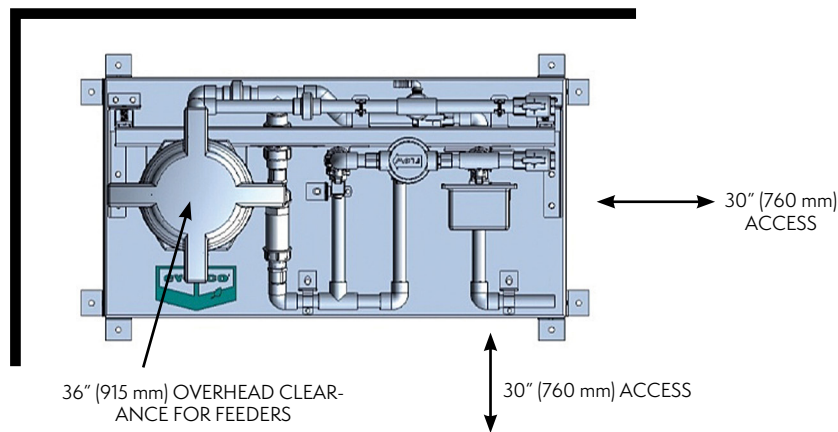

Figure 24 – Top View of Skid with Required Access

- 8.1.1 Pipe supply water to the **BCF-OX** from the high pressure side of the system (pump discharge), upstream of metering valves and process heat exchangers. **BCF-OX** supply piping shall be 3/4” (25 mm) or 1” (32 mm) schedule 80 (PN16) PVC. Use the minimum piping size for your **BCF-OX** model shown in Figure 23.
- 8.1.2 Pipe return water from the **BCF-OX** to the low pressure side of the system pump (pump suction) or to the remote sump. **BCF-OX** return piping shall be 3/4” (25 mm) or 1” (32 mm) schedule 80 (PN16) PVC. See Figure 23.
- 8.1.3 Each header tap shall include an isolation valve at the header (supplied by others) and be installed on the side of the pipe (see Figure 13).
- 8.1.4 The desired operating pressure differential is 15 psi (100 kPa). If the operating pressure differential is less than 12 psi (80 kPa), or you have any questions, consult your EVAPCO Representative or Authorized Water Systems Service Provider.

- 8.1.5 Pipe the 3/4" (25 mm) or 1" (32 mm) **BCF-OX** drain/bleed connection to sanitary drain using hard pipe, providing for gravity flow. Use the minimum piping size for your **BCF-OX** model shown in Figure 23.
- 8.1.6 Connect the pressure relief valve to the sanitary drain noted above. Pressure relief valve is fixed at 125 psi (860 kPa).
- 8.1.7 **MRF** and **BCF-OX** systems require separate return piping to the low pressure side (pump suction) of the evaporative cooling system. See Section 3.2.
- 8.1.8 Field wire the **BCF-OX** Solenoid (18 GA) and the blow down valve (18 GA) to the conductivity controller located on the **MRF** system. Refer to wiring diagrams provided in submittal or controller IO&M for details.

## 8.2 BCF-OX Startup

Contact your EVAPCO Representative or Authorized Water Systems Service Provider at least three business days prior to adding water to the evaporative cooling system for startup.

- 8.2.1 Open Supply and Return Isolation Valves. See Figure 25. The flow control valves should **NOT** be used to isolate piping.
- 8.2.2 Using the controller keypad, manually energize the **BCF-OX** Solenoid Relay ('H-ON'). Adjust flow to specified rate using the **BCF-OX** Flow Control Valve and reading the rate from the Flow Meter. Contact your Authorized Water Systems Service Provider if additional information is needed. Ensure the **BCF-OX** Solenoid Relay is back in automatic operation ('OFF/ON').
- 8.2.3 Using the controller keypad, manually energize the Blow Down Motorized Ball Valve Relay ('H-ON'); use the Blow Down Flow Control Valve to throttle the bleed rate. Ensure the Blow Down Motorized Ball Valve Relay is back in automatic operation ('OFF/ON').

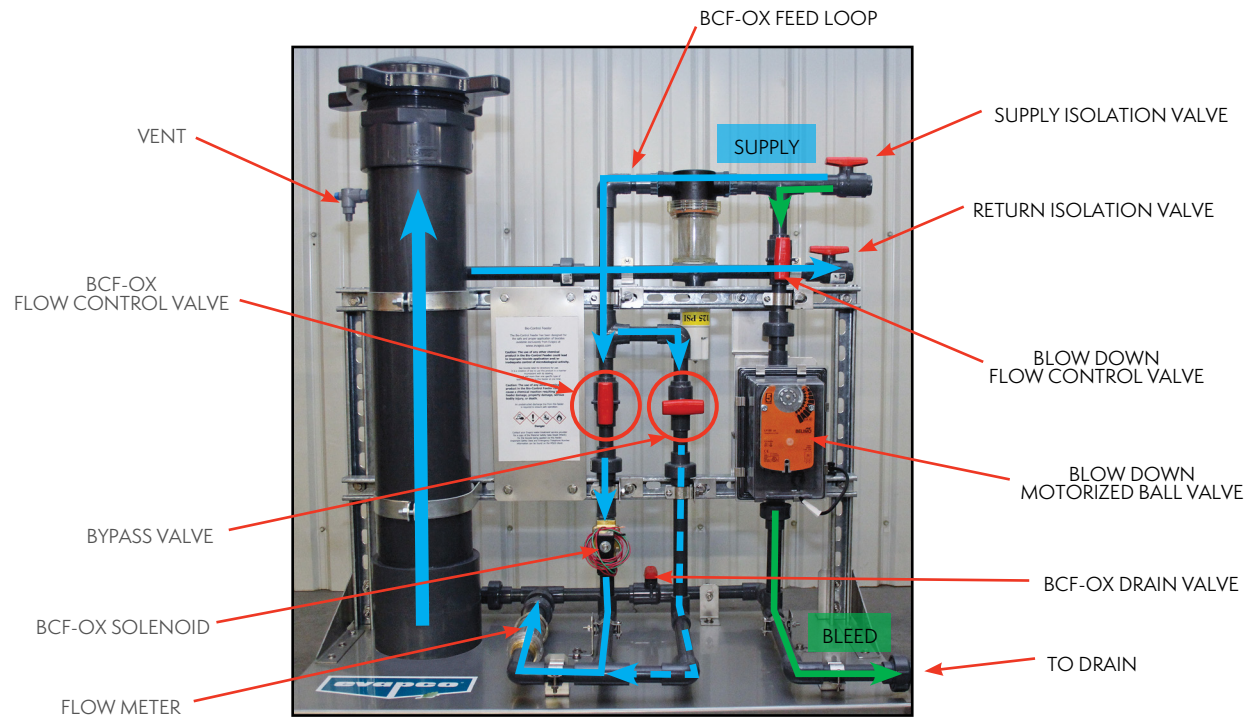

**Figure 25 – BCF-OX Flow Path during Feed or Bleed**

8.2.4 See 'Loading the **BCF-OX**' Section 8.5 for details on replenishment chemistry loading.

## 8.3 BCF-OX Configuration

The **BCF-OX** module is equipped with isolation valves and a vent for draining. A 125 psi (860 kPa) pressure relief valve is located in the **BCF-OX** feed loop downstream of the feeder. The controller must be programmed to energize the feed solenoid per EVAPCO's site specific recommendations. Biocide release from the feeder can be controlled by adjusting the feed duration and/or the flow rate through the feeder. The **BCF-OX** module is also equipped with a motorized ball valve for system bleed. See Figure 25.

#### 8.4 BCF-OX Piping

The recirculating water from the high pressure side (pump discharge) flows into the **BCF-OX** feed loop (indicated by blue arrows in Figure 25) from the supply through the 20 mesh strainer, and then to the **BCF-OX** Flow Control Valve and Solenoid. When the controller's timer initiates feed, the **BCF-OX** Solenoid is energized allowing flow through the feeder and back to the low pressure side (pump suction) of the recirculating water system. The Bypass Valve remains closed. When the system's conductivity exceeds the programmed set point, the controller initiates bleed. During system bleed, flow is diverted through the Blow Down Motorized Ball Valve and to drain (indicated by green arrows in Figure 25). Bleed flow is set using the Blow Down Flow Control Valve. See Figure 25.

#### 8.5 Loading the **BCF-OX**

- 8.5.1 Read all posted labels and placards prior to opening this feeder. Contact your EVAPCO Representative or Authorized Water Systems Service Provider prior to opening feeder.
- 8.5.2 It is important to flush dissolved biocide from the feeder back into the recirculating water prior to loading. Use the controller's 'H-ON' control feature to energize the **BCF-OX** Solenoid Relay. Flush the feeder for approximately 3 minutes then ensure the relay is back in automatic operation ('OFF/ON'). **CAUTION:** Failure to flush feeder before opening may increase potential for vapor release or other hazards.
- 8.5.3 Close the Supply and Return Isolation Valves on the **BCF-OX** module. See Figure 26.
- 8.5.4 Open the **BCF-OX** Drain Valve and then the Vent to drain the feeder to sanitary drain. Note that it may not be necessary to completely drain the feeder for reloading.
- 8.5.5 Once the feeder is drained, close the **BCF-OX** Drain Valve and then open the feeder by rotating counter-clockwise to remove **BCF-OX** lid. Add the required amount of biocide to the feeder. **DO NOT** overload feeder.
- 8.5.6 Inspect the lid to ensure O-ring is present, lubricate as needed using non-petroleum based lubricant, and replace the lid. The lid should be secured hand tight. **DO NOT** use tools to tighten. **DO NOT** over tighten.
- 8.5.7 Open the Return and then Supply Isolation Valves. Use the controller to set the **BCF-OX** Solenoid Relay into 'H-ON'. Allow air to bleed from the feeder with the Vent open. Once air has bled, close the Vent. Ensure the flow meter is registering proper flow and confirm the **BCF-OX** Relay is back in automatic operation ('OFF/ON').

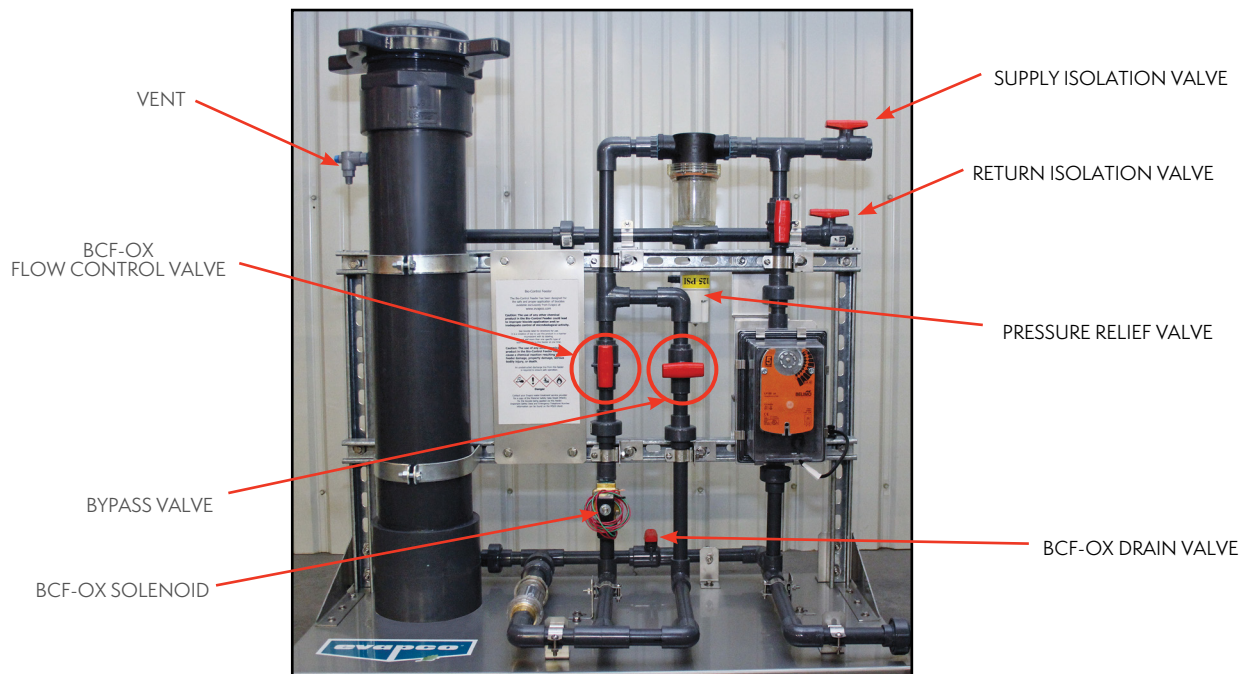

Figure 26 – Loading the **BCF-OX**



## 8.6 Replenishment Chemistry

The **BCF-OX-D** is available in two different sizes. The D15 can hold up to 15 lbs. (7 kg) and the D40 can hold up to 40 lbs. (20 kg) of oxidizing chemistry. Contact your EVAPCO Representative or Authorized Water Systems Provider for the type and amount of chemistry to be loaded into your system. Refer to the **BCF-OX** label and the biocide Material Safety Data Sheet (MSDS) prior to use. **CAUTION:** The use of any other chemical product in the **BCF-OX** could cause a chemical reaction resulting in feeder damage, property damage, serious bodily injury, or death.

## 8.7 Periodic Testing

Periodic testing by an EVAPCO Representative or Authorized Water Systems Service Provider must be performed to verify that the system is operating as designed and to adjust the feed timer duration or flow and chemistry amount based on changes in system load, ambient conditions, make-up water quality, or other local conditions.

# 9.0 Maintenance

Scheduled routine maintenance can help ensure that the Smart Shield® system operates at maximum efficiency and achieves a long service life. Maintaining a service agreement with an EVAPCO Representative or Authorized Water Systems Service Provider can help ensure that your system is properly monitored and serviced at regular intervals.

Some of the routine maintenance items that should be performed on the Smart Shield® are shown below in Figure 27.

Smart Shield® Component	Action Interval
Supply Strainer	Inspect weekly - clean as needed
BCF-OX Supply Strainer	Inspect weekly - clean as needed
Blow Down Valve	Confirm proper operation monthly
Flow Switch	Inspect monthly - clean as needed
Conductivity Probe	Clean monthly - calibrate as needed*
Chemistry Feeder Baskets	Inspect monthly - clean as needed
O-Rings	Inspect monthly - lubricate as needed**
Flow Meters	Confirm proper operation monthly

\*For specific calibration instructions, see controller IO&M.

\*\*Use only silicone based lubricant. DO NOT use any petroleum based product.

**Figure 27** – Routine Maintenance Items

## 10.0 Dry Lay-up and Shutdown

---

Proper lay-up and shutdown procedures should be utilized for all evaporative cooling equipment.

### 10.1 Dry Lay-up

EVAPCO's Smart Shield® for cooling towers and remote sump applications is designed to be located indoors, eliminating freeze concerns and the need for winterization. During periods of dry lay-up, no chemistry should be left in any feeders prior to the system being drained. Chemistry levels in all of the feeders should be managed in the months prior to dry lay-up to ensure minimal residual chemistry remains in the feeders during lay-up. While minimizing the chemistry level in all feeders is important, it is especially critically for the **BCF-NX**. The feed frequency and/or flow rate to the feeder can be increased to ensure no chemistry is left in the **BCF-NX** during dry lay-up.

### 10.2 Shutdown

Intermittent operation and/or stagnant water can cause operational problems. Circulation of the system water through the Smart Shield® several times per week is recommended for evaporative cooling equipment which is shut-down for short periods of time. If the evaporative cooling system is to be off-line for more than a few weeks, or circulation of the system water through the Smart Shield® every three days is not practical, the system should be drained and dry lay-up instructions should be followed (see Section 10.1).

## 11.0 Pre-cleaning and Passivation

---

All new evaporative cooling equipment and associated piping should be pre-cleaned and flushed for removal of grease, oil, dirt, debris and other suspended solids. Consult your evaporative cooling equipment's Instruction, Operation and Maintenance (IO&M) Manual for additional information regarding initial start-up and pre-cleaning.

All evaporative cooling equipment utilizing any galvanized materials of construction requires initial passivation to maximize the service life of the equipment. Consult your evaporative cooling equipment's Instruction, Operation and Maintenance (IO&M) Manual for additional information regarding passivation.

A site-specific pre-cleaning and/or passivation plan is not included with a Smart Shield® system. EVAPCO recommends that the site's water treatment vendor should be contacted several weeks prior to adding any water to a new evaporative cooling system to provide a pre-cleaning and/or passivation plan along with associated plan costs.

## 12.0 Legionella

---

*Legionella* bacteria are commonly present in natural and municipal water systems. Human exposure, and subsequent infection, depends on several concurrent factors. Drift that can emit from evaporative cooling equipment may provide a transmission mode of *Legionella* bacteria to humans. Human infection, however, is dependent on various factors such as the host's susceptibility, the level of contamination, and the virulence of the bacteria.

The biocides used as part of the Smart Shield® system have been shown to be effective against *Legionella* bacteria in laboratory testing. Even so, EVAPCO does not claim that using the Smart Shield® system will eliminate the presence of *Legionella* in water or control the potential risk factors for human infection.

There are many practices which may be effective in reducing the potential for *Legionella* infection. For more information, consult your local regulatory group and see ASHRAE Guideline 12-2020, "Minimizing the Risk of Legionellosis Associated with Building Water Systems".



## EVAPCO® STANDARD EXPRESS WARRANTY FOR SMART SHIELD® ONE YEAR TOTAL PRODUCT INCLUDING OPTIONS AND ACCESSORIES

### EXPRESS WARRANTY

EVAPCO warrants all components of the Smart Shield® Water Treatment System against failure caused by defects in materials and workmanship for a period of twelve (12) months from the date installation is completed in accordance with good engineering practices or eighteen (18) months from the date of shipment, whichever occurs first. Included in this warranty are the Inhibitor Feeder (CRF, FMF or MRF), Bio-Control Feeder(s), Conductivity Controller and Optional Equipment, if purchased as part of the Smart Shield® system, including conductivity probes, and motorized blowdown valves. All defective parts to be repaired or replaced shall be delivered to EVAPCO, shipping prepaid, with return shipment to the Buyer by EVAPCO to be made F.O.B. the factory, shipping prepaid by the Buyer.

**The product warranty is predicated on system operation and maintenance in accordance with EVAPCO's recommended operation and maintenance procedures. Failure to follow EVAPCO's recommended operation and maintenance procedures will void these warranties. Labor costs associated with any repair work performed under the terms of the warranties are NOT included within the warranty.**

The Buyer assumes responsibility for compliance with any regulations, codes, standards or ordinances applicable to the installation, location, operation or maintenance of the products. No person, agent, or dealer is authorized to enlarge upon the warranties set out herein or the obligations of EVAPCO hereunder.

### LIMITATION OF LIABILITY

THE SOLE REMEDY FOR BREACH OF THE EXPRESS WARRANTIES DESCRIBED HEREIN SHALL BE REPAIR OR REPLACEMENT OF THE EQUIPMENT BY EVAPCO, OR REFUNDING THE PURCHASE PRICE FOR THE SMART SHIELD WATER TREATMENT SYSTEM SET FORTH ON THE PURCHASE ORDER LESS STARTUP AND MONITORING FEES. IT SHALL BE IN EVAPCO'S SOLE DISCRETION AS TO WHETHER REPAIR, REPLACEMENT OR REFUND IS THE APPROPRIATE REMEDY. IF EVAPCO DECIDES TO MAKE REPAIRS, EVAPCO HAS THE OPTION OF COMPLETING ALL NECESSARY REPAIRS ITSELF, OR AUTHORIZING A THIRD PARTY TO PERFORM SUCH REPAIRS AT EVAPCO'S EXPENSE. EVAPCO IS NOT RESPONSIBLE FOR ANY REPAIR WORK PERFORMED BY A THIRD PARTY THAT EVAPCO DID NOT PRE-APPROVE IN WRITING. EVAPCO IS ONLY RESPONSIBLE FOR COSTS THAT PERTAIN TO REPAIR OR REPLACEMENT OF EQUIPMENT SUPPLIED BY EVAPCO (i.e., EVAPCO IS NOT RESPONSIBLE FOR REPLACEMENT OR MODIFICATION OF PIPING, OR "IN AND OUT" COSTS SUCH AS THIRD PARTY LABOR OR OTHER EQUIPMENT FEES).

NOTWITHSTANDING ANYTHING ELSE IN THIS DOCUMENT, EVAPCO'S LIABILITY OF ANY KIND WHATSOEVER SHALL NOT EXCEED THE PURCHASE PRICE SET FORTH ON THE PURCHASE ORDER. UNDER NO CIRCUMSTANCES SHALL EVAPCO BE LIABLE FOR LOST PROFITS, LOST SAVINGS, PERSONAL INJURIES, INCIDENTAL DAMAGES, ECONOMIC LOSS, PROPERTY DAMAGE, OR ANY OTHER CONSEQUENTIAL, INDIRECT, INCIDENTAL, OR PUNITIVE DAMAGES, EVEN IF EVAPCO HAS BEEN ADVISED OF THE POSSIBILITY OF SUCH DAMAGES INCLUDING WITHOUT LIMITATION ANY DAMAGES CAUSED TO THE COOLING OR REFRIGERATION SYSTEM AS A WHOLE OR ANY INDIVIDUAL COMPONENTS THEREOF. In addition, EVAPCO shall not be responsible for any injuries or damages of any kind whatsoever under any theory of tort to the extent the injuries or damage are caused by misuse of the product by buyer or any third party.

### DISCLAIMER OF IMPLIED WARRANTIES

OTHER THAN THE EXPRESS MANUFACTURER'S WARRANTY DESCRIBED HEREIN, THE UNIT IS SOLD "AS IS" AND THERE ARE NO OTHER WARRANTIES. EVAPCO HEREBY DISCLAIMS AND EXCLUDES ALL IMPLIED WARRANTIES OF ANY KIND WHATSOEVER, INCLUDING WITHOUT LIMITATION WARRANTIES OF MERCHANTABILITY, THAT THE UNIT IS FIT FOR A PARTICULAR USE OR PURPOSE, THAT THE UNIT IS FIT FOR A PARTICULAR APPLICATION OR ENVIRONMENT, AND ANY WARRANTIES THAT MIGHT OTHERWISE ARISE OUT OF A COURSE OF DEALING BETWEEN THE PARTIES OR USAGE OF TRADE.



**Contact your local EVAPCO Sales Representative or EVAPCO® Headquarters for more information.**



EVAPCO, Inc. **World Headquarters**  
5151 Allendale Lane  
Taneytown, MD 21787 USA  
Phone: 410-756-2600  
E-mail: [marketing@evapco.com](mailto:marketing@evapco.com)

EVAPCO Europe BV  
**European Headquarters**  
Industrieterrein Oost 4010  
3700 Tongeren, Belgium  
Phone: (32) 12-395029  
E-mail: [evapco.europe@evapco.be](mailto:evapco.europe@evapco.be)

EVAPCO Asia/Pacific **Headquarters**  
1159 Luoning Rd., Baoshan Industrial Zone  
Shanghai, P.R. China, Postal Code: 200949  
Phone: (86) 21-6687-7786  
E-mail: [marketing@evapcochina.com](mailto:marketing@evapcochina.com)

Visit EVAPCO's Website: [www.evapco.com](http://www.evapco.com)

©2024 EVAPCO, Inc.  
All Rights Reserved

