

UNIT CLOSED CIRCUIT COOLER  
 MODEL # ESW4 14-45Q22-AP SCALE NTS

# EVAPCO, INC.

DWG. # WX414224810-DRB-ST REV -  
 SERIAL # DATE: 4/29/2026

- NOTES:
- (M)- FAN MOTOR LOCATION
  - HEAVIEST SECTION IS COIL SECTION
  - MPT DENOTES MALE PIPE THREAD  
 FPT DENOTES FEMALE PIPE THREAD  
 BFW DENOTES BEVELED FOR WELDING  
 GVD DENOTES GROOVED  
 FLG DENOTES FLANGE
  - +UNIT WEIGHT DOES NOT INCLUDE ACCESSORIES (SEE ACCESSORY DRAWINGS)
  - 3/4" [19MM] DIA. MOUNTING HOLES. REFER TO RECOMMENDED STEEL SUPPORT DRAWING
  - MAKE-UP WATER PRESSURE  
 20 psi MIN [137 kPa], 50 psi MAX [344 kPa]
  - DIMENSIONS LISTED AS FOLLOWS:  
 ENGLISH FT-IN  
 [METRIC] [mm]
  - \* - APPROXIMATE DIMENSIONS DO NOT USE FOR PRE-FABRICATION OF CONNECTING PIPING

**FACE B  
 PLAN VIEW**

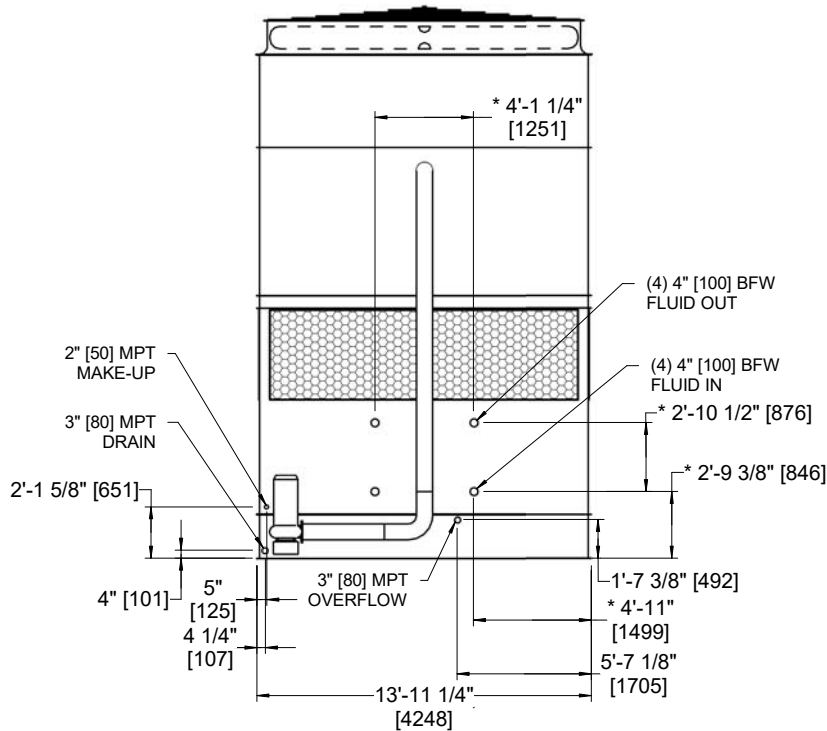

**FACE B**

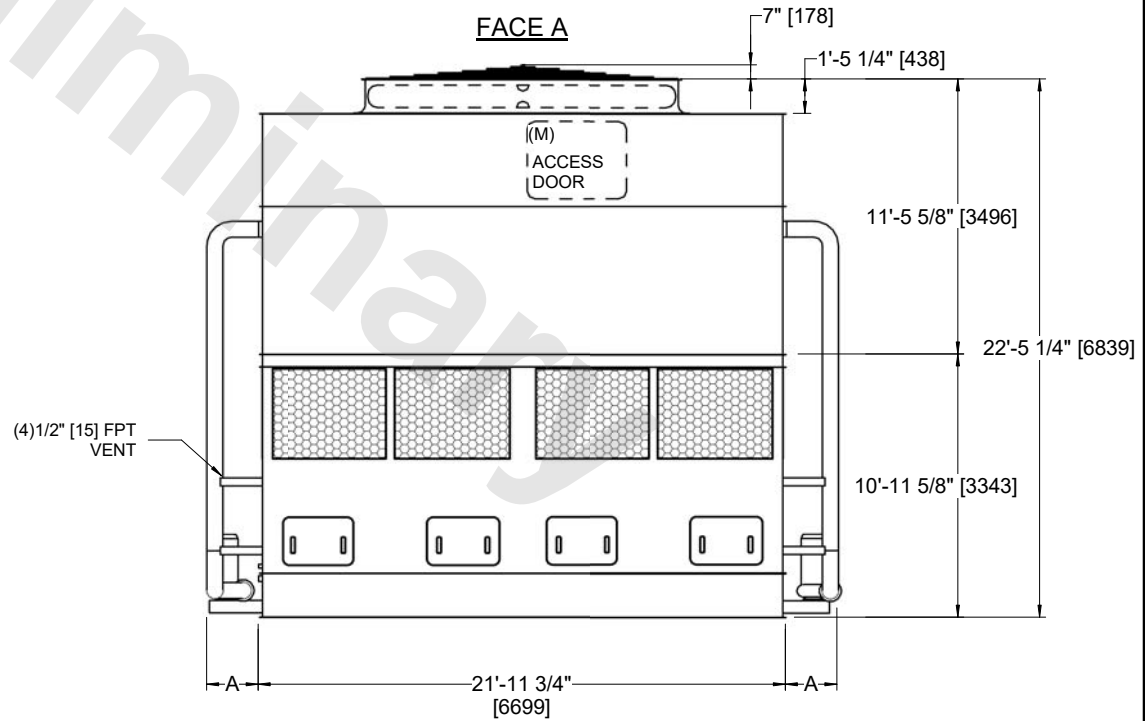

**FACE A**

MODEL NUMBER	DIMENSION A
ESW4 14-45*22-LP	2'-1 3/4"
ESW4 14-45*22-AP	2'-7 1/4"

SHIPPING WEIGHT 44570 lbs+ [20220] kg+

OPERATING WEIGHT 65190 lbs+ [29570] kg+

HEAVIEST SECTION WEIGHT 30410 lbs+ [13795] kg+

NO. OF SHIPPING SECTIONS 2

DRAWN BY: JLG