

| | |
|---------|-----------------------|
| UNIT | CLOSED CIRCUIT COOLER |
| MODEL # | ESW4 14-53L22-AP |
| SCALE | NTS |

EVAPCO, INC.

| | | | |
|----------|--------------------|-------|----------|
| DWG. # | WX414226006-DRB-ST | REV | - |
| SERIAL # | | DATE: | 5/1/2026 |

NOTES:

- (M)- FAN MOTOR LOCATION
- HEAVIEST SECTION IS COIL SECTION
- MPT DENOTES MALE PIPE THREAD
FPT DENOTES FEMALE PIPE THREAD
BFW DENOTES BEVELED FOR WELDING
GVD DENOTES GROOVED
FLG DENOTES FLANGE
- +UNIT WEIGHT DOES NOT INCLUDE ACCESSORIES (SEE ACCESSORY DRAWINGS)
- 3/4" [19MM] DIA. MOUNTING HOLES. REFER TO RECOMMENDED STEEL SUPPORT DRAWING
- MAKE-UP WATER PRESSURE
20 psi MIN [137 kPa], 50 psi MAX [344 kPa]
- DIMENSIONS LISTED AS FOLLOWS:
ENGLISH FT-IN
[METRIC] [mm]
- * - APPROXIMATE DIMENSIONS DO NOT USE FOR PRE-FABRICATION OF CONNECTING PIPING

FACE C

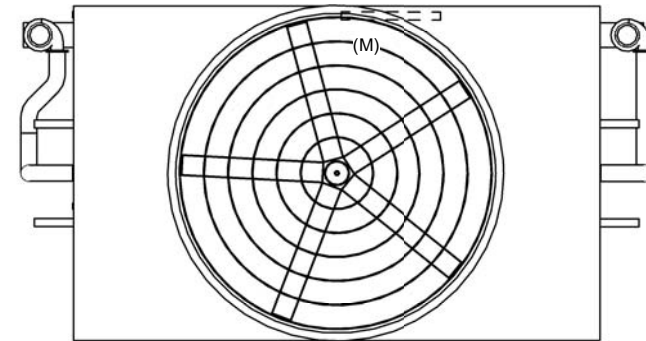

**FACE B
PLAN VIEW**

FACE D

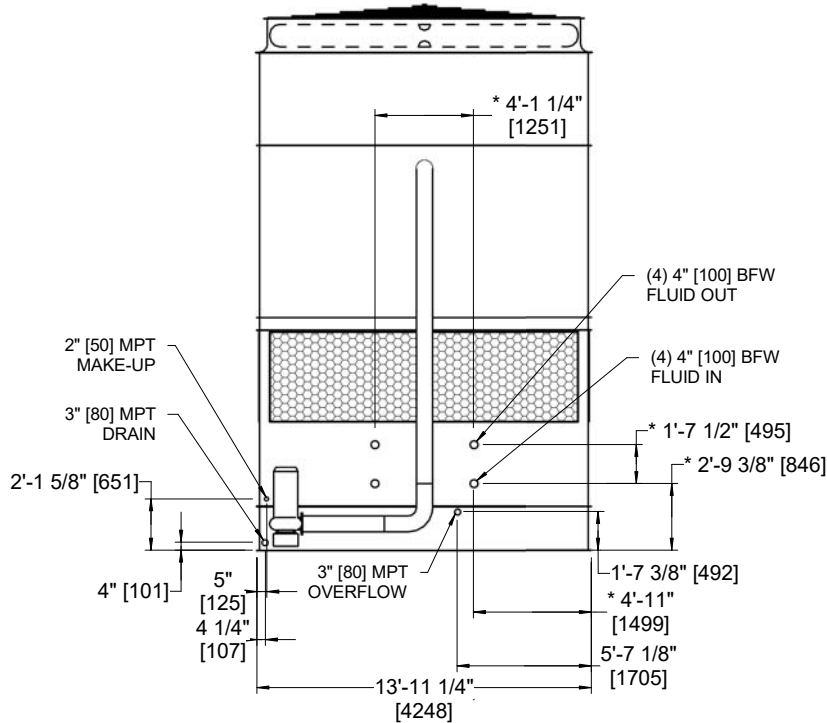

FACE B

FACE A

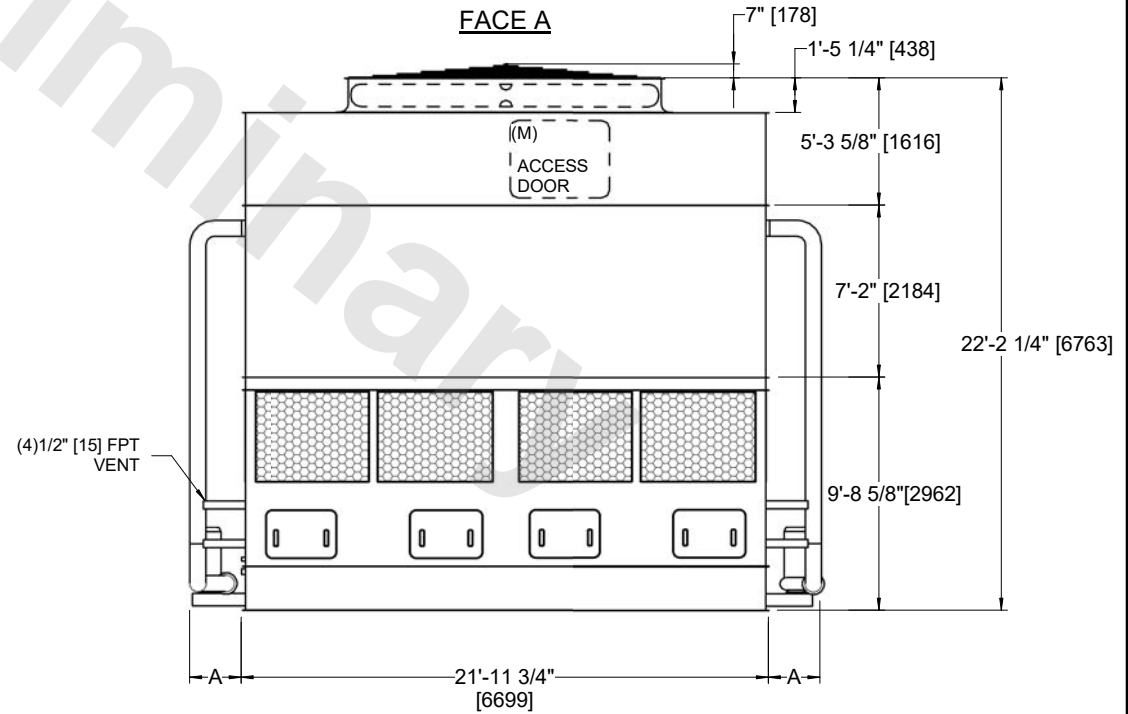

FACE A

| MODEL NUMBER | DIMENSION A |
|------------------|-------------|
| ESW4 14-53*22-LP | 2'-1 3/4" |
| ESW4 14-53*22-AP | 2'-7 1/4" |

| | | | | | | | | | |
|-----------------|------------------------|------------------|------------------------|-------------------------|------------------------|--------------------------|---|-----------|-----|
| SHIPPING WEIGHT | 38540 lbs+ [17485] kg+ | OPERATING WEIGHT | 55050 lbs+ [24975] kg+ | HEAVIEST SECTION WEIGHT | 22990 lbs+ [10430] kg+ | NO. OF SHIPPING SECTIONS | 3 | DRAWN BY: | JLG |
|-----------------|------------------------|------------------|------------------------|-------------------------|------------------------|--------------------------|---|-----------|-----|