

CONFIDENTIAL

This document is the property of Evapco, Inc. It should not be copied or disclosed without prior written authorization.

| | | | | | |
|----------|---------------------------------|--------------|---------------------|--------|----------------|
| CUSTOMER | MODEL # U-SSTWE2-19R64F0100F1LA | SCALE N.T.S. | DWG. # USSTW2-SE-6L | REV. 0 | DATE 5/16/2026 |
|----------|---------------------------------|--------------|---------------------|--------|----------------|

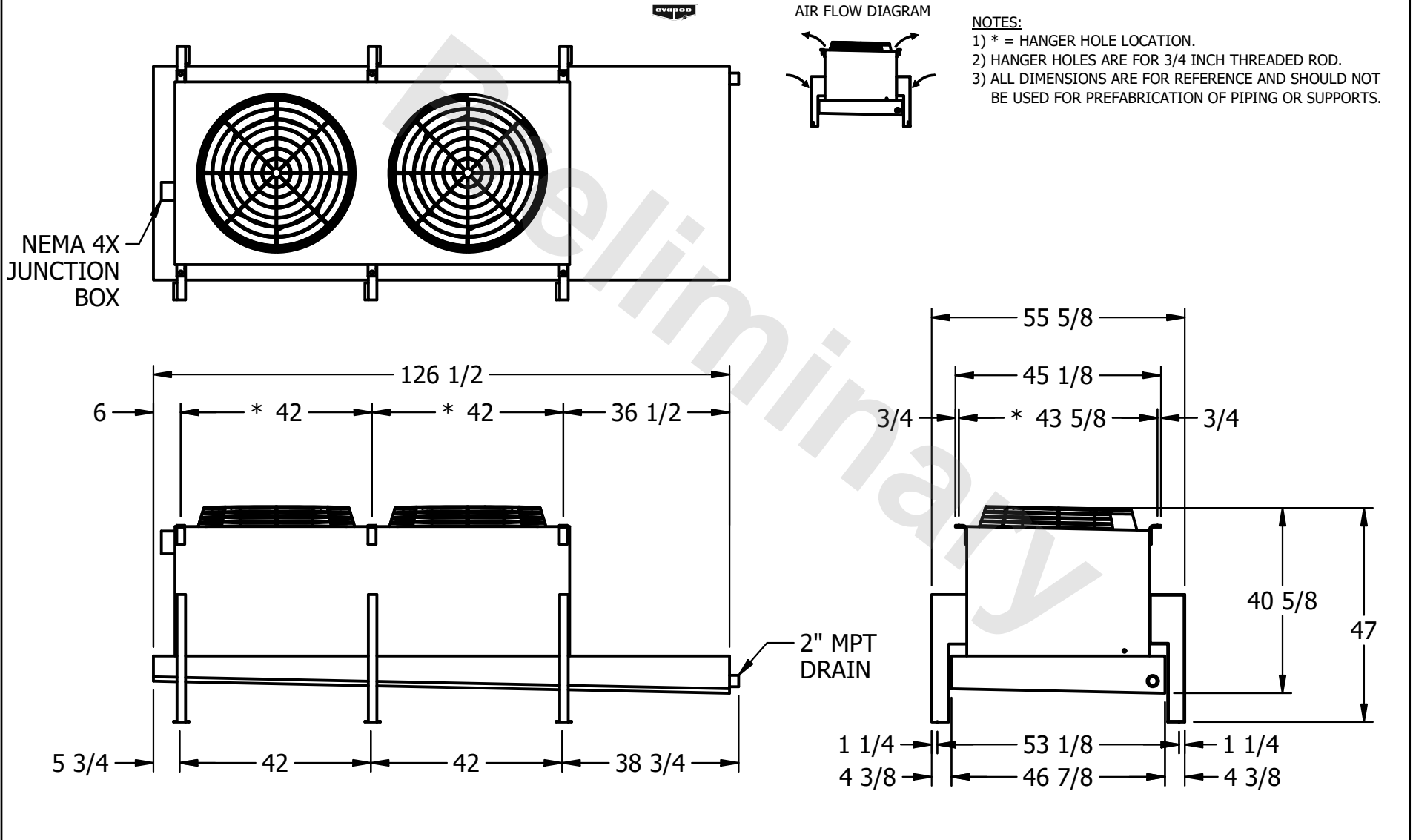

| | | | |
|---------|------|------------------------------------|--------------------------------------|
| PROJECT | ROOM | SHIPPING WEIGHT 990 lbs+ [450] kg+ | OPERATING WEIGHT 1130 lbs+ [515] kg+ |
|---------|------|------------------------------------|--------------------------------------|