

**CONFIDENTIAL**

This document is the property of Evapco, Inc. It should not be copied or disclosed without prior written authorization.

CUSTOMER	MODEL # U-SSTWE2-19R63H0100F1KA	SCALE N.T.S.	DWG. # USSTW2-SE-6L	REV. 0	DATE 7/7/2025
----------	---------------------------------	--------------	---------------------	--------	---------------

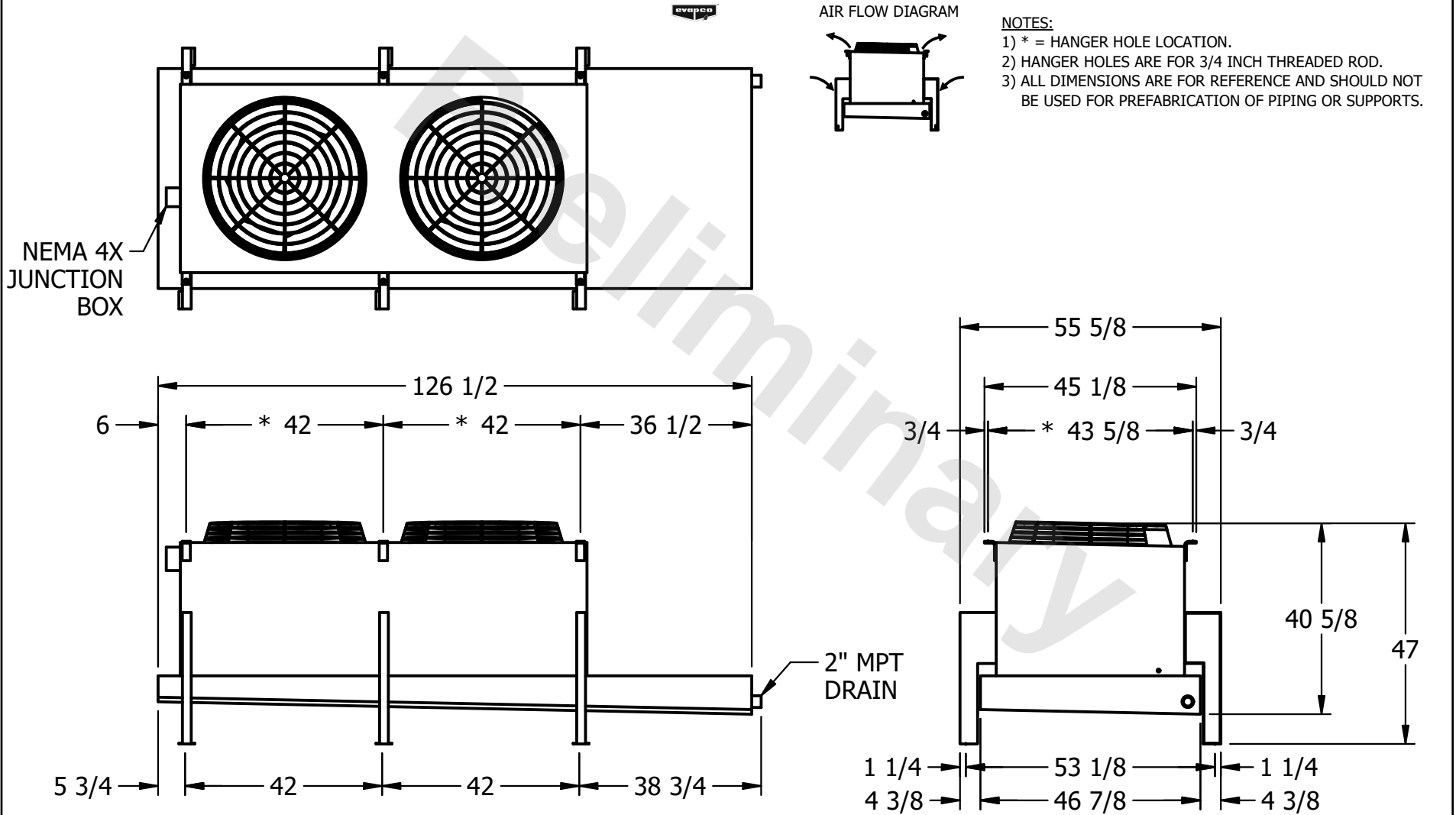

PROJECT	ROOM	SHIPPING WEIGHT 1100 lbs+ [500] kg+	OPERATING WEIGHT 1210 lbs+ [550] kg+
---------	------	-------------------------------------	--------------------------------------