

EVAPCO, INC.

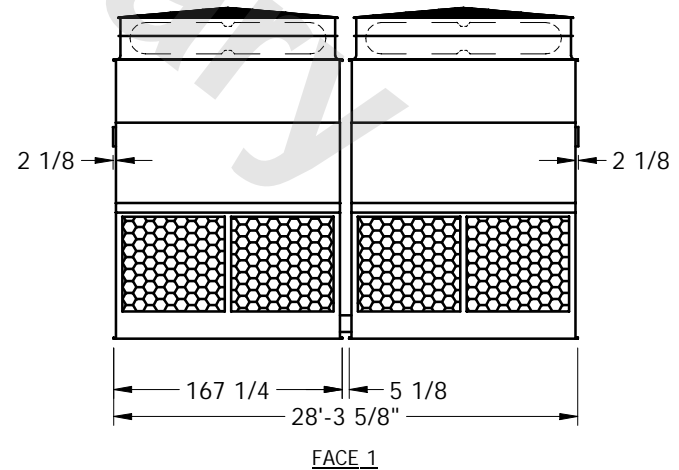

UNIT	COOLING TOWER	MODEL #	MTT 310-3K30	SCALE	NTS	DWG. #	T2282448-ERB-SRL	REV.		DATE	4/3/2026	SERIAL #	
------	---------------	---------	--------------	-------	-----	--------	------------------	------	--	------	----------	----------	--

- NOTES:
- (M) FAN MOTOR LOCATION
 - HEAVIEST SECTION IS UPPER SECTION
 - MPT DENOTES MALE PIPE THREAD
FPT DENOTES FEMALE PIPE THREAD
BFW DENOTES BEVELED FOR WELDING
 - + UNIT WEIGHT DOES NOT INCLUDE ACCESSORIES (SEE SEPARATE DRAWINGS FOR ACCESSORIES)
 - 3/4" DIA. MOUNTING HOLES. REFER TO RECOMMENDED STEEL SUPPORT DRAWING

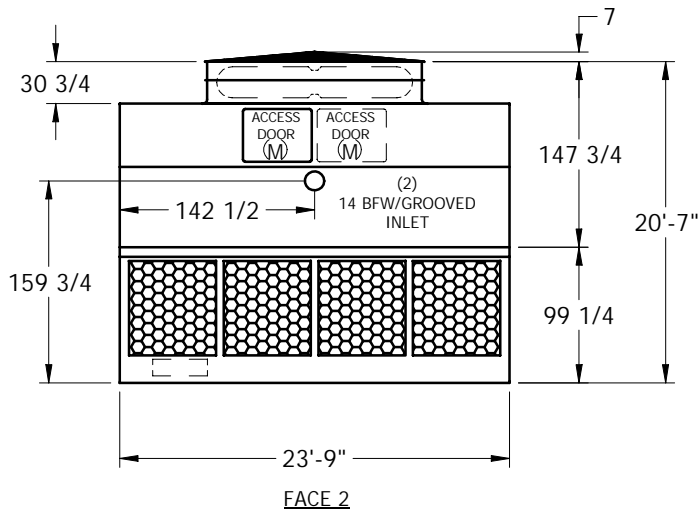
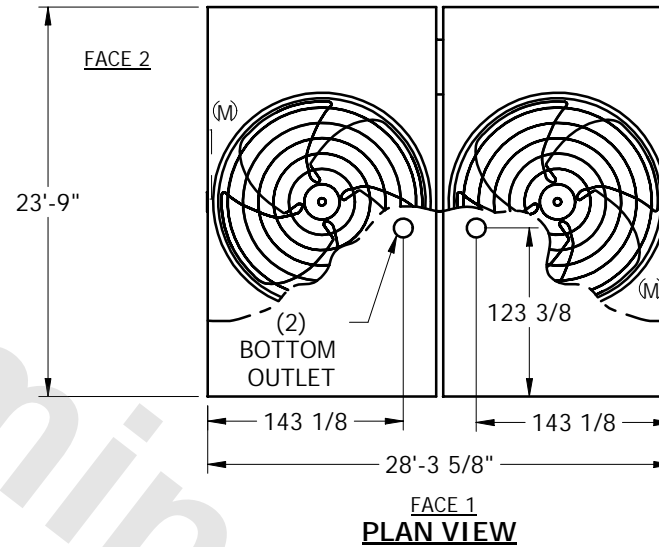

SHIPPING WEIGHT	40940	lbs. +	OPERATING WEIGHT	52940	lbs.	HEAVIEST SECTION WEIGHT	14910	lbs.	NO. OF SHIPPING SECTIONS	4
-----------------	-------	--------	------------------	-------	------	-------------------------	-------	------	--------------------------	---