

## SLOPED LADDER EXTENSIONS

DWG. # LDW20921MB-XT

### NOTES:

1. LADDER AND BRACKETS SHIP LOOSE. FIELD INSTALLATION BY OTHERS IS REQUIRED.
2. REFER TO RIGGING PACK FOR LADDER AND PLATFORM MOUNTING INSTRUCTIONS.
3. RIG LADDER BEFORE INSTALLING PIPEWORK TO UNIT.

LADDER W/BRACKET ASSEMBLY WILL SHIP LOOSE FOR FIELD MOUNTING BY OTHERS.

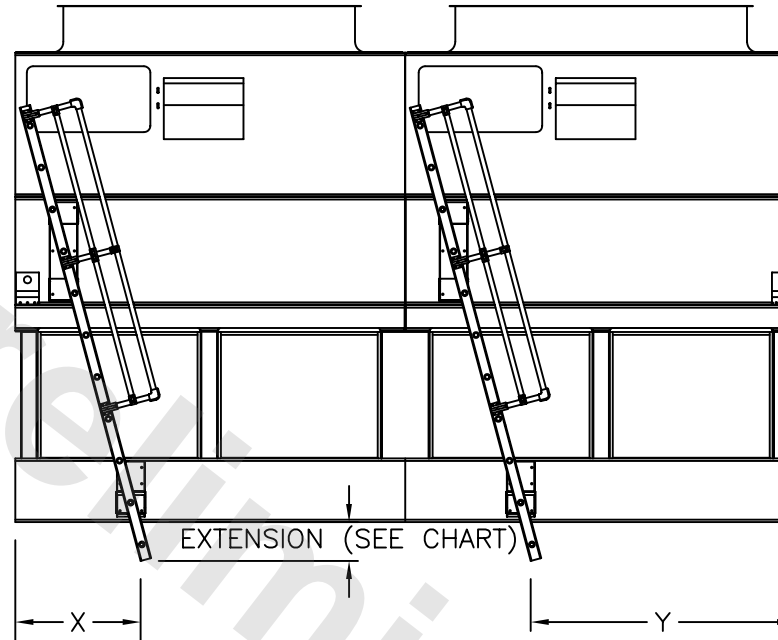

SIDE VIEW

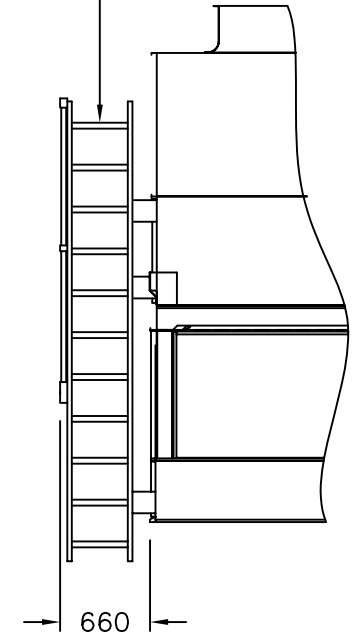

END VIEW

MODEL NUMBER		305mm EXTENSION		610mm EXTENSION		914mm EXTENSION	
COOLER	CONDENSER	'X'	'Y'	'X'	'Y'	'X'	'Y'
ATW 179-3I,3J	ATC 508B	1089	2111	1172	2029	1254	1946
ATW 179-4I,4J	ATC 557B,609B	1105	2096	1187	2013	1270	1930
ATW 179-5J,5K	ATC 666B,703B	1178	2022	1260	1940	1343	1857
ATW 179-6K,6L	ATC 687B,725B,755B	1232	1962	1315	1880	1397	1797

### CUSTOMER INSTALLATION NOTES:

- a. REMOVE LADDER BRACKET MOUNTING BOLTS (1) FROM LADDER MOUNTING CHANNELS (2) ON PAN AND CASING SECTIONS.
- b. LOOSEN, BUT DO NOT REMOVE, LADDER BRACKET AND ASSY. BOLTS (3).
- c. TO ASSEMBLE, SLIDE LADDER BRACKET ASSY. (4) OVER LADDER MOUNTING CHANNELS (2) LOCATED ON PAN AND CASING (DO NOT REMOVE LADDER BRACKET ASSY. (4) FROM LADDER.)
- d. ALIGN HOLES AND REINSTALL LADDER BRACKET MOUNTING BOLTS (1) THROUGH LADDER BRACKET ASSY. (4) AND LADDER MOUNTING CHANNELS (2).
- e. TIGHTEN ALL BOLTS.
- f. TIGHTEN ADJUSTING SCREW (5) IN THE ADJUSTABLE MOUNTING BRACKETS WHEN APPLICABLE.

