

EVAPCO, INC.



UNIT	CLOSED CIRCUIT COOLER	MODEL #	eco-ATC-1001A	SCALE	NTS	DWG. #	WZ09094810-ERA-SR	REV.	DATE	SERIAL #
------	------------------------------	---------	---------------	-------	-----	--------	-------------------	------	------	----------

- NOTES:
1. (M) - FAN MOTOR LOCATION
 2. HEAVIEST SECTION IS LOWER SECTION
 3. MPT DENOTES MALE PIPE THREAD
FPT DENOTES FEMALE PIPE THREAD
BFW DENOTES BEVELED FOR WELDING
 4. † UNIT WEIGHT DOES NOT INCLUDE ACCESSORIES (SEE SEPARATE DRAWINGS FOR ACCESSORIES)
 5. 3/4" DIA. MOUNTING HOLES. REFER TO RECOMMENDED STEEL SUPPORT DRAWING
 6. THE SPRAY PUMP SHOULD BE SIZED FOR 650 GPM AND 4 PSIG AT THE INLET CONNECTION
 7. * - APPROXIMATE DIMENSIONS DO NOT USE FOR PRE-FABRICATION OF CONNECTING PIPING
 8. SERIES FLOW CROSSOVER PIPING PROVIDED INTERNALLY

**FACE 2
PLAN VIEW**

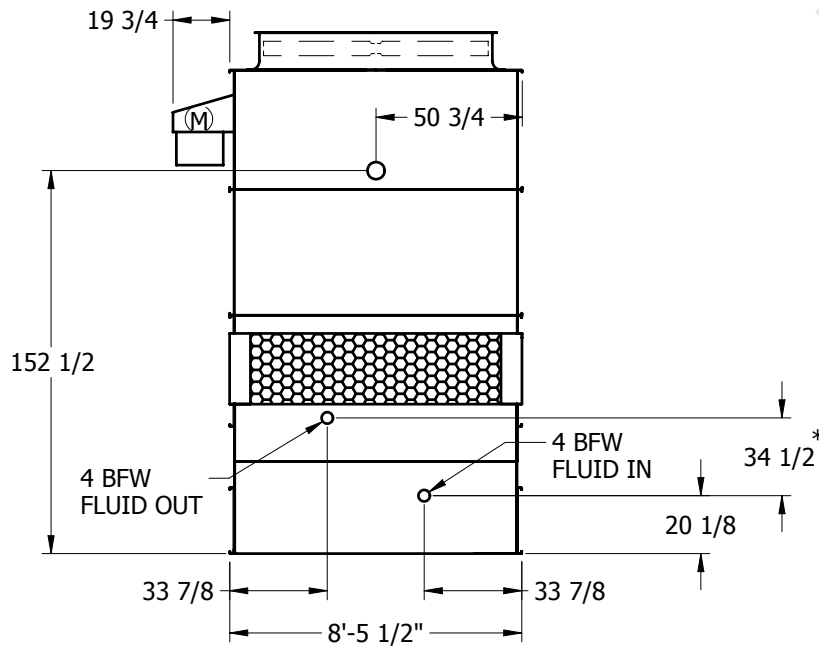
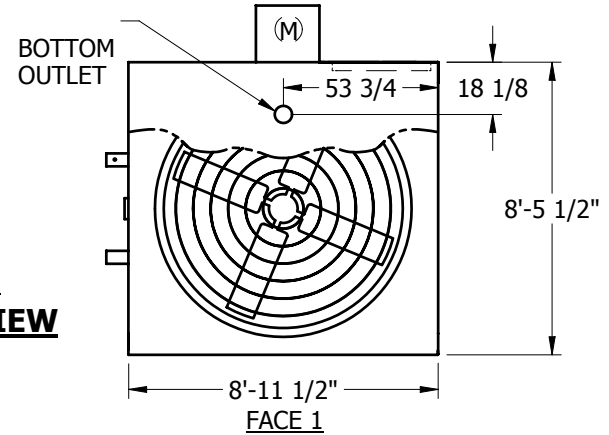

FACE 2

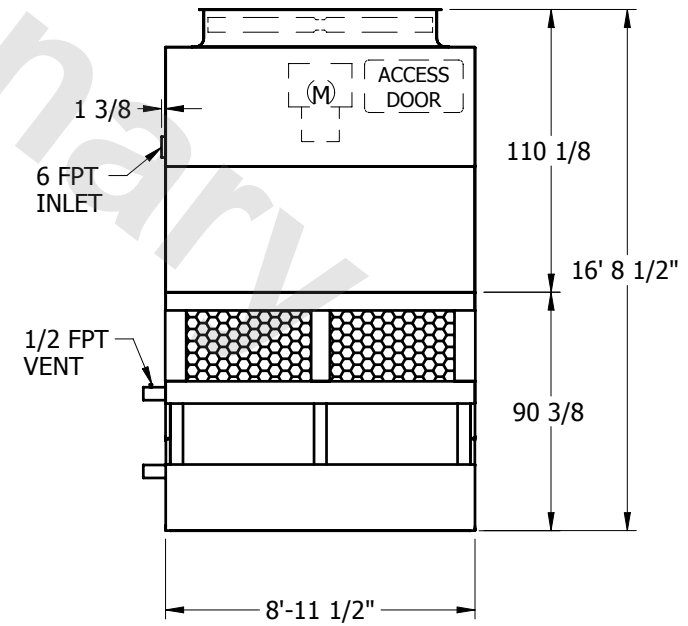

FACE 1

SHIPPING WEIGHT	9750	lbs. †	OPERATING WEIGHT	12390	lbs.	HEAVIEST SECTION WEIGHT	6370	lbs.	NO. OF SHIPPING SECTIONS	2
-----------------	------	--------	------------------	-------	------	-------------------------	------	------	--------------------------	---