

EVAPCO, INC.

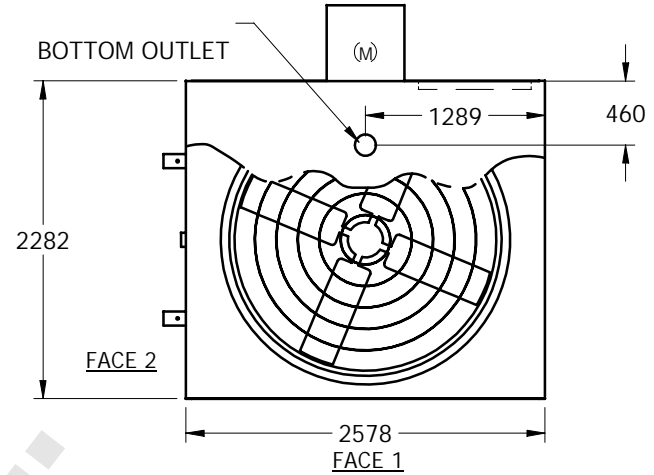

UNIT	CLOSED CIRCUIT COOLER	MODEL #	eco-ATC-1001A	SCALE	NTS	DWG. #	W2090806-MRC-RS	REV.	DATE	SERIAL #
------	------------------------------	---------	---------------	-------	-----	--------	-----------------	------	------	----------

- NOTES:
- (M)- FAN MOTOR LOCATION
 - HEAVIEST SECTION IS UPPER SECTION
 - MPT DENOTES MALE PIPE THREAD
FPT DENOTES FEMALE PIPE THREAD
BFW DENOTES BEVELED FOR WELDING
 - + UNIT WEIGHT DOES NOT INCLUDE ACCESSORIES (SEE SEPARATE DRAWINGS FOR ACCESSORIES)
 - 19mm DIA. MOUNTING HOLES. REFER TO RECOMMENDED STEEL SUPPORT DRAWING
 - THE SPRAY PUMP SHOULD BE SIZED FOR 21 L/S AND 17 kPa AT THE INLET CONNECTION
 - *- APPROXIMATE DIMENSIONS DO NOT USE FOR PRE-FABRICATION OF CONNECTING PIPING



PLAN VIEW

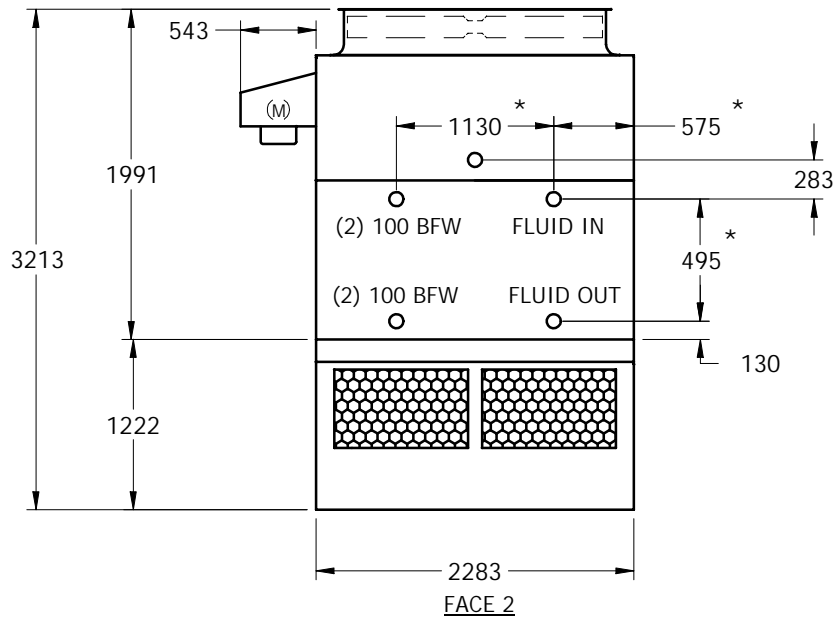

FACE 2

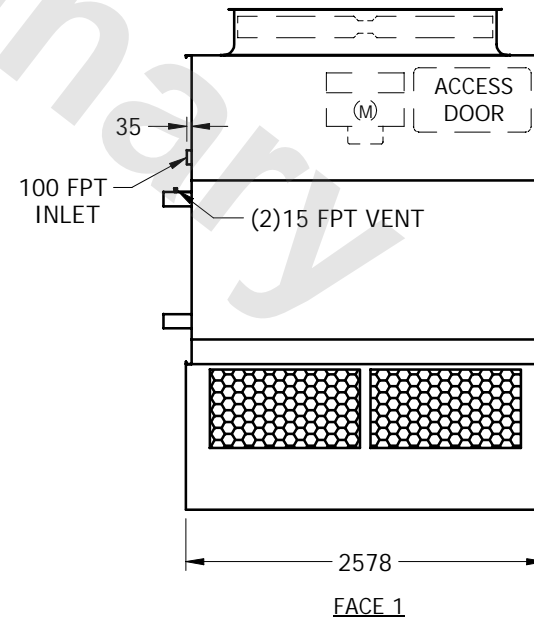

FACE 1

SHIPPING WEIGHT	3275	kg +	OPERATING WEIGHT	4325	kg	HEAVIEST SECTION WEIGHT	2685	kg	NO. OF SHIPPING SECTIONS	2
-----------------	------	------	------------------	------	----	-------------------------	------	----	--------------------------	---