

EVAPCO, INC.



UNIT	CLOSED CIRCUIT COOLER	MODEL #	eco-ATC-2696A	SCALE	NTS	DWG. #	WZ09094808-MRA-SLHR	REV.		DATE	5/11/2026	SERIAL #	
------	------------------------------	---------	---------------	-------	-----	--------	---------------------	------	--	------	-----------	----------	--

- NOTES:
1. (M) - FAN MOTOR LOCATION
 2. HEAVIEST SECTION IS LOWER SECTION
 3. MPT DENOTES MALE PIPE THREAD
FPT DENOTES FEMALE PIPE THREAD
BFW DENOTES BEVELED FOR WELDING
 4. † UNIT WEIGHT DOES NOT INCLUDE ACCESSORIES (SEE SEPARATE DRAWINGS FOR ACCESSORIES)
 5. 19mm DIA. MOUNTING HOLES. REFER TO RECOMMENDED STEEL SUPPORT DRAWING
 6. THE SPRAY PUMP SHOULD BE SIZED FOR 41 L/S AND 28 kPa AT THE INLET CONNECTION
 7. * - APPROXIMATE DIMENSIONS DO NOT USE FOR PRE-FABRICATION OF CONNECTING PIPING

**FACE 2
PLAN VIEW**

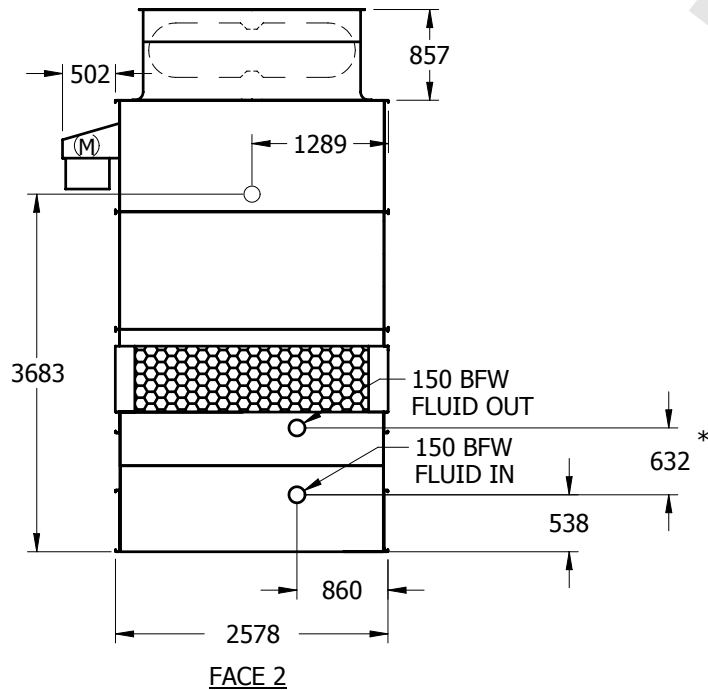
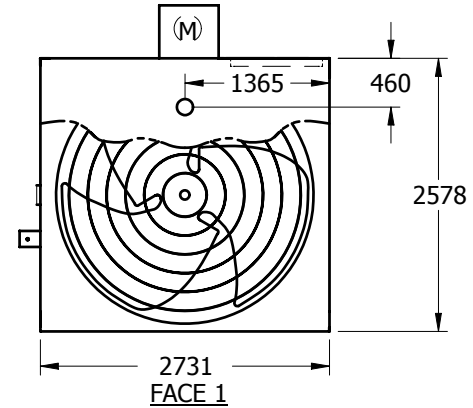

FACE 2

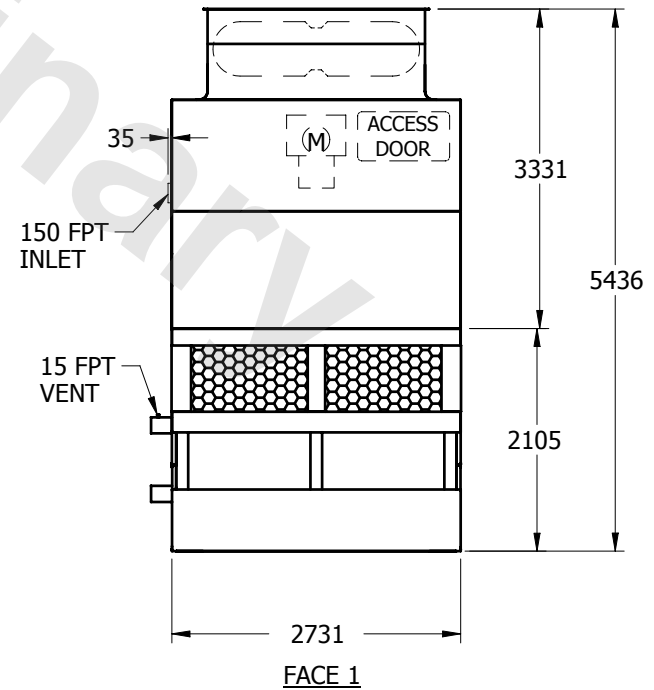

FACE 1

SHIPPING WEIGHT	4155	kg	+	OPERATING WEIGHT	5230	kg	HEAVIEST SECTION WEIGHT	2535	kg	NO. OF SHIPPING SECTIONS	2
-----------------	------	----	---	------------------	------	----	-------------------------	------	----	--------------------------	---