

EVAPCO, INC.

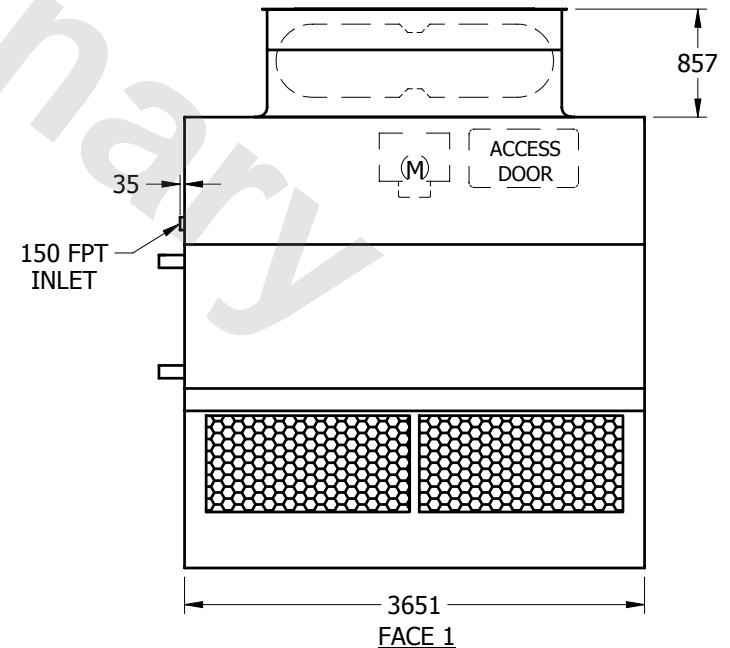

UNIT	EVAPORATIVE CONDENSER	MODEL #	ATWB 7-5J24	SCALE	NTS	DWG. #	C2091210-MRA-SRL	REV.		DATE	5/18/2026	SERIAL #	
-------------	------------------------------	----------------	-------------	--------------	-----	---------------	------------------	-------------	--	-------------	-----------	-----------------	--

- NOTES:
- (M)- FAN MOTOR LOCATION
 - HEAVIEST SECTION IS UPPER SECTION
 - MPT DENOTES MALE PIPE THREAD
FPT DENOTES FEMALE PIPE THREAD
BFW DENOTES BEVELED FOR WELDING
 - + UNIT WEIGHT DOES NOT INCLUDE ACCESSORIES (SEE SEPARATE DRAWINGS FOR ACCESSORIES)
 - 19mm DIA. MOUNTING HOLES. REFER TO RECOMMENDED STEEL SUPPORT DRAWING
 - THE SPRAY PUMP SHOULD BE SIZED FOR 35 L/S AND 17 kPa AT THE INLET CONNECTION
 - *- APPROXIMATE DIMENSIONS DO NOT USE FOR PRE-FABRICATION OF CONNECTING PIPING

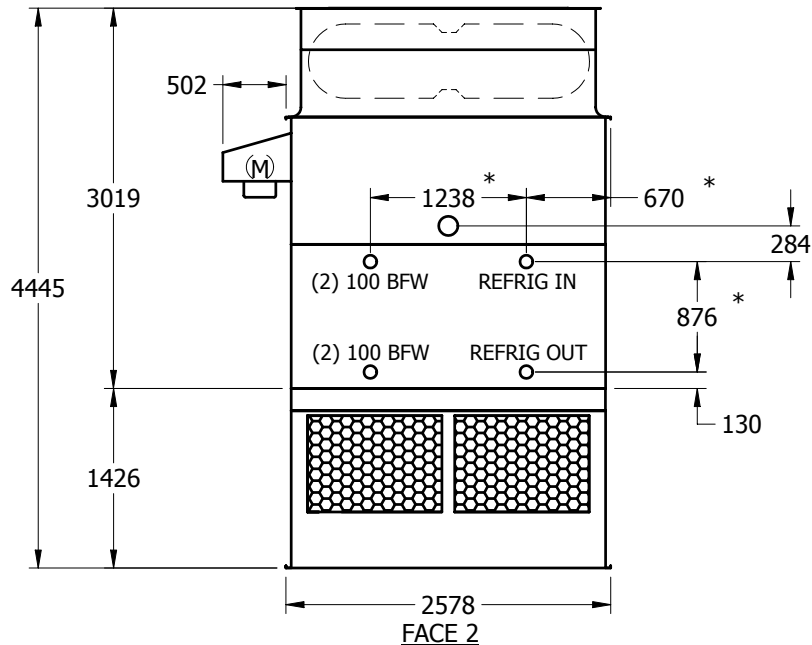
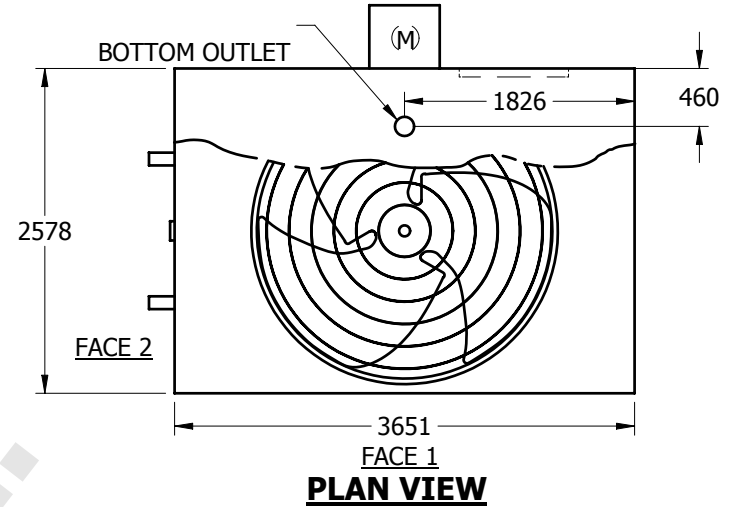

SHIPPING WEIGHT	6385	kg +	OPERATING WEIGHT	7675	kg	HEAVIEST SECTION WEIGHT	5560	kg	NO. OF SHIPPING SECTIONS	2
------------------------	------	-------------	-------------------------	------	-----------	--------------------------------	------	-----------	---------------------------------	---