

EVAPCO, INC.

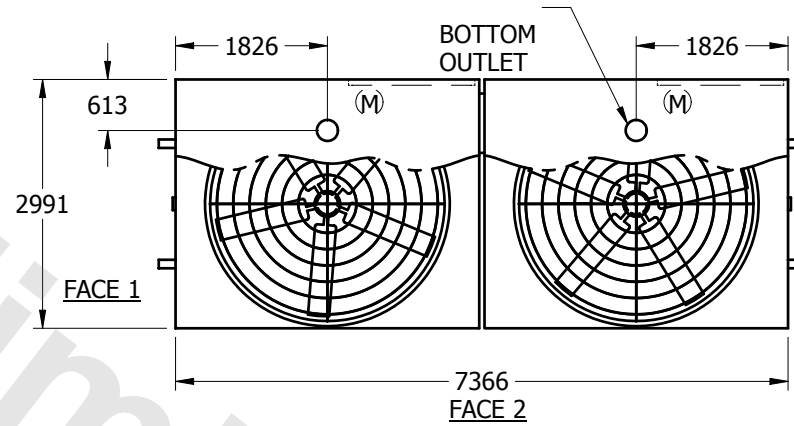

UNIT	EVAPORATIVE CONDENSER	MODEL #	ESW4 12-23L12-LP	SCALE	NTS	DWG. #	C2TM2412-MRA-RS	REV.		DATE	5/18/2026	SERIAL #	
-------------	------------------------------	----------------	------------------	--------------	-----	---------------	-----------------	-------------	--	-------------	-----------	-----------------	--

- NOTES:
- (M)- FAN MOTOR LOCATION
 - HEAVIEST SECTION IS UPPER SECTION
 - MPT DENOTES MALE PIPE THREAD
FPT DENOTES FEMALE PIPE THREAD
BFW DENOTES BEVELED FOR WELDING
 - + UNIT WEIGHT DOES NOT INCLUDE ACCESSORIES (SEE SEPARATE DRAWINGS FOR ACCESSORIES)
 - 19mm DIA. MOUNTING HOLES. REFER TO RECOMMENDED STEEL SUPPORT DRAWING
 - THE SPRAY PUMP SHOULD BE SIZED FOR 86 L/S AND 28 kPa AT THE INLET CONNECTION
 - *- APPROXIMATE DIMENSIONS DO NOT USE FOR PRE-FABRICATION OF CONNECTING PIPING



PLAN VIEW

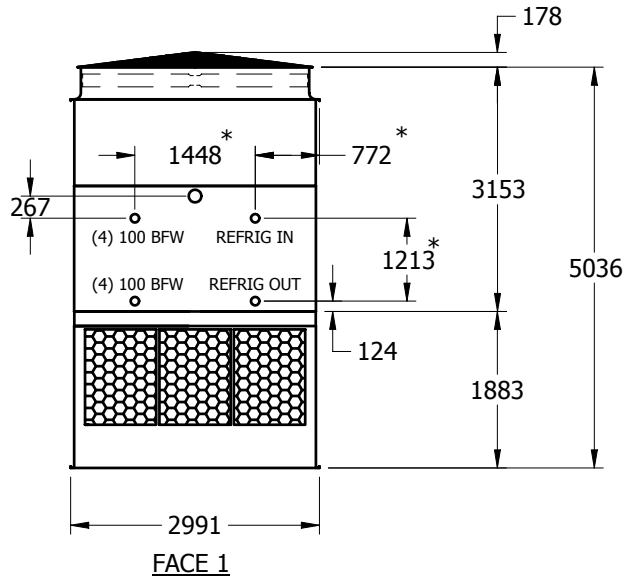

FACE 1

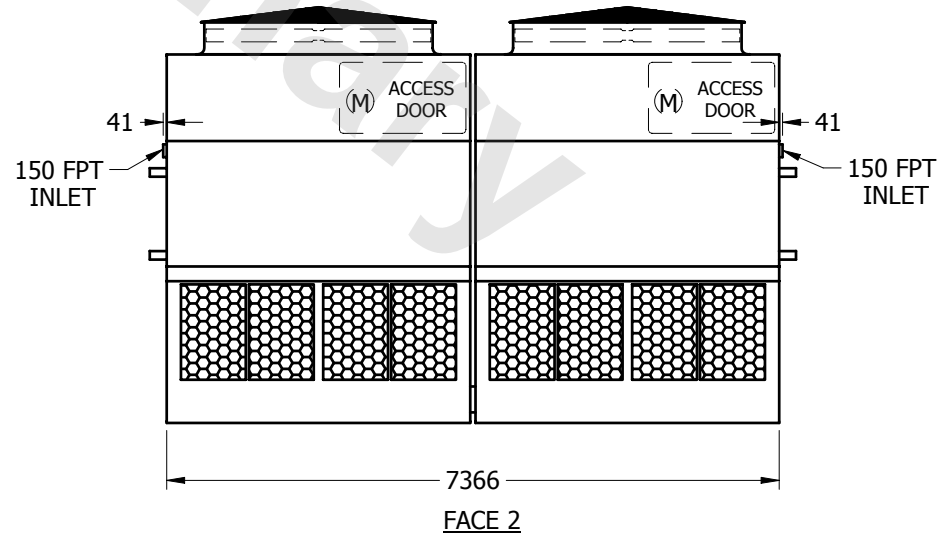

FACE 2

SHIPPING WEIGHT	16445	kg +	OPERATING WEIGHT	18975	kg	HEAVIEST SECTION WEIGHT	7045	kg	NO. OF SHIPPING SECTIONS	4
------------------------	-------	-------------	-------------------------	-------	-----------	--------------------------------	------	-----------	---------------------------------	---