

EVAPCO, INC.

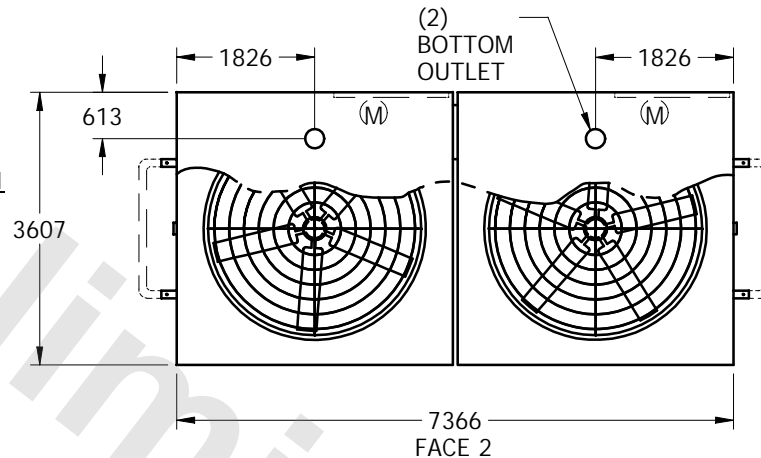

| | | | | | | | | | | | | | |
|------|-----------------------|---------|----------|-------|-----|--------|-----------------|------|--|------|-----------|----------|--|
| UNIT | CLOSED CIRCUIT COOLER | MODEL # | CATC-181 | SCALE | NTS | DWG. # | W2122412-MRD-SR | REV. | | DATE | 5/21/2026 | SERIAL # | |
|------|-----------------------|---------|----------|-------|-----|--------|-----------------|------|--|------|-----------|----------|--|

- NOTES:
- (M)- FAN MOTOR LOCATION
 - HEAVIEST SECTION IS UPPER SECTION
 - MPT DENOTES MALE PIPE THREAD
FPT DENOTES FEMALE PIPE THREAD
BFW DENOTES BEVELED FOR WELDING
 - + UNIT WEIGHT DOES NOT INCLUDE ACCESSORIES (SEE SEPARATE DRAWINGS FOR ACCESSORIES)
 - 19mm DIA. MOUNTING HOLES. REFER TO RECOMMENDED STEEL SUPPORT DRAWING
 - THE SPRAY PUMP SHOULD BE SIZED FOR 101 L/S AND 17 kPa AT THE INLET CONNECTION
 - *- APPROXIMATE DIMENSIONS DO NOT USE FOR PRE-FABRICATION OF CONNECTING PIPING
 - SERIES FLOW PIPING AND AUX. CROSSOVER DRAIN BY OTHERS



PLAN VIEW

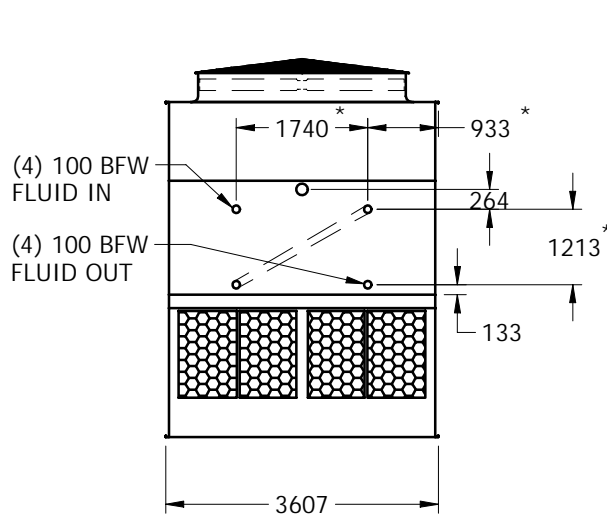

FACE 1

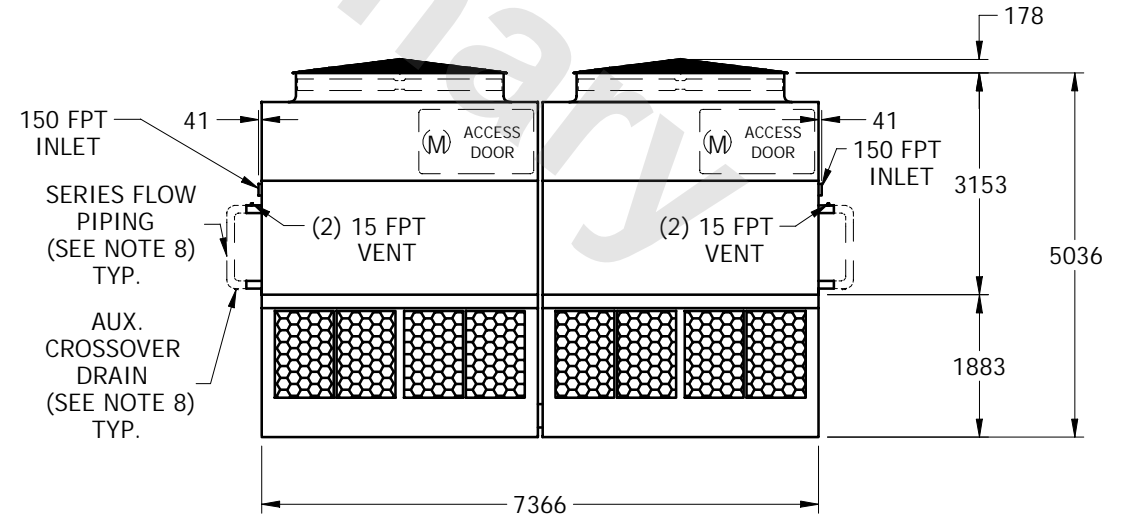

FACE 2

| | | | | | | | | | | |
|-----------------|-------|------|------------------|-------|----|-------------------------|------|----|--------------------------|---|
| SHIPPING WEIGHT | 20575 | kg + | OPERATING WEIGHT | 27515 | kg | HEAVIEST SECTION WEIGHT | 9130 | kg | NO. OF SHIPPING SECTIONS | 4 |
|-----------------|-------|------|------------------|-------|----|-------------------------|------|----|--------------------------|---|