

EVAPCO, INC.



| | | | | | | |
|-------------------------------|--------------------------------|-----------------|-----------------------------|-----------|-------------------|----------|
| UNIT EVAPORATIVE CONDENSER | MODEL # ATC-DC-2012K-25-2EF | SCALE N.T.S. | DWG. # EGCH6M1204-DRA-ST | REV. - | DATE 6/21/2026 | SERIAL # |
|-------------------------------|--------------------------------|-----------------|-----------------------------|-----------|-------------------|----------|

- NOTES:
- (M)- FAN MOTOR LOCATION
 - HEAVIEST SECTION IS COIL SECTION
 - MPT DENOTES MALE PIPE THREAD
FPT DENOTES FEMALE PIPE THREAD
BFW DENOTES BEVELED FOR WELDING
 - +UNIT WEIGHT DOES NOT INCLUDE ACCESSORIES (SEE ACCESSORY DRAWINGS)
 - MAKE-UP WATER PRESSURE
20 psi MIN [137 kPa], 50 psi MAX [344 kPa]

- DIMENSIONS LISTED AS FOLLOWS:
ENGLISH IN
[METRIC] [mm]
- * - APPROXIMATE DIMENSIONS DO NOT USE FOR PRE-FABRICATION OF CONNECTING PIPING.

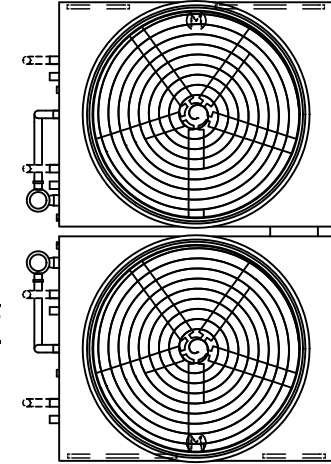

**FACE 2
PLAN VIEW**

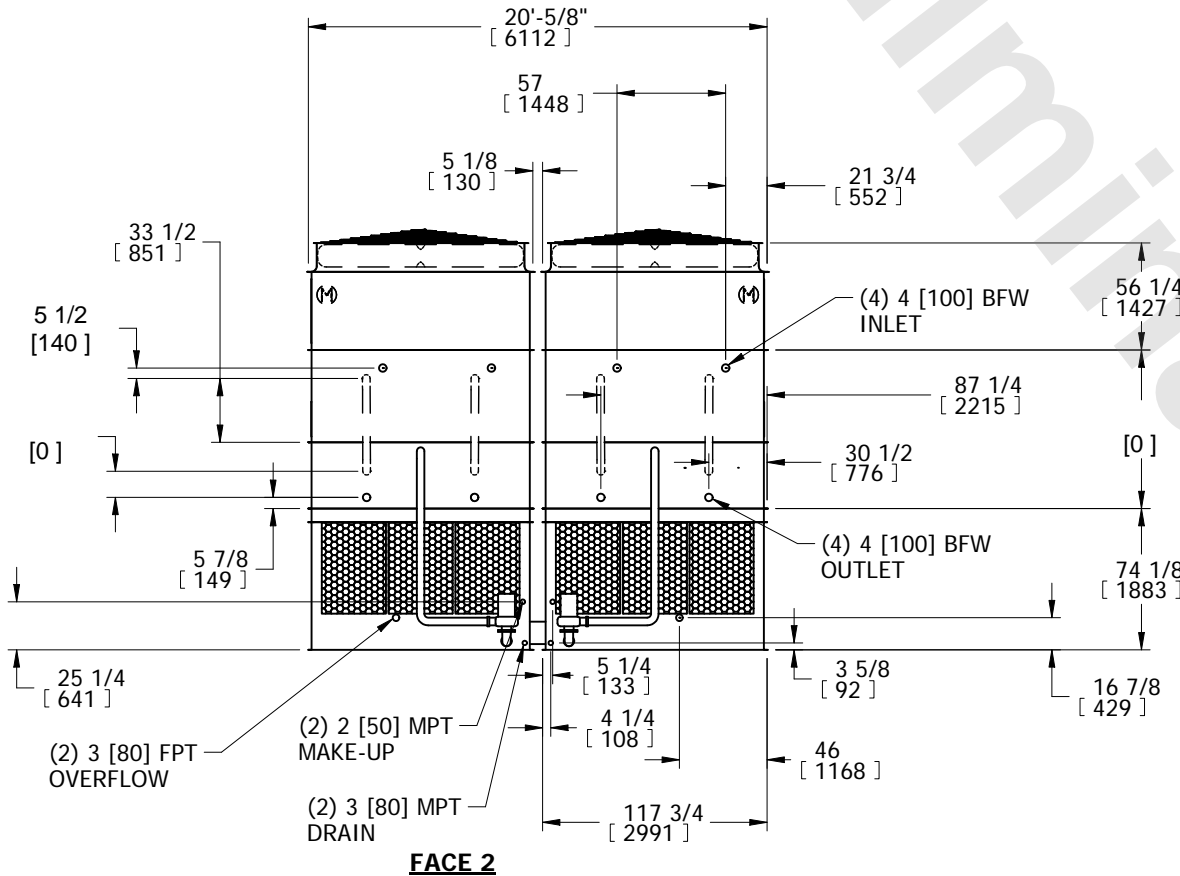

FACE 2

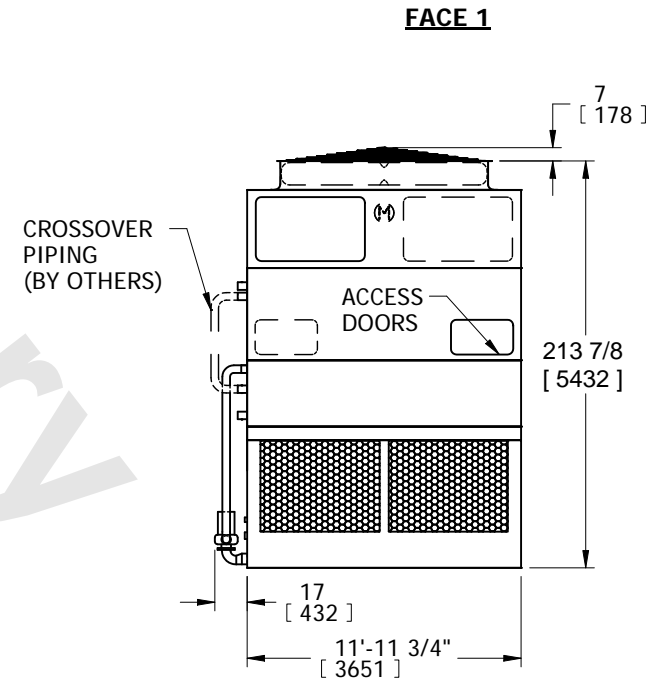

FACE 1

| | | | | |
|-------------------------------------------|--------------------------------------------|--------------------------------------------------|-------------------------------|------------------|
| SHIPPING WEIGHT 35430 lbs+ [16075] kg+ | OPERATING WEIGHT 48000 lbs+ [21775] kg+ | HEAVIEST SECTION WEIGHT 14190 lbs+ [6440] kg+ | NO. OF SHIPPING SECTIONS 6 | DRAWN BY: SFR |
|-------------------------------------------|--------------------------------------------|--------------------------------------------------|-------------------------------|------------------|