

# EVAPCO, INC.



|                               |                                     |                 |                            |           |                  |          |
|-------------------------------|-------------------------------------|-----------------|----------------------------|-----------|------------------|----------|
| UNIT<br>CLOSED CIRCUIT COOLER | MODEL #<br>eco-ATWB-H 12-3N14-Z-U22 | SCALE<br>N.T.S. | DWG. #<br>EGH1214MR-DRC-SF | REV.<br>- | DATE<br>4/7/2026 | SERIAL # |
|-------------------------------|-------------------------------------|-----------------|----------------------------|-----------|------------------|----------|

- NOTES:
- (M)- FAN MOTOR LOCATION
  - HEAVIEST SECTION IS COIL SECTION
  - MPT DENOTES MALE PIPE THREAD  
FPT DENOTES FEMALE PIPE THREAD  
BFW DENOTES BEVELED FOR WELDING  
GVD DENOTES GROOVED  
FLG DENOTES FLANGE
  - +UNIT WEIGHT DOES NOT INCLUDE ACCESSORIES (SEE ACCESSORY DRAWINGS)
  - MAKE-UP WATER PRESSURE  
20 psi MIN [137 kPa], 50 psi MAX [344 kPa]

- 3/4" [19mm] DIA. MOUNTING HOLES. REFER TO RECOMMENDED STEEL SUPPORT DRAWING.
- \* - APPROXIMATE DIMENSIONS DO NOT USE FOR PRE-FABRICATION OF CONNECTING PIPING.

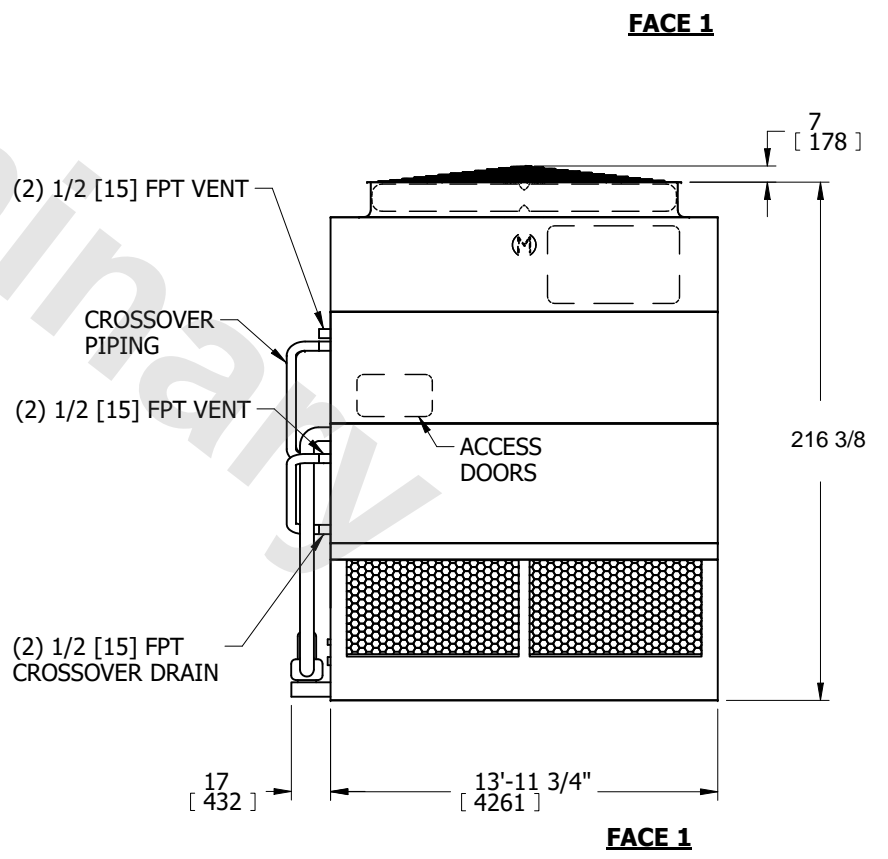
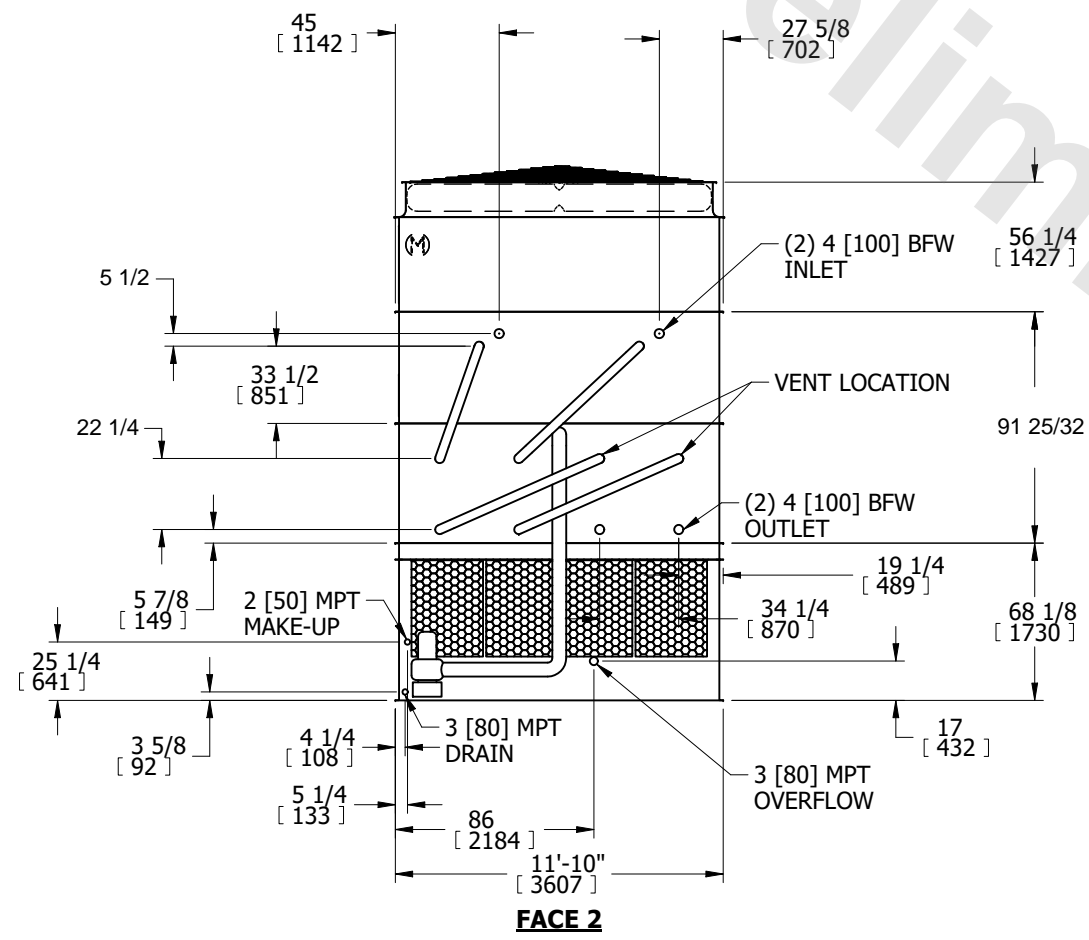
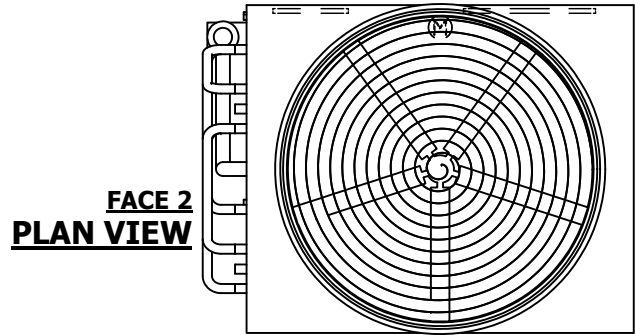

|                                           |                                            |                                                  |                               |                  |
|-------------------------------------------|--------------------------------------------|--------------------------------------------------|-------------------------------|------------------|
| SHIPPING WEIGHT<br>24200 lbs+ [10980] kg+ | OPERATING WEIGHT<br>34260 lbs+ [15545] kg+ | HEAVIEST SECTION WEIGHT<br>17780 lbs+ [8065] kg+ | NO. OF SHIPPING SECTIONS<br>3 | DRAWN BY:<br>SFR |
|-------------------------------------------|--------------------------------------------|--------------------------------------------------|-------------------------------|------------------|