

# EVAPCO, INC.



UNIT	CLOSED CIRCUIT COOLER	MODEL #	eco-ATWB-H 9-1L12-U12	SCALE	N.T.S	DWG. #	EGH091202-DRC-ST	REV.	-	DATE	6/18/2026	SERIAL #	
------	-----------------------	---------	-----------------------	-------	-------	--------	------------------	------	---	------	-----------	----------	--

- NOTES:
- (M)- FAN MOTOR LOCATION
  - HEAVIEST SECTION IS COIL SECTION
  - MPT DENOTES MALE PIPE THREAD  
FPT DENOTES FEMALE PIPE THREAD  
BFW DENOTES BEVELED FOR WELDING
  - +UNIT WEIGHT DOES NOT INCLUDE ACCESSORIES (SEE ACCESSORY DRAWINGS)
  - MAKE-UP WATER PRESSURE  
20 psi MIN [137 kPa], 50 psi MAX [344 kPa]

- DIMENSIONS LISTED AS FOLLOWS:  
ENGLISH IN  
[METRIC] [mm]
- \* - APPROXIMATE DIMENSIONS DO NOT USE FOR PRE-FABRICATION OF CONNECTING PIPING.

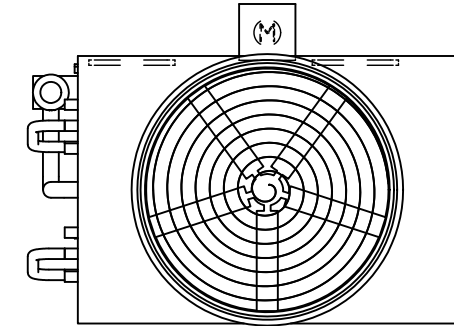

**FACE 2  
PLAN VIEW**

**FACE 1**

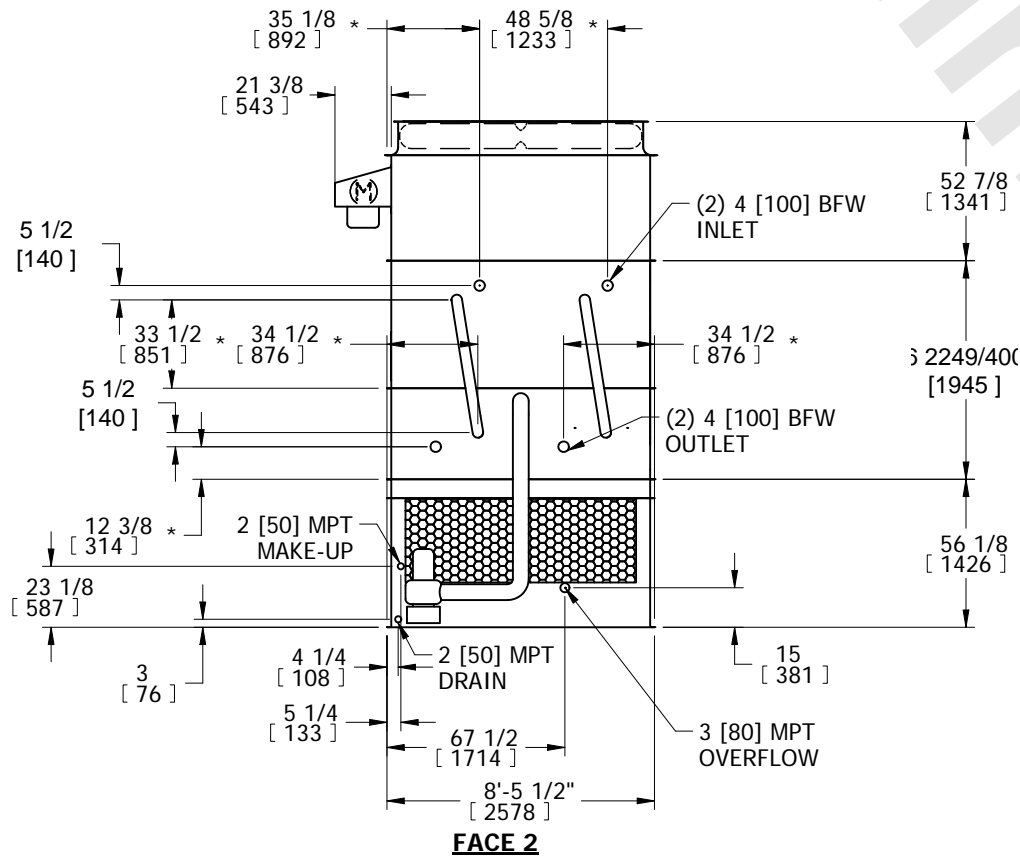

**FACE 2**

(2) 1/2 [15] FPT VENT

CROSSOVER PIPING

ACCESS DOORS

17 [432]

11'-11 3/4" [3651]

185 7/8 [4721]

**FACE 1**

SHIPPING WEIGHT	9970 lbs+ [4525] kg+	OPERATING WEIGHT	14140 lbs+ [6415] kg+	HEAVIEST SECTION WEIGHT	5600 lbs+ [2540] kg+	NO. OF SHIPPING SECTIONS	3	DRAWN BY:	SFR
-----------------	----------------------	------------------	-----------------------	-------------------------	----------------------	--------------------------	---	-----------	-----