

EVAPCO, INC.



| | | | | | | | | | | | | | |
|------|-----------------------|---------|--------------------------|-------|--------|--------|------------------|------|---|------|-----------|----------|--|
| UNIT | CLOSED CIRCUIT COOLER | MODEL # | eco-ATWB-H 10-2K24-Z-U22 | SCALE | N.T.S. | DWG. # | EGHTM24MR-DRB-SF | REV. | - | DATE | 4/27/2026 | SERIAL # | |
|------|-----------------------|---------|--------------------------|-------|--------|--------|------------------|------|---|------|-----------|----------|--|

- NOTES:
- (M)- FAN MOTOR LOCATION
 - HEAVIEST SECTION IS COIL SECTION
 - MPT DENOTES MALE PIPE THREAD
FPT DENOTES FEMALE PIPE THREAD
BFW DENOTES BEVELED FOR WELDING
 - +UNIT WEIGHT DOES NOT INCLUDE ACCESSORIES (SEE ACCESSORY DRAWINGS)
 - MAKE-UP WATER PRESSURE
20 psi MIN [137 kPa], 50 psi MAX [344 kPa]

6. DIMENSIONS LISTED AS FOLLOWS:
ENGLISH IN
[METRIC] [mm]
7. * - APPROXIMATE DIMENSIONS DO NOT USE FOR PRE-FABRICATION OF CONNECTING PIPING.

**FACE 2
PLAN VIEW**



FACE 1

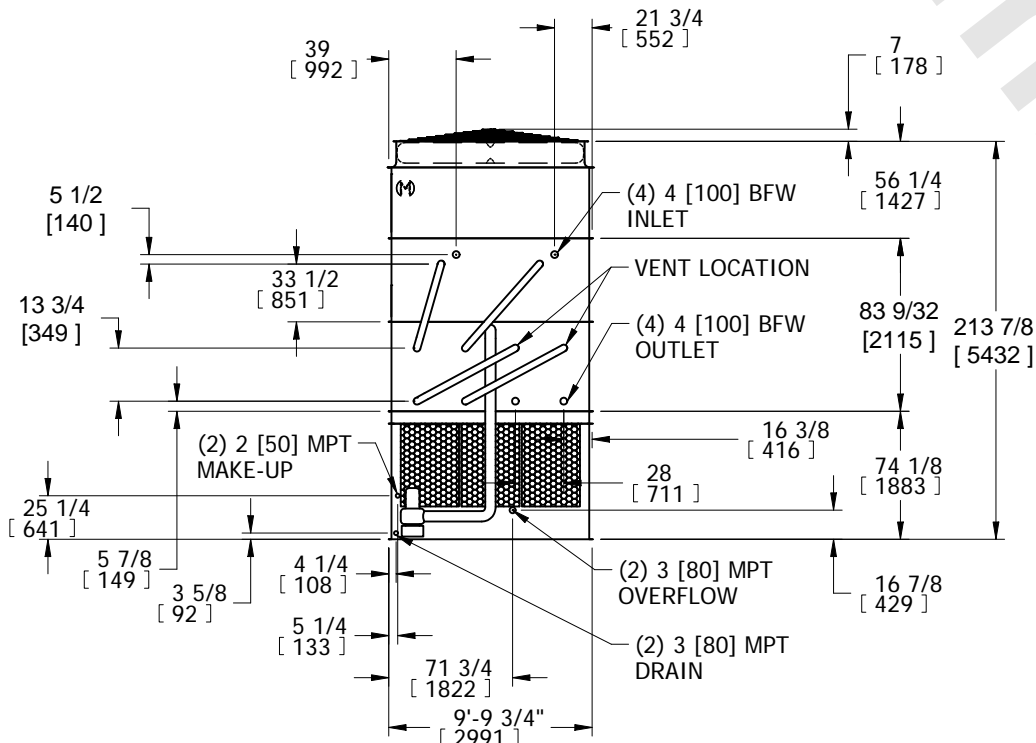

FACE 2



FACE 1

| | | | | | | | | | |
|-----------------|------------------------|------------------|------------------------|-------------------------|-----------------------|--------------------------|---|-----------|-----|
| SHIPPING WEIGHT | 33610 lbs+ [15250] kg+ | OPERATING WEIGHT | 45150 lbs+ [20480] kg+ | HEAVIEST SECTION WEIGHT | 10840 lbs+ [4915] kg+ | NO. OF SHIPPING SECTIONS | 6 | DRAWN BY: | SFR |
|-----------------|------------------------|------------------|------------------------|-------------------------|-----------------------|--------------------------|---|-----------|-----|