

EVAPCO, INC.



| | | | | | | | | | | | | | |
|------|-----------------------|---------|------------------------|-------|--------|--------|------------------|------|---|------|-----------|----------|--|
| UNIT | CLOSED CIRCUIT COOLER | MODEL # | eco-ATWB-H 17-1112-U12 | SCALE | N.T.S. | DWG. # | EGH171202-DRD-ST | REV. | - | DATE | 6/21/2026 | SERIAL # | |
|------|-----------------------|---------|------------------------|-------|--------|--------|------------------|------|---|------|-----------|----------|--|

- NOTES:
- (M)- FAN MOTOR LOCATION
 - HEAVIEST SECTION IS COIL SECTION
 - MPT DENOTES MALE PIPE THREAD
FPT DENOTES FEMALE PIPE THREAD
BFW DENOTES BEVELED FOR WELDING
 - +UNIT WEIGHT DOES NOT INCLUDE ACCESSORIES (SEE ACCESSORY DRAWINGS)
 - MAKE-UP WATER PRESSURE
20 psi MIN [137 kPa], 50 psi MAX [344 kPa]

- DIMENSIONS LISTED AS FOLLOWS:
ENGLISH IN
[METRIC] [mm]
- * - APPROXIMATE DIMENSIONS DO NOT USE FOR PRE-FABRICATION OF CONNECTING PIPING.

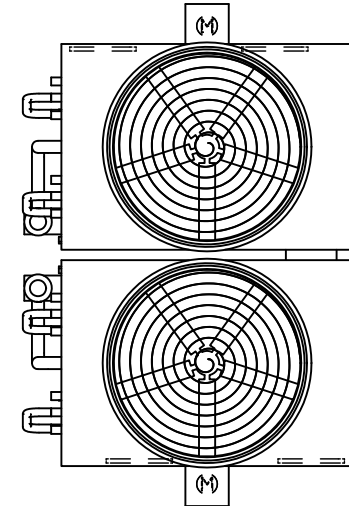

**FACE 2
PLAN VIEW**

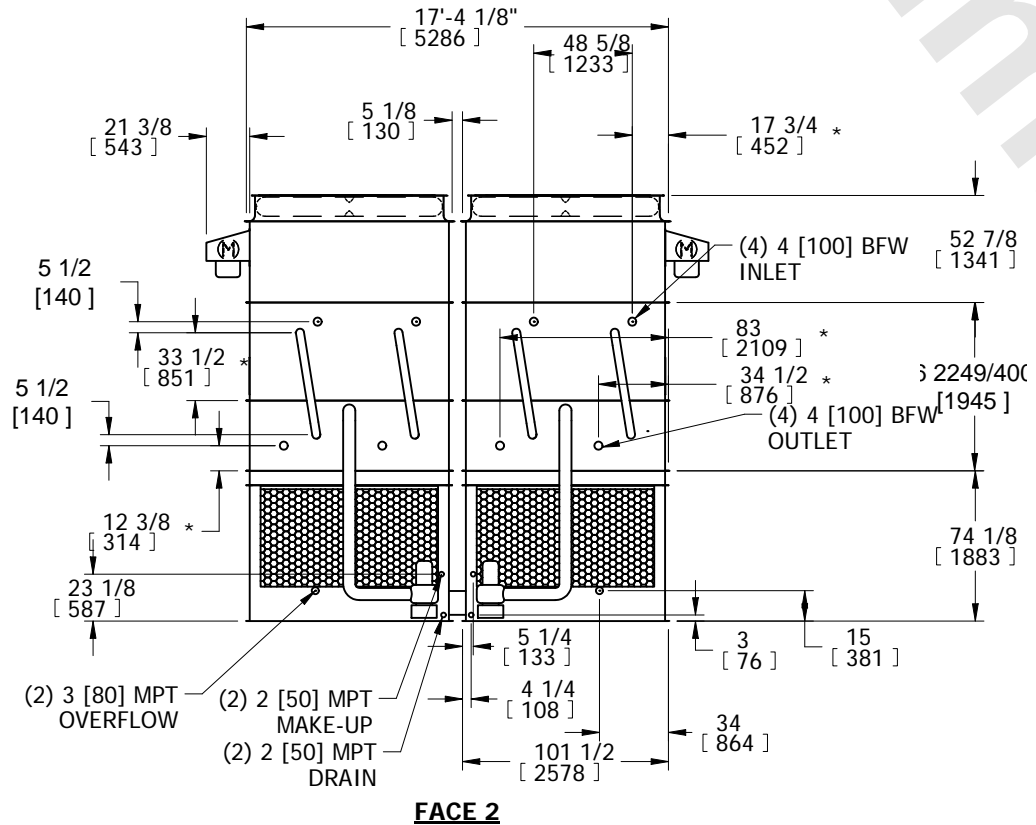

FACE 2

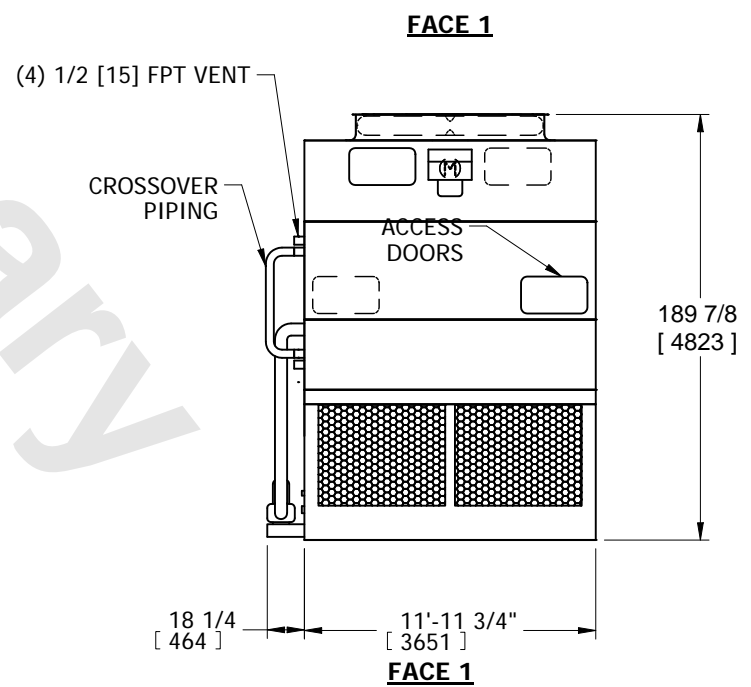

FACE 1

| | | | | | | | | | |
|-----------------|-----------------------|------------------|------------------------|-------------------------|----------------------|--------------------------|---|-----------|-----|
| SHIPPING WEIGHT | 19390 lbs+ [8800] kg+ | OPERATING WEIGHT | 27730 lbs+ [12580] kg+ | HEAVIEST SECTION WEIGHT | 5540 lbs+ [2510] kg+ | NO. OF SHIPPING SECTIONS | 6 | DRAWN BY: | SFR |
|-----------------|-----------------------|------------------|------------------------|-------------------------|----------------------|--------------------------|---|-----------|-----|