

UNIT	COOLING TOWER	
MODEL #	AXS 14-19O24	SCALE



DWG. #	AX142417-DRA-ST	REV.	-
SERIAL #		DATE	6/25/2026

- NOTES:
- (M)- FAN MOTOR LOCATION
 - HEAVIEST SECTION IS UPPER SECTION
 - MPT DENOTES MALE PIPE THREAD
FPT DENOTES FEMALE PIPE THREAD
BFW DENOTES BEVELED FOR WELDING
GVD DENOTES GROOVED
 - +UNIT WEIGHT DOES NOT INCLUDE ACCESSORIES (SEE ACCESSORY DRAWINGS)
 - MAKE-UP WATER PRESSURE
20 psi MIN [137 kPa], 50 psi MAX [344 kPa]
 - 3/4" DIA. MOUNTING HOLES. REFER TO RECOMMENDED STEEL SUPPORT DRAWING.
 - DIMENSIONS LISTED AS FOLLOWS: ENGLISH IN [METRIC] [mm]

**FACE B
PLAN VIEW**



FACE B

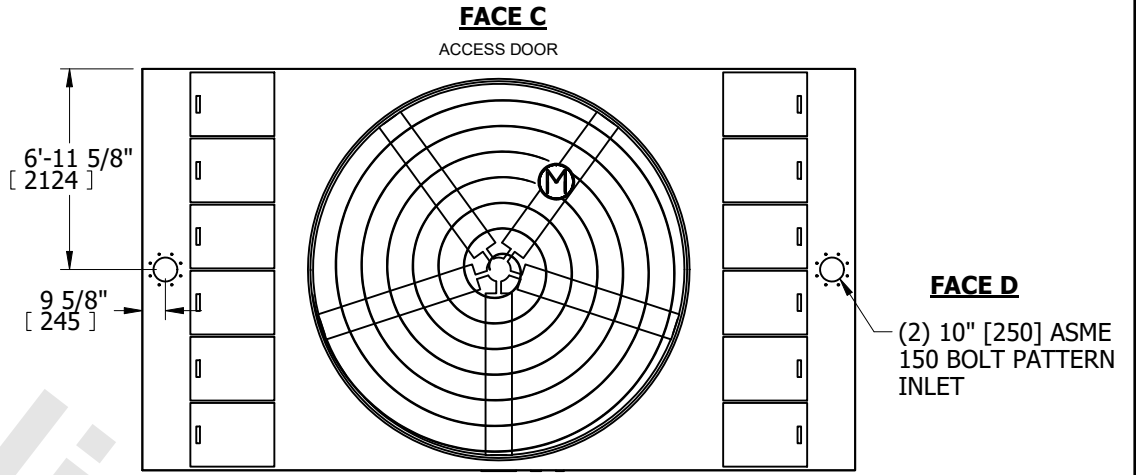

**FACE C
ACCESS DOOR**

FACE D

(2) 10" [250] ASME 150 BOLT PATTERN INLET

FACE A

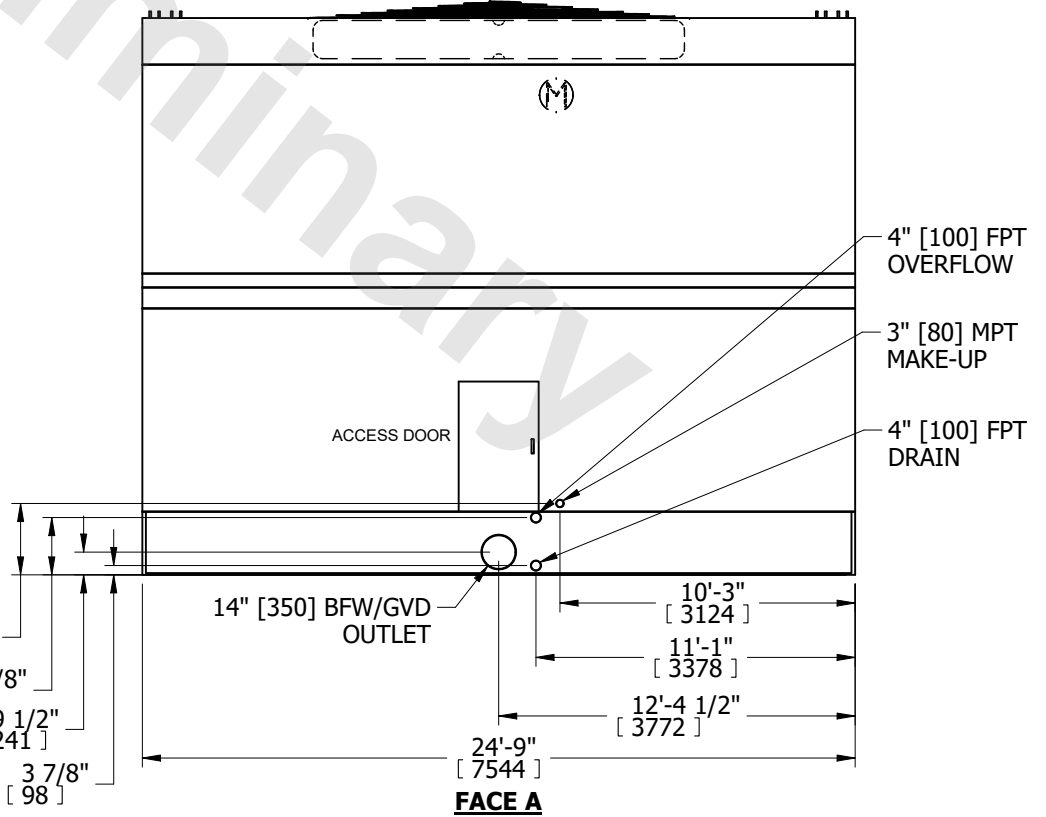

- 4" [100] FPT OVERFLOW
- 3" [80] MPT MAKE-UP
- 4" [100] FPT DRAIN

FACE A

SHIPPING WEIGHT	21480 lbs+ [9745] kg+	OPERATING WEIGHT	48130 lbs+ [21835] kg+	HEAVIEST SECTION WEIGHT	12120 lbs+ [5500] kg+	NO. OF SHIPPING SECTIONS	2	DRAWN BY:	AWT
-----------------	-----------------------	------------------	------------------------	-------------------------	-----------------------	--------------------------	---	-----------	-----