

# EVAPCO, INC.



UNIT <b>EVAPORATIVE CONDENSER</b>	MODEL # eco-PMC-196	SCALE N.T.S.	DWG. # ECE051208-DRA-ST	REV. -	DATE 12/13/2025	SERIAL #
--------------------------------------	------------------------	-----------------	----------------------------	-----------	--------------------	----------

- NOTES:
- (M)- FAN MOTOR LOCATION
  - HEAVIEST SECTION IS UPPER SECTION
  - MPT DENOTES MALE PIPE THREAD  
FPT DENOTES FEMALE PIPE THREAD  
BFW DENOTES BEVELED FOR WELDING
  - +UNIT WEIGHT DOES NOT INCLUDE ACCESSORIES (SEE ACCESSORY DRAWINGS)
  - 3/4" DIA. MOUNTING HOLES. REFER TO RECOMMENDED STEEL SUPPORT DRAWING.
  - MAKE-UP WATER PRESSURE  
20 psi MIN [137 kPa], 50 psi MAX [344 kPa]
  - \* -APPROXIMATE DIMENSIONS DO NOT USE FOR PRE-FABRICATION OF CONNECTING PIPING
  - DIMENSIONS LISTED AS FOLLOWS: ENGLISH IN [METRIC] [mm]

**FACE 1  
PLAN VIEW**

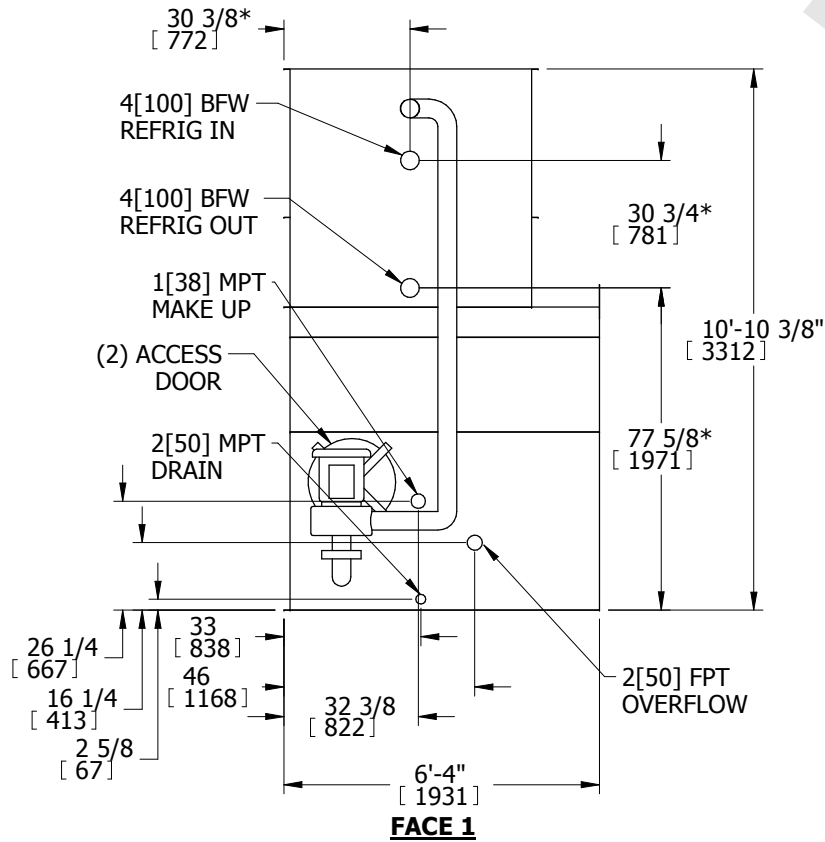
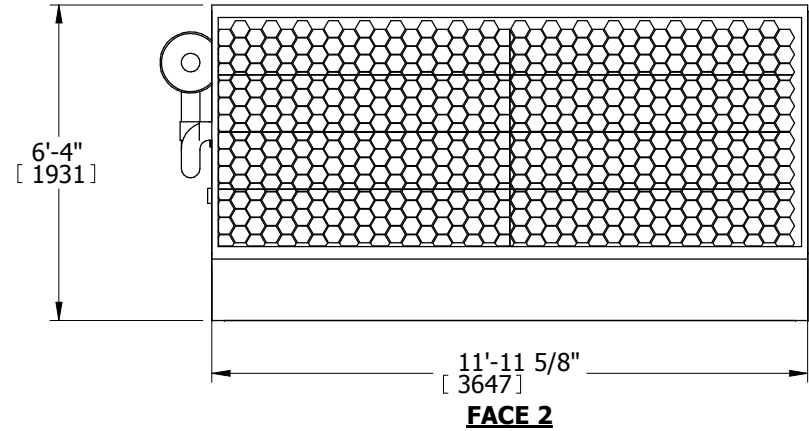

**FACE 1**

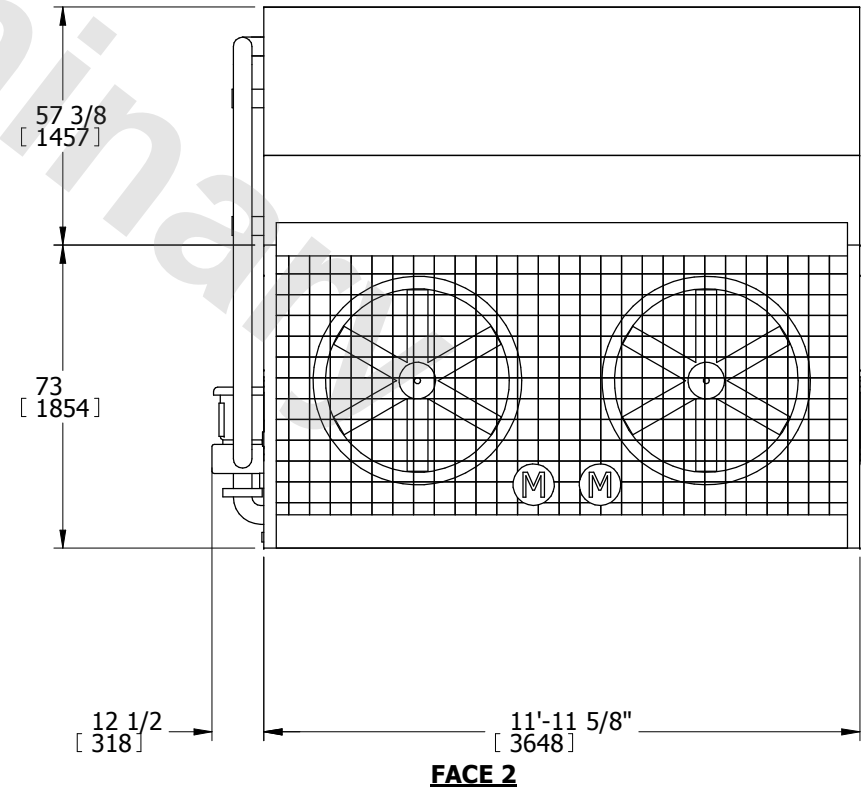

**FACE 2**

SHIPPING WEIGHT 10020 lbs+ [4545] kg+	OPERATING WEIGHT 12340 lbs+ [5597] kg+	HEAVIEST SECTION WEIGHT 6750 lbs+ [3062] kg+	NO. OF SHIPPING SECTIONS 2
--	---	---	-------------------------------