

EVAPCO, INC.



| | | | | | | |
|--------------------------------------|----------------------|-------|----------------------------|-----------|-------------------|----------|
| UNIT EVAPORATIVE CONDENSER | MODEL # PHC-S1042 | SCALE | DWG. # HCS123614-DRC-ST | REV. - | DATE 5/18/2026 | SERIAL # |
|--------------------------------------|----------------------|-------|----------------------------|-----------|-------------------|----------|

- NOTES:
- (M)- FAN MOTOR LOCATION
 - HEAVIEST SECTION IS UPPER SECTION
 - MPT DENOTES MALE PIPE THREAD
FPT DENOTES FEMALE PIPE THREAD
BFW DENOTES BEVELED FOR WELDING
GVD DENOTES GROOVED
 - +UNIT WEIGHT DOES NOT INCLUDE ACCESSORIES (SEE ACCESSORY DRAWINGS)
 - MAKE-UP WATER PRESSURE
20 psi MIN [137 kPa], 50 psi MAX [344 kPa]
 - 3/4" DIA. MOUNTING HOLES. REFER TO RECOMMENDED STEEL SUPPORT DRAWING.
 - *- APPROXIMATE DIMENSIONS DO NOT USE FOR PRE-FABRICATION OF CONNECTION PIPING.
 - **-UNITS WITH 20HP PER FAN REQUIRE A TALLER FAN CYLINDER, ADD 5" TO THESE DIMENSIONS.
 - DIMENSIONS LISTED AS FOLLOWS: ENGLISH IN [METRIC] [mm]

FACE 2
PLAN VIEW

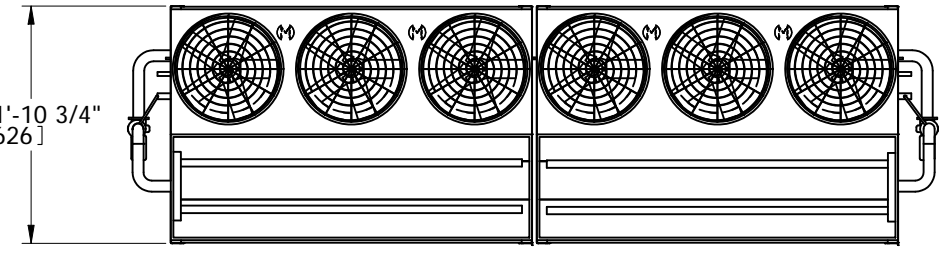

FACE 1

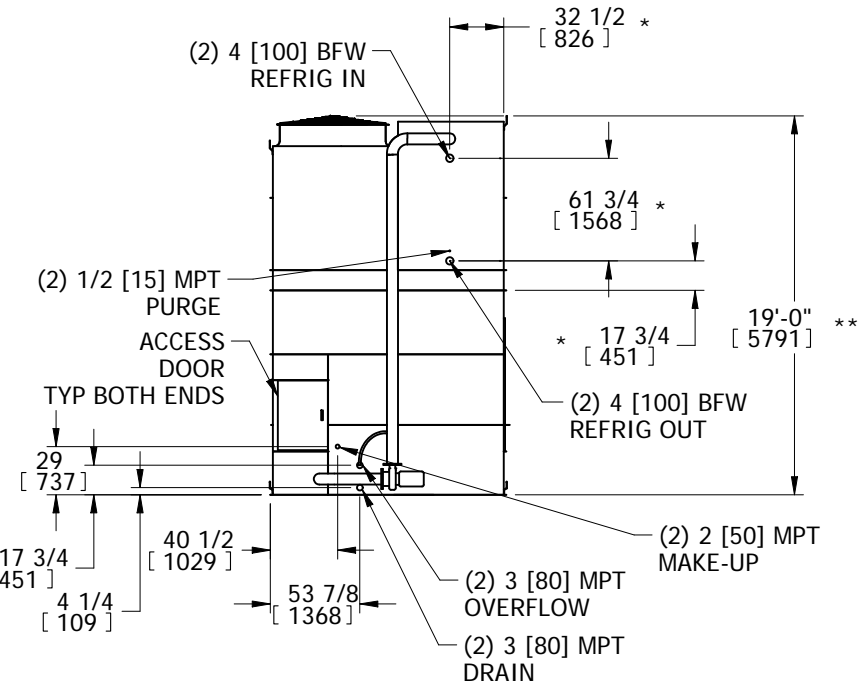

FACE 2

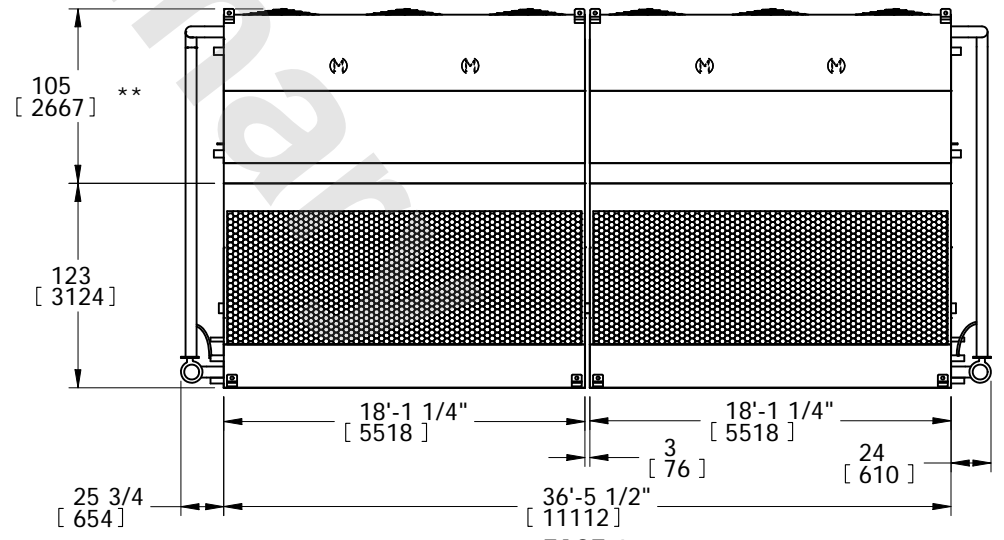

FACE 1

| | | | | |
|---|--|--|-------------------------------|------------------|
| SHIPPING WEIGHT 48320 lbs+ [21920] kg+ | OPERATING WEIGHT 64780 lbs+ [29385] kg+ | HEAVIEST SECTION WEIGHT 17170 lbs+ [7790] kg+ | NO. OF SHIPPING SECTIONS 4 | DRAWN BY: TLS |
|---|--|--|-------------------------------|------------------|