

EVAPCO, INC.



UNIT CONDENSER	MODEL # eco-ATC-1250A	SCALE N.T.S.	DWG. # EG241806-DRA-ST	REV. -	DATE 10/11/2025	SERIAL #
--------------------------	--------------------------	-----------------	---------------------------	-----------	--------------------	----------

- NOTES:
- (M)- FAN MOTOR LOCATION
 - HEAVIEST SECTION IS UPPER SECTION
 - MPT DENOTES MALE PIPE THREAD
FPT DENOTES FEMALE PIPE THREAD
BFW DENOTES BEVELED FOR WELDING
 - +UNIT WEIGHT DOES NOT INCLUDE ACCESSORIES (SEE ACCESSORY DRAWINGS)
 - MAKE-UP WATER PRESSURE
20 psi MIN [137 kPa], 50 psi MAX [344 kPa]
 - * -APPROXIMATE DIMENSIONS DO NOT USE FOR PRE-FABRICATION OF CONNECTING PIPING
 - VENT PROVIDED ON CLOSED CIRCUIT COOLERS ONLY

Preliminary

**FACE 2
PLAN VIEW**

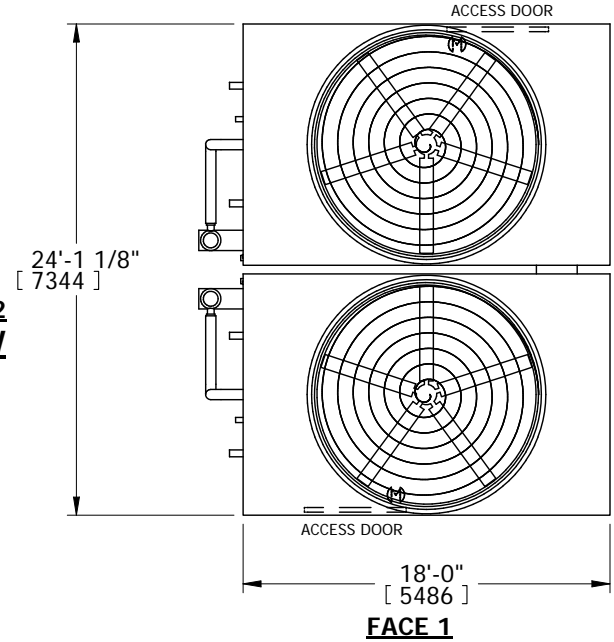

FACE 1

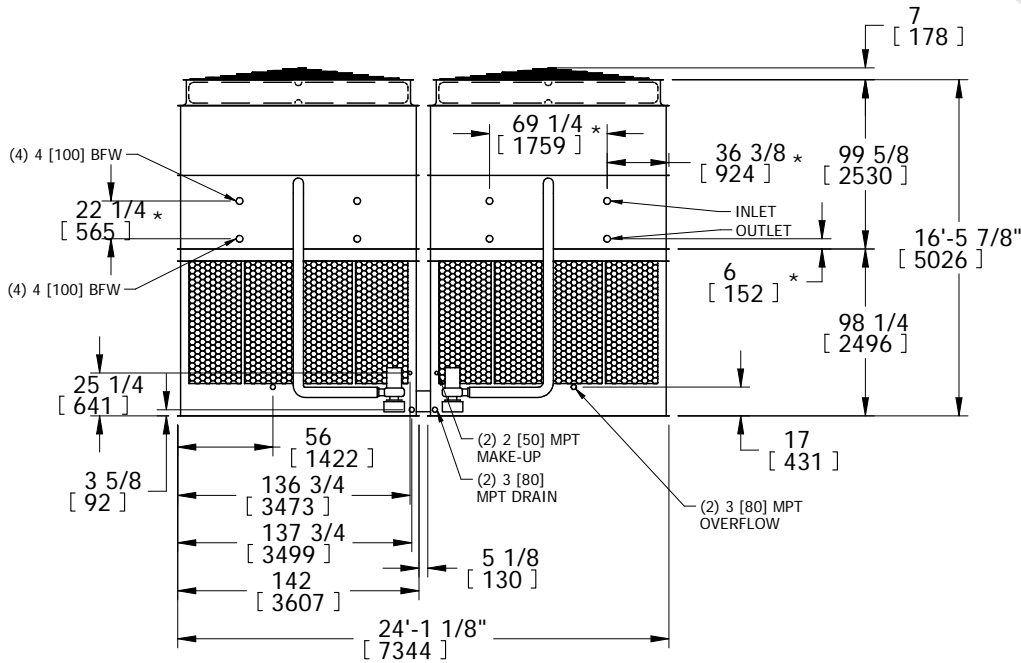

FACE 2

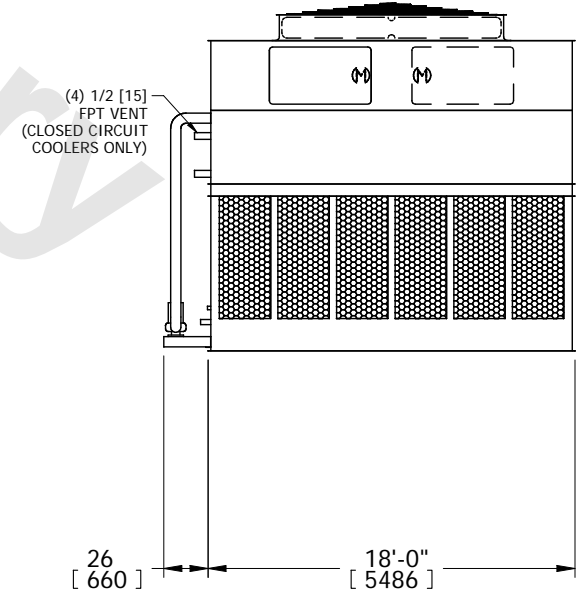

FACE 1

SHIPPING WEIGHT 48600 lbs+ [22045] kg+	OPERATING WEIGHT 68520 lbs+ [31085] kg+	HEAVIEST SECTION WEIGHT 20380 lbs+ [9245] kg+	NO. OF SHIPPING SECTIONS 4
--	---	---	--------------------------------------