

|         |                       |
|---------|-----------------------|
| UNIT    | CLOSED CIRCUIT COOLER |
| MODEL # | ESW4 12-46J18-SF      |
| SCALE   | NTS                   |

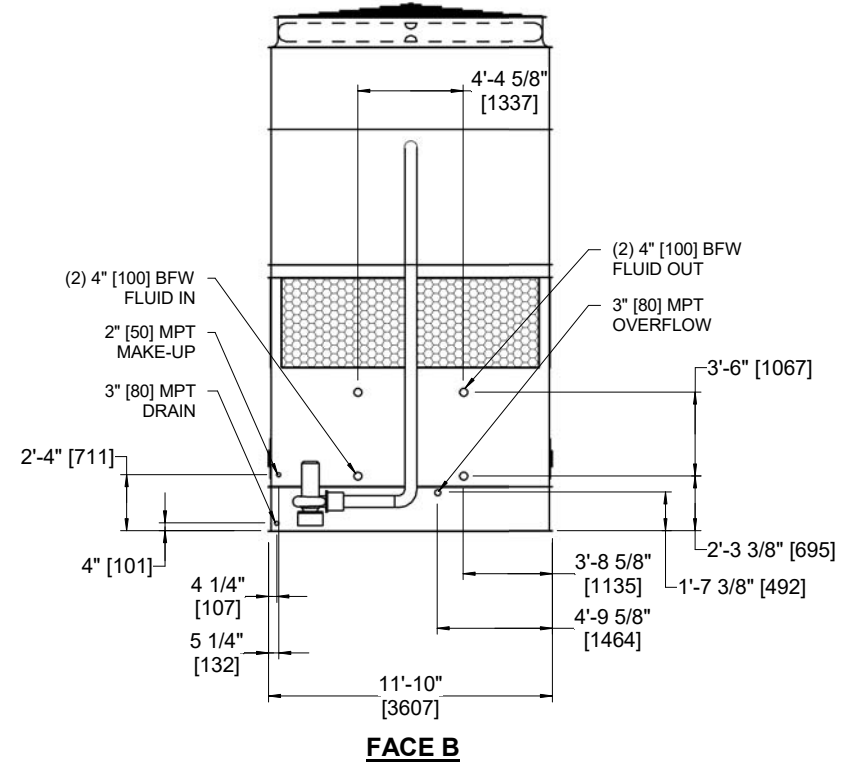

|          |                     |       |           |
|----------|---------------------|-------|-----------|
| DWG. #   | WX412184812F-DRA-ST | REV   | -         |
| SERIAL # |                     | DATE: | 5/18/2026 |

- NOTES:
- (M)- FAN MOTOR LOCATION
  - HEAVIEST SECTION IS COIL SECTION
  - MPT DENOTES MALE PIPE THREAD  
FPT DENOTES FEMALE PIPE THREAD  
BFW DENOTES BEVELED FOR WELDING  
GVD DENOTES GROOVED  
FLG DENOTES FLANGE
  - +UNIT WEIGHT DOES NOT INCLUDE ACCESSORIES (SEE ACCESSORY DRAWINGS)
  - 3/4" [19MM] DIA. MOUNTING HOLES. REFER TO RECOMMENDED STEEL SUPPORT DRAWING
  - MAKE-UP WATER PRESSURE  
20 psi MIN [137 kPa], 50 psi MAX [344 kPa]
  - DIMENSIONS LISTED AS FOLLOWS:  
ENGLISH FT-IN  
[METRIC] [mm]
  - \* - APPROXIMATE DIMENSIONS DO NOT USE FOR PRE-FABRICATION OF CONNECTING PIPING

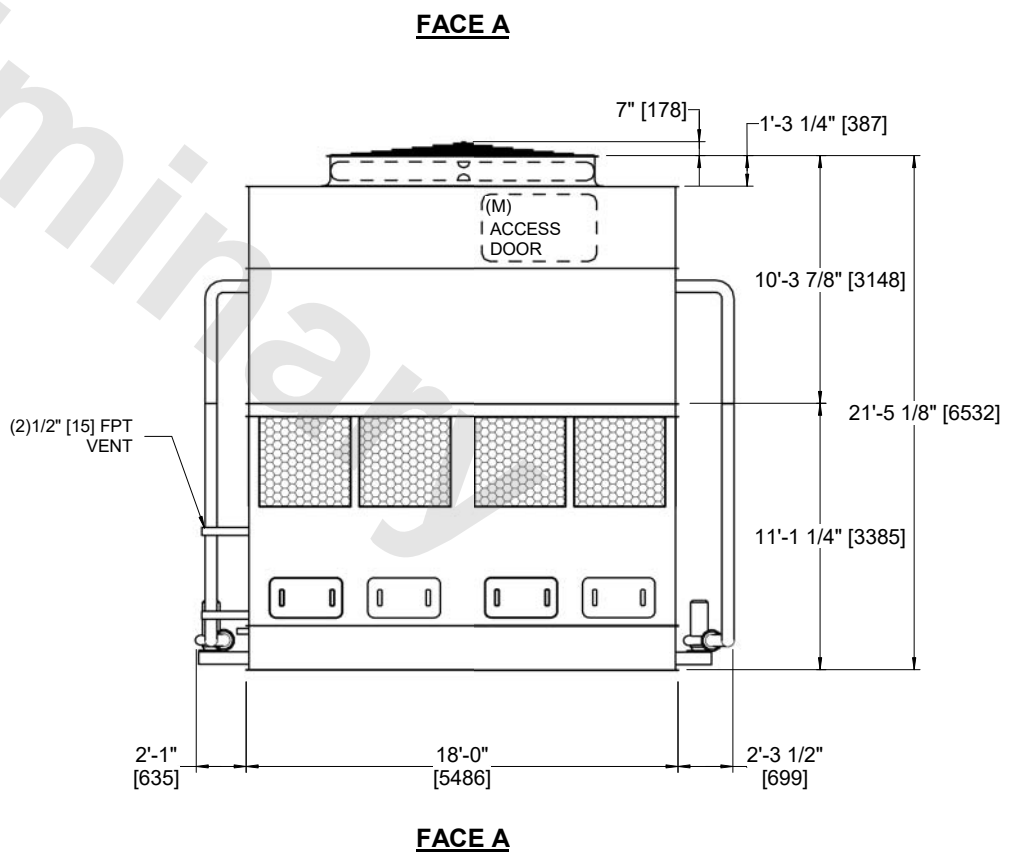
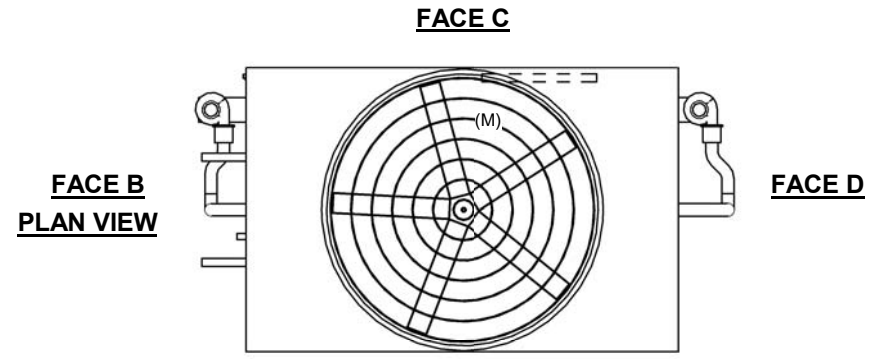

|                 |                        |                  |                        |                         |                        |                          |   |           |     |
|-----------------|------------------------|------------------|------------------------|-------------------------|------------------------|--------------------------|---|-----------|-----|
| SHIPPING WEIGHT | 36200 lbs+ [16425] kg+ | OPERATING WEIGHT | 52770 lbs+ [23940] kg+ | HEAVIEST SECTION WEIGHT | 28110 lbs+ [12755] kg+ | NO. OF SHIPPING SECTIONS | 2 | DRAWN BY: | AWT |
|-----------------|------------------------|------------------|------------------------|-------------------------|------------------------|--------------------------|---|-----------|-----|