

CONFIDENTIAL

This document is the property of Evapco, Inc. It should not be copied or disclosed without prior written authorization.

CUSTOMER	MODEL # U-SSTWE2-19R66F0100F1KA	SCALE N.T.S.	DWG. # USSTW2-SE-6L	REV. 0	DATE 10/21/2025
----------	---------------------------------	--------------	---------------------	--------	-----------------

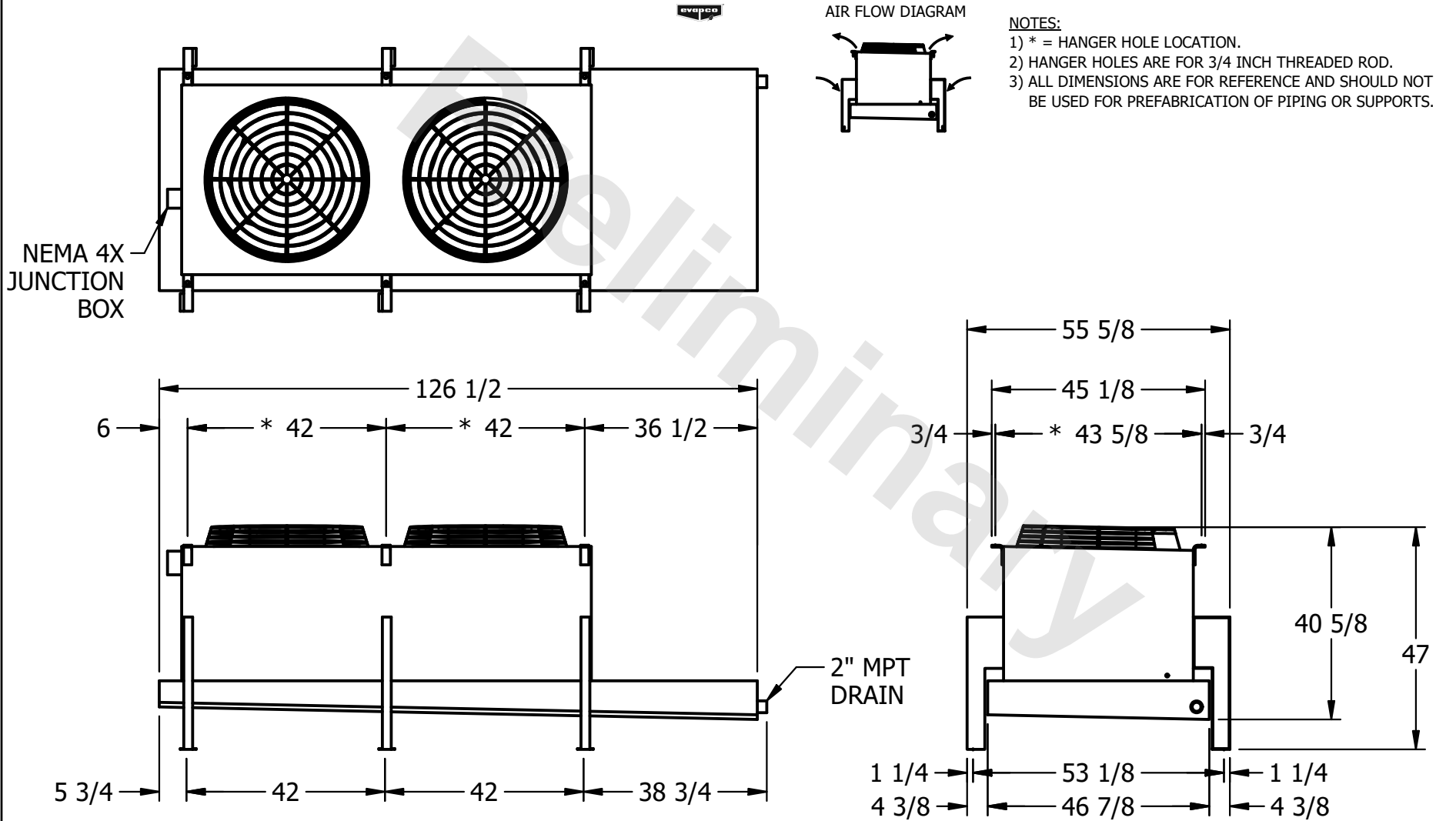

PROJECT	ROOM	SHIPPING WEIGHT 1070 lbs+ [490] kg+	OPERATING WEIGHT 1250 lbs+ [570] kg+
---------	------	-------------------------------------	--------------------------------------