

CONFIDENTIAL

This document is the property of Evapco, Inc. It should not be copied or disclosed without prior written authorization.

CUSTOMER	MODEL # U-SSTWE2-19R63H0100F1LA	SCALE N.T.S.	DWG. # USSTW2-SE-6L	REV. 0	DATE 12/16/2025
----------	---------------------------------	--------------	---------------------	--------	-----------------

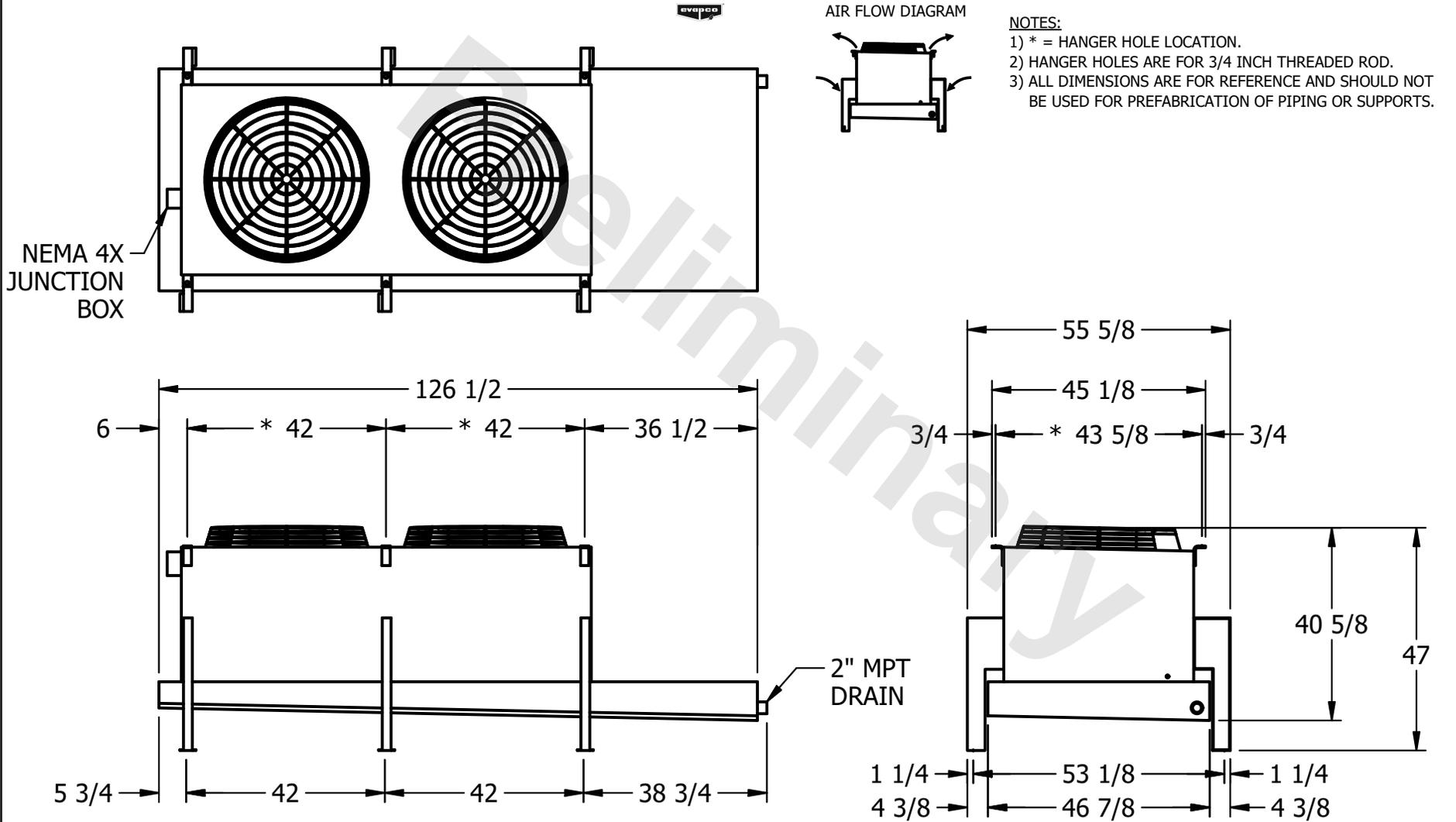

PROJECT	ROOM	SHIPPING WEIGHT 1080 lbs+ [490] kg+	OPERATING WEIGHT 1190 lbs+ [540] kg+
---------	------	-------------------------------------	--------------------------------------