

EVAPCO, INC.



| | | | | | | | | | | | | | |
|------|-----------------------|---------|-----------------------|-------|-------|--------|------------------|------|---|------|----------|----------|--|
| UNIT | CLOSED CIRCUIT COOLER | MODEL # | eco-ATWB-H 9-3K12-U12 | SCALE | N.T.S | DWG. # | EGH0912MR-DRC-ST | REV. | - | DATE | 4/5/2026 | SERIAL # | |
|------|-----------------------|---------|-----------------------|-------|-------|--------|------------------|------|---|------|----------|----------|--|

- NOTES:
- (M)- FAN MOTOR LOCATION
 - HEAVIEST SECTION IS COIL SECTION
 - MPT DENOTES MALE PIPE THREAD
FPT DENOTES FEMALE PIPE THREAD
BFW DENOTES BEVELED FOR WELDING
 - +UNIT WEIGHT DOES NOT INCLUDE ACCESSORIES (SEE ACCESSORY DRAWINGS)
 - MAKE-UP WATER PRESSURE
20 psi MIN [137 kPa], 50 psi MAX [344 kPa]

- DIMENSIONS LISTED AS FOLLOWS:
ENGLISH IN
[METRIC] [mm]
- * - APPROXIMATE DIMENSIONS DO NOT USE FOR PRE-FABRICATION OF CONNECTING PIPING.

**FACE 2
PLAN VIEW**



FACE 1

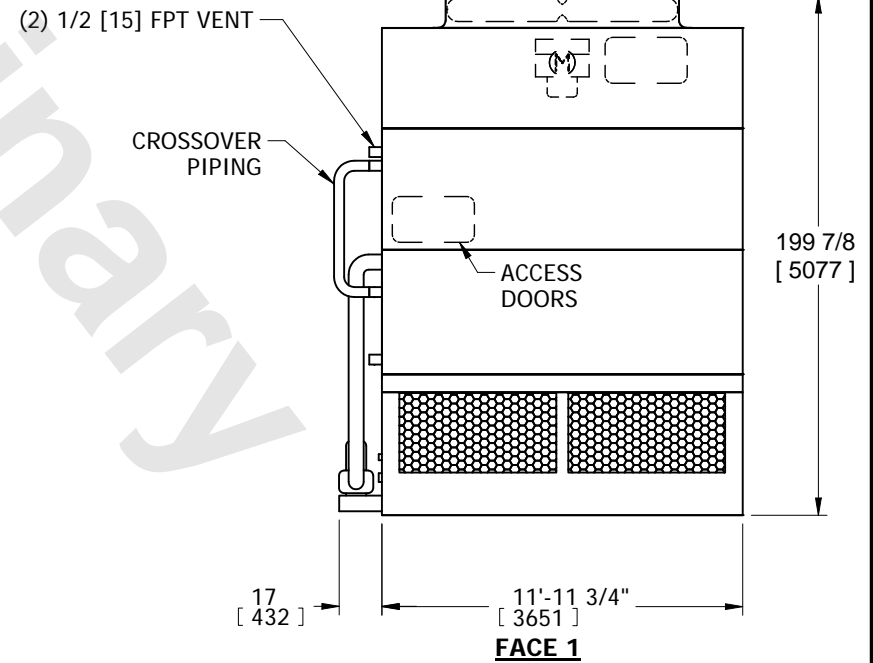
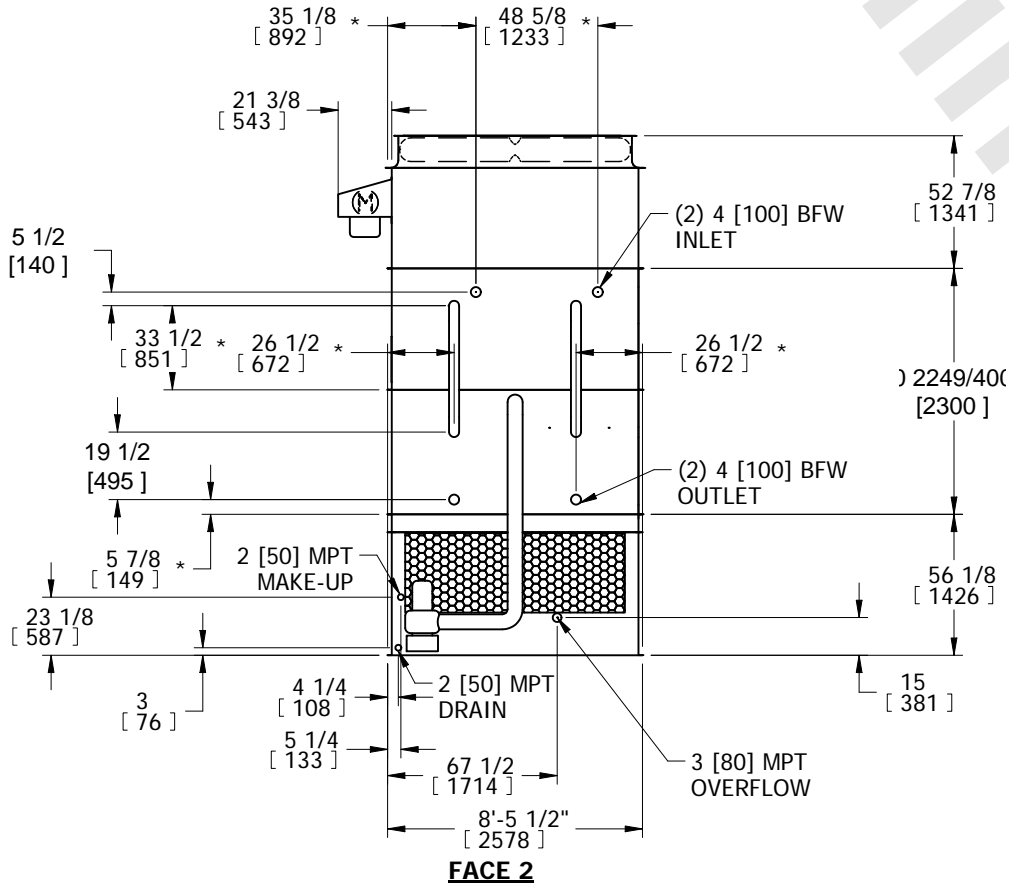

FACE 2

FACE 1

| | | | | | | | | | |
|-----------------|-----------------------|------------------|-----------------------|-------------------------|-----------------------|--------------------------|---|-----------|-----|
| SHIPPING WEIGHT | 14470 lbs+ [6565] kg+ | OPERATING WEIGHT | 19760 lbs+ [8965] kg+ | HEAVIEST SECTION WEIGHT | 10130 lbs+ [4595] kg+ | NO. OF SHIPPING SECTIONS | 3 | DRAWN BY: | SFR |
|-----------------|-----------------------|------------------|-----------------------|-------------------------|-----------------------|--------------------------|---|-----------|-----|