

EVAPCO, INC.



| | | | | | | |
|-------------------------------|-----------------------------------|-----------------|----------------------------|-----------|------------------|----------|
| UNIT CLOSED CIRCUIT COOLER | MODEL # eco-ATWB-H 9-2J9-Z-U22 | SCALE N.T.S. | DWG. # EGH0909MR-DRB-SF | REV. - | DATE 4/6/2026 | SERIAL # |
|-------------------------------|-----------------------------------|-----------------|----------------------------|-----------|------------------|----------|

- NOTES:
- (M)- FAN MOTOR LOCATION
 - HEAVIEST SECTION IS COIL SECTION
 - MPT DENOTES MALE PIPE THREAD
FPT DENOTES FEMALE PIPE THREAD
BFW DENOTES BEVELED FOR WELDING
 - +UNIT WEIGHT DOES NOT INCLUDE ACCESSORIES (SEE ACCESSORY DRAWINGS)
 - MAKE-UP WATER PRESSURE
20 psi MIN [137 kPa], 50 psi MAX [344 kPa]

6. DIMENSIONS LISTED AS FOLLOWS:
ENGLISH IN
[METRIC] [mm]
7. * - APPROXIMATE DIMENSIONS DO NOT USE FOR PRE-FABRICATION OF CONNECTING PIPING.

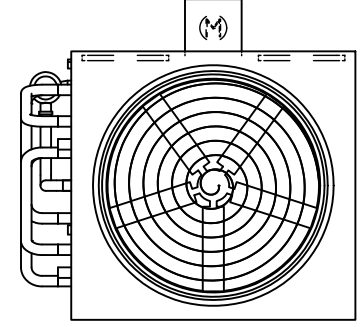

**FACE 2
PLAN VIEW**

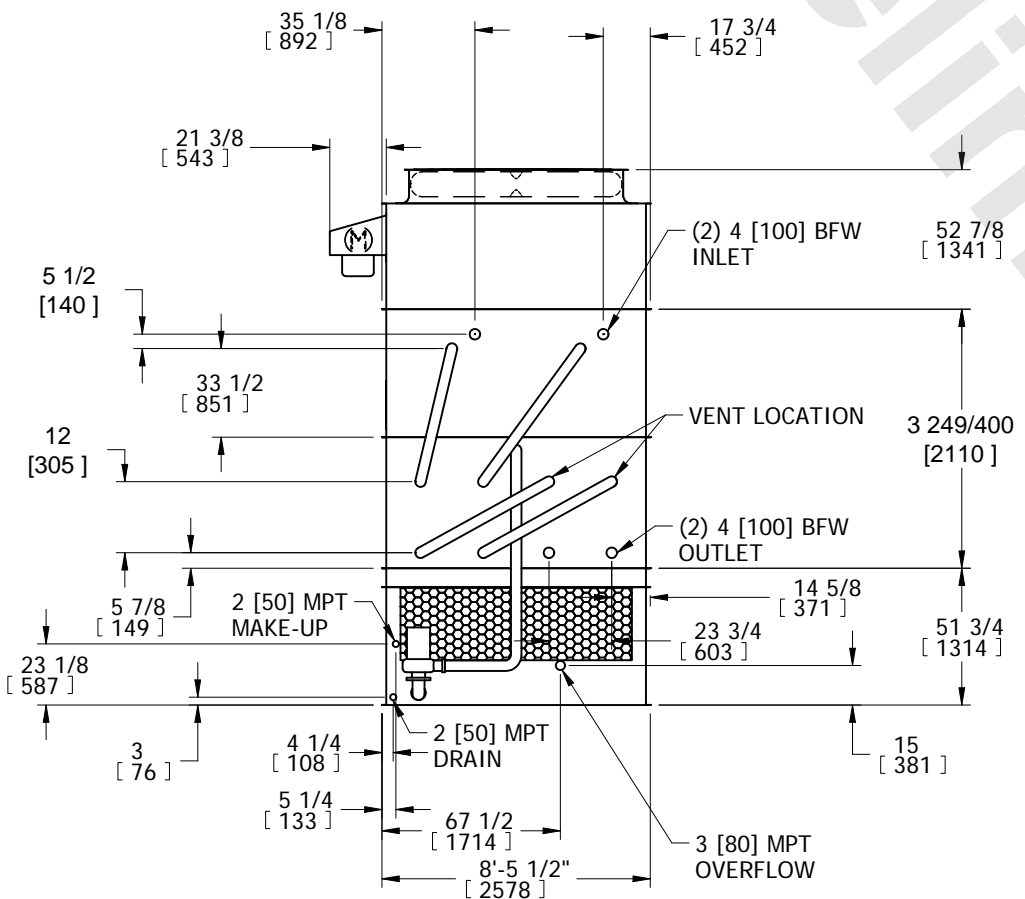

FACE 2

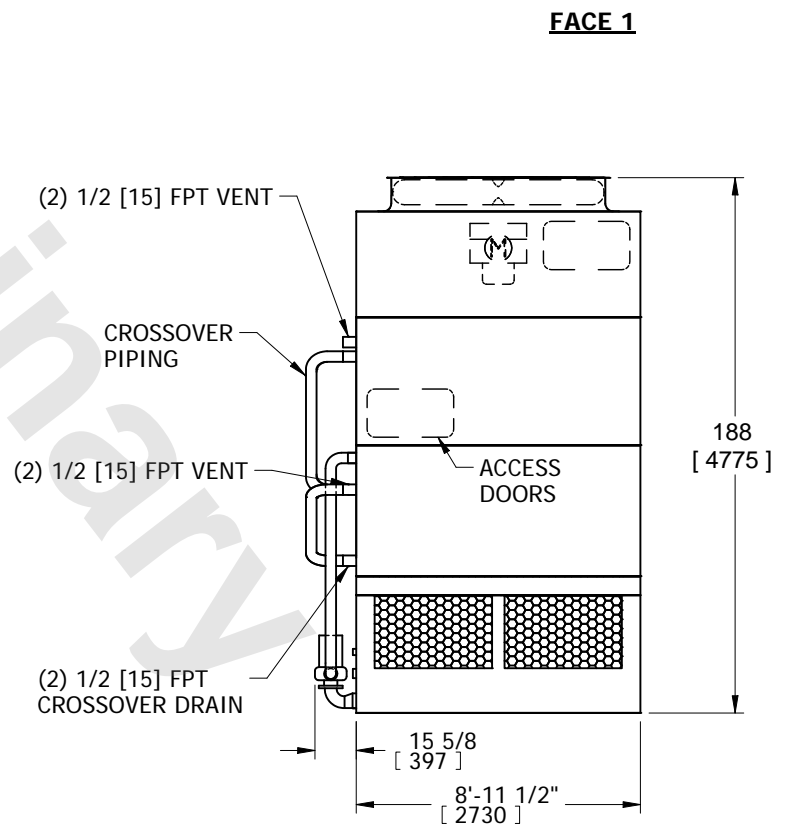

FACE 1

| | | | | |
|--|---|---|-------------------------------|------------------|
| SHIPPING WEIGHT 10500 lbs+ [4765] kg+ | OPERATING WEIGHT 14050 lbs+ [6375] kg+ | HEAVIEST SECTION WEIGHT 6950 lbs+ [3155] kg+ | NO. OF SHIPPING SECTIONS 3 | DRAWN BY: SFR |
|--|---|---|-------------------------------|------------------|