

EVAPCO, INC.



| | | | | | | |
|-------------------------------|-------------------------------------|-----------------|----------------------------|-----------|------------------|----------|
| UNIT CLOSED CIRCUIT COOLER | MODEL # eco-ATWB-H 12-4L20-Z-U22 | SCALE N.T.S. | DWG. # EGH1220MR-DRB-SF | REV. - | DATE 4/7/2026 | SERIAL # |
|-------------------------------|-------------------------------------|-----------------|----------------------------|-----------|------------------|----------|

- NOTES:
1. (M)- FAN MOTOR LOCATION
 2. HEAVIEST SECTION IS COIL SECTION
 3. MPT DENOTES MALE PIPE THREAD
FPT DENOTES FEMALE PIPE THREAD
BFW DENOTES BEVELED FOR WELDING
 4. +UNIT WEIGHT DOES NOT INCLUDE
ACCESSORIES (SEE ACCESSORY
DRAWINGS)
 5. MAKE-UP WATER PRESSURE
20 psi MIN [137 kPa], 50 psi MAX [344 kPa]

6. DIMENSIONS LISTED AS FOLLOWS:
ENGLISH IN
[METRIC] [mm]
7. * - APPROXIMATE DIMENSIONS DO
NOT USE FOR PRE-FABRICATION
OF CONNECTING PIPING.

**FACE 2
PLAN VIEW**

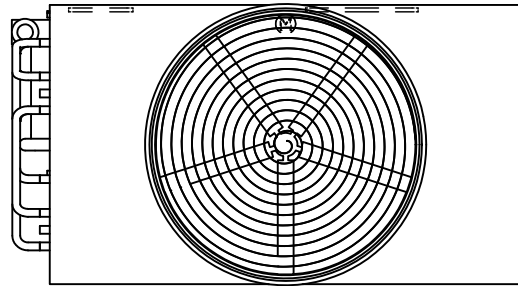

FACE 1

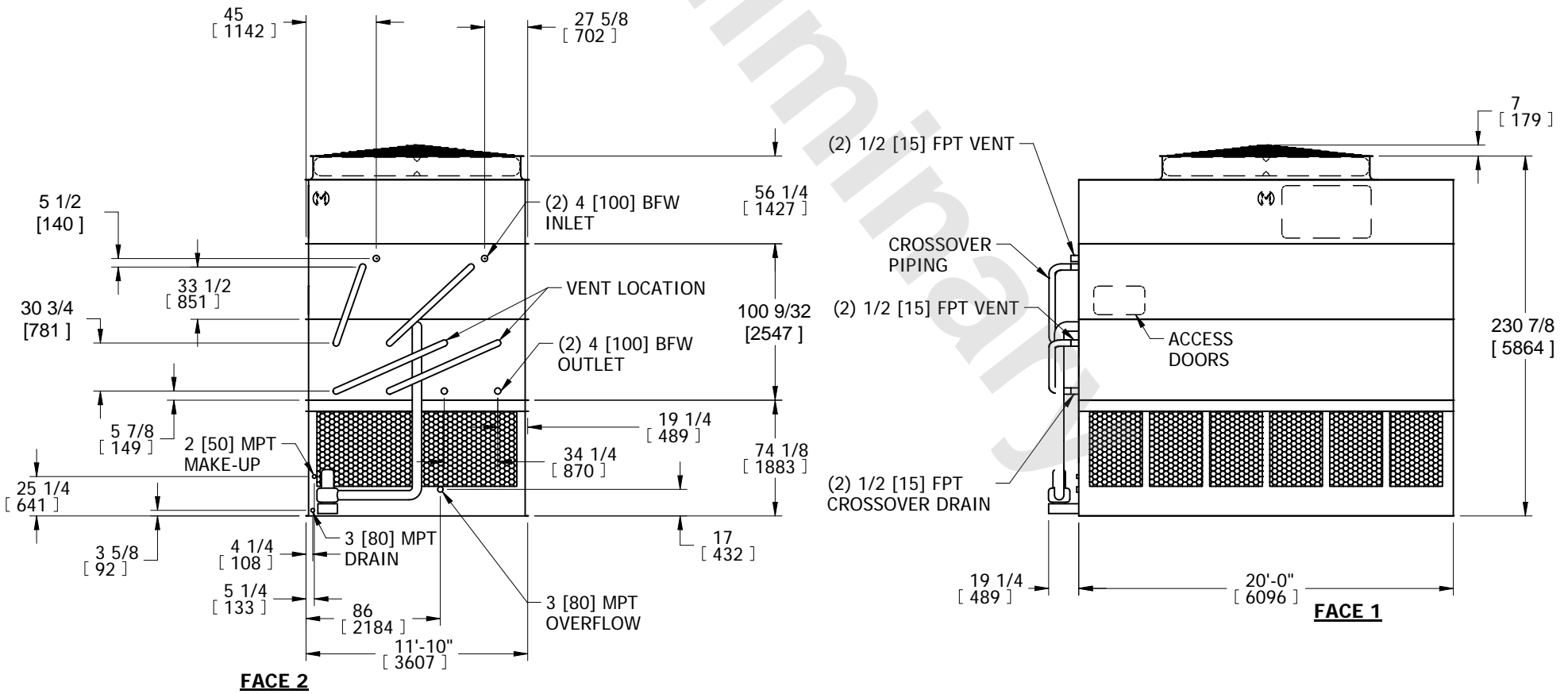

| | | | | |
|---|--|---|-------------------------------|------------------|
| SHIPPING WEIGHT 38390 lbs+ [17415] kg+ | OPERATING WEIGHT 54090 lbs+ [24535] kg+ | HEAVIEST SECTION WEIGHT 30010 lbs+ [13610] kg+ | NO. OF SHIPPING SECTIONS 3 | DRAWN BY: SFR |
|---|--|---|-------------------------------|------------------|