

UNIT	COOLING TOWER	
MODEL #	AXS 14-16Q24	SCALE



DWG. #	AX142413-DRA-ST	REV.	-
SERIAL #		DATE	6/25/2026

- NOTES:
1. (M)- FAN MOTOR LOCATION
 2. HEAVIEST SECTION IS UPPER SECTION
 3. MPT DENOTES MALE PIPE THREAD
FPT DENOTES FEMALE PIPE THREAD
BFW DENOTES BEVELED FOR WELDING
GVD DENOTES GROOVED
 4. +UNIT WEIGHT DOES NOT INCLUDE ACCESSORIES (SEE ACCESSORY DRAWINGS)
 5. MAKE-UP WATER PRESSURE
20 psi MIN [137 kPa], 50 psi MAX [344 kPa]
 6. 3/4" DIA. MOUNTING HOLES. REFER TO RECOMMENDED STEEL SUPPORT DRAWING.
 7. DIMENSIONS LISTED AS FOLLOWS: ENGLISH IN [METRIC] [mm]

**FACE B
PLAN VIEW**



FACE D
(2) 10" [250] ASME 150 BOLT PATTERN INLET

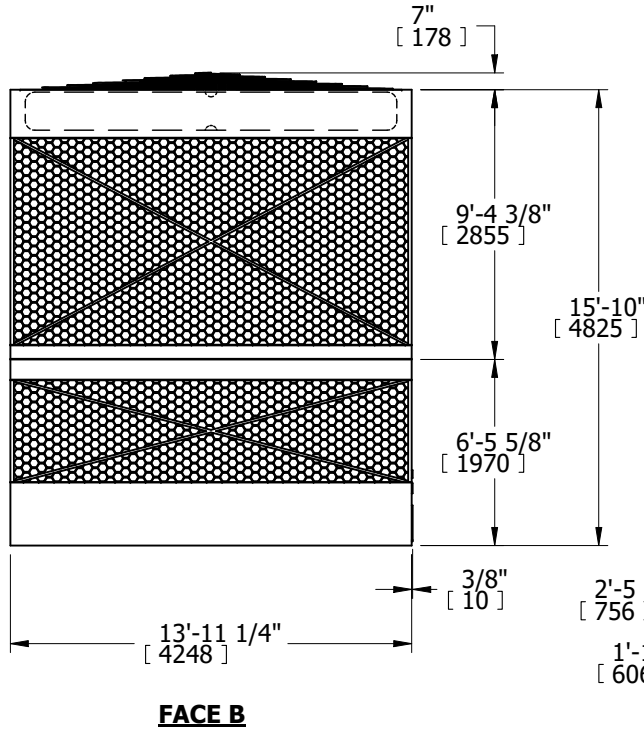

FACE B

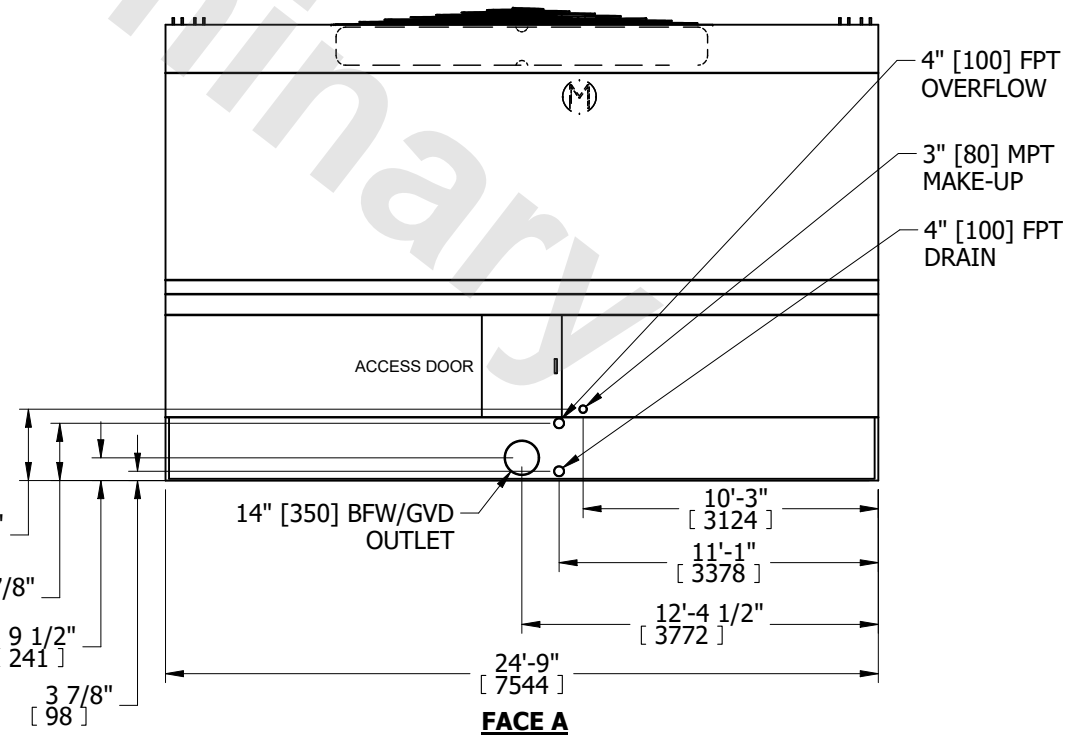

FACE A

4" [100] FPT OVERFLOW
3" [80] MPT MAKE-UP
4" [100] FPT DRAIN

SHIPPING WEIGHT	20220 lbs+ [9175] kg+	OPERATING WEIGHT	46870 lbs+ [21260] kg+	HEAVIEST SECTION WEIGHT	12120 lbs+ [5500] kg+	NO. OF SHIPPING SECTIONS	2	DRAWN BY:	AWT
-----------------	-----------------------	------------------	------------------------	-------------------------	-----------------------	--------------------------	---	-----------	-----