

| | | |
|---------|-----------------------|-------|
| UNIT | CLOSED CIRCUIT COOLER | |
| MODEL # | ESW4 12-36J18X-SF | SCALE |
| | | NTS |

EVAPCO, INC.

| | | | |
|----------|----------------------|-------|----------|
| DWG. # | WX41218X3612F-DRA-ST | REV | - |
| SERIAL # | | DATE: | 7/2/2026 |

- NOTES:**
- (M)- FAN MOTOR LOCATION
 - HEAVIEST SECTION IS COIL SECTION
 - MPT DENOTES MALE PIPE THREAD
FPT DENOTES FEMALE PIPE THREAD
BFW DENOTES BEVELED FOR WELDING
GVD DENOTES GROOVED
FLG DENOTES FLANGE
 - +UNIT WEIGHT DOES NOT INCLUDE ACCESSORIES (SEE ACCESSORY DRAWINGS)
 - 3/4" [19MM] DIA. MOUNTING HOLES. REFER TO RECOMMENDED STEEL SUPPORT DRAWING
 - MAKE-UP WATER PRESSURE
20 psi MIN [137 kPa], 50 psi MAX [344 kPa]
 - DIMENSIONS LISTED AS FOLLOWS:
ENGLISH FT-IN
[METRIC] [mm]
 - * - APPROXIMATE DIMENSIONS DO NOT USE FOR PRE-FABRICATION OF CONNECTING PIPING
 - COIL CONNECTIONS LOCATED ON FACES B AND D

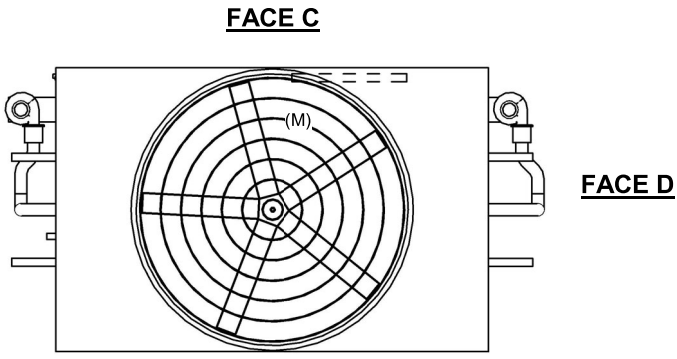

**FACE B
PLAN VIEW**

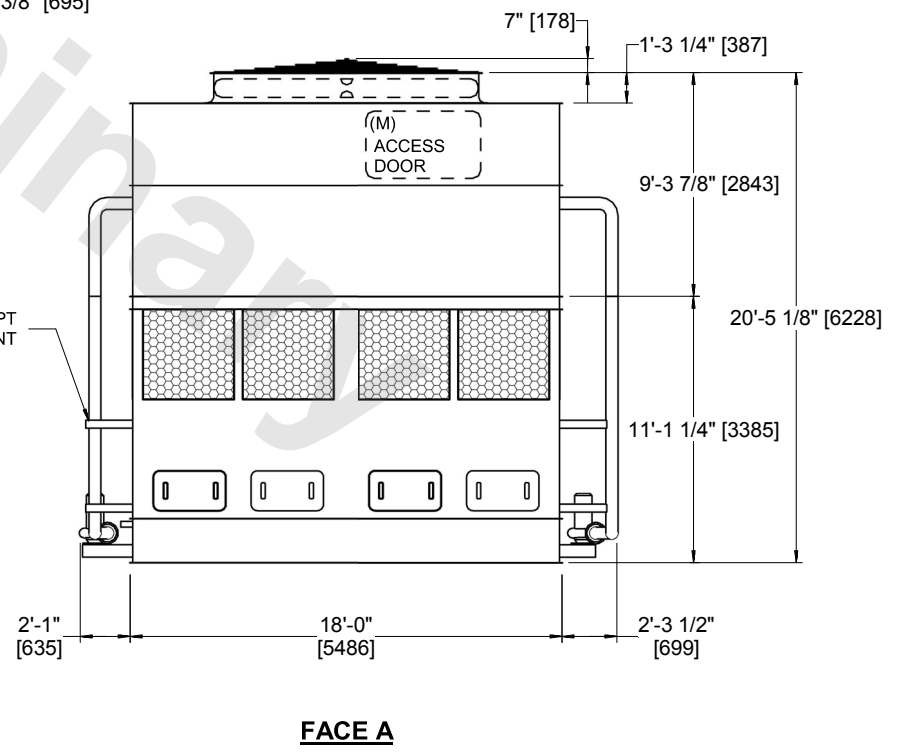
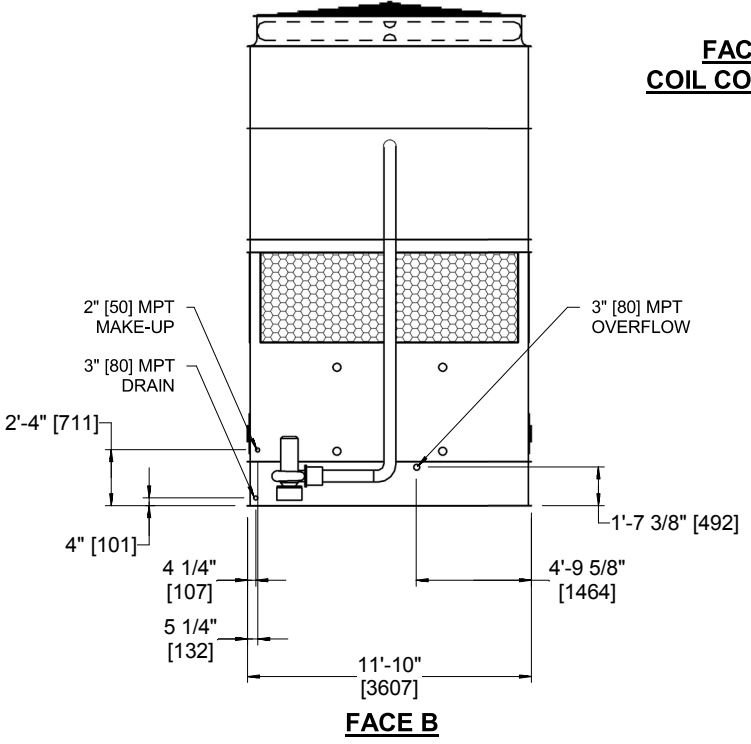
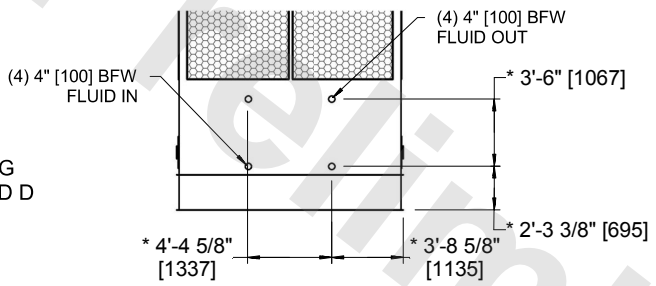

| | | | | | | | | | |
|-----------------|------------------------|------------------|------------------------|-------------------------|------------------------|--------------------------|---|-----------|-----|
| SHIPPING WEIGHT | 36000 lbs+ [16330] kg+ | OPERATING WEIGHT | 52590 lbs+ [23855] kg+ | HEAVIEST SECTION WEIGHT | 28610 lbs+ [12980] kg+ | NO. OF SHIPPING SECTIONS | 2 | DRAWN BY: | AWT |
|-----------------|------------------------|------------------|------------------------|-------------------------|------------------------|--------------------------|---|-----------|-----|