

UNIT	CONDENSER	
MODEL #	ATC-894E	SCALE NTS

# EVAPCO, INC.

DWG. #	C4122408-DRA-ST	REV	-
SERIAL #		DATE:	7/5/2026

**NOTES**

- (M)- FAN MOTOR LOCATION
- MPT DENOTES MALE PIPE THREAD  
FPT DENOTES FEMALE PIPE THREAD  
BFW DENOTES BEVELED FOR WELDING  
GVD DENOTES GROOVED  
FLG DENOTES FLANGE  
PE DENOTES PLAIN END
- +UNIT WEIGHT DOES NOT INCLUDE ACCESSORIES (SEE ACCESSORY DRAWINGS)
- MAKE-UP WATER PRESSURE  
20 psi MIN [137 kPa], 50 psi MAX [344 kPa]
- \*-APPROXIMATE DIMENSIONS DO NOT USE FOR PRE-FABRICATION OF CONNECTING PIPING
- 3/4" [19mm] DIA. MOUNTING HOLES. REFER TO RECOMMENDED STEEL SUPPORT DRAWING.
- DIMENSIONS LISTED AS FOLLOWS:  
ENGLISH FT-IN  
METRIC [mm]

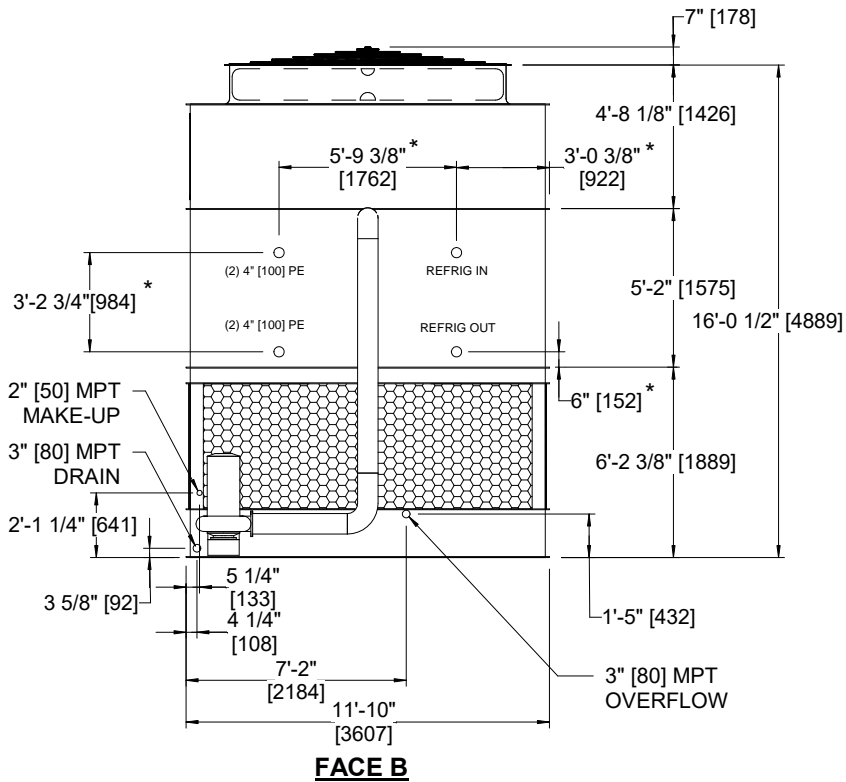

**FACE B  
PLAN VIEW**

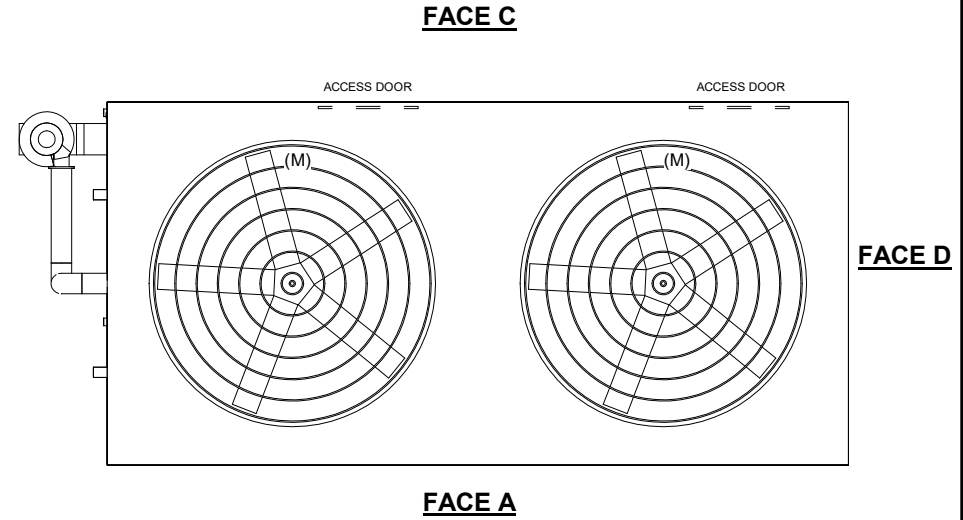

1'-3 1/4" [387]

**FACE A**

2'-10 3/8" [873]

24'-1 3/4" [7360]

**FACE A**

SHIPPING WEIGHT	34080 lbs+ [15460] kg+	OPERATING WEIGHT	46930 lbs+ [21290] kg+	HEAVIEST SECTION WEIGHT	27460 lbs+ [12460] kg+	NO. OF SHIPPING SECTIONS	2	DRAWN BY:	JLG
-----------------	------------------------	------------------	------------------------	-------------------------	------------------------	--------------------------	---	-----------	-----