

# CLOSED CIRCUIT COOLERS

## eco-Air™ Series

**e**nvironmentally

**C**onscious

**O**peration

*Providing Maximum Water Savings*



**EAW-VS**



**EAW-VA**



**EAW-FD**



for LIFE



EAW-Models  
† Mark owned by the Cooling  
Technology Institute



## Get to Know EVAPCO

- The global innovator in heat transfer solutions
- Serving the commercial HVAC, Industrial Refrigeration, Power Generation, and Industrial Processing markets
- Founded in 1976
- Employee-owned
- 26 engineering & manufacturing facilities in 14 countries
- More than 200 sales offices worldwide

## Learn More Now

Visit [evapco.com](http://evapco.com) to download product catalogs, view complete product specifications, and more.

## EVAPCO is more than a name.

It's a pledge to make everyday life easier, more comfortable, more reliable, and more sustainable for people everywhere. How do we fulfill that promise? It's simple.

### **We never stop innovating.**

At EVAPCO, we don't just talk about innovation, it's ingrained in our workflow. Guided by our annually developed R&D plans, we set out to find groundbreaking solutions that transform the way the world works for the better. It's why we have more than 78 active patents worldwide.

### **We craft exceptionally built solutions.**

As an employee-owned company, we take pride in our work. We are proud to be one of the most experienced teams of engineers and craftsmen in the industry. This translates into solutions that are always exceptionally built. EVAPCO has an unwavering commitment to provide "best in class" heat transfer solutions and services.

### **We guarantee performance.**

Every EVAPCO solution is put through rigorous research and testing to ensure maximum efficiency and reliability. But we don't stop there. EVAPCO is an industry leader in independent, third-party performance certifications. These certifications guarantee our performance metrics—so that you can plan your projects with complete peace of mind.

### **We protect the environment.**

Innovation and environmental sustainability go hand-in-hand at EVAPCO. Our industrial heat transfer equipment not only conserves natural resources and helps reduce noise pollution, but also features recycled steel content in construction. EVAPCO's stainless steel units are constructed of panels that contain up to 67% of recycled content, and our galvanized units contain over 79%. From sound reduction to water conservation to chemical elimination, we are continuously developing new technologies that deliver the ultimate operating advantages to our clients—while protecting the planet for every generation to come.



# FULL SPECTRUM GLOBAL SOLUTIONS



EVAPCO provides a full spectrum of global product solutions for the Commercial HVAC, Process Cooling, Industrial Refrigeration and Power Generation markets.

From the smallest factory assembled cooling tower to the largest field erected air-cooled steam condenser, we offer heat transfer products designed to meet the water and energy requirements for any project. We are committed to providing solutions that are energy efficient and conserve water.

## Certified Performance

EVAPCO's eco-Air Series of dry coolers is now CTI certified for thermal performance per Standard 201. The Cooling Technology Institute (CTI) is an independent third-party organization who validates the thermal performance of evaporative and dry heat rejection equipment. CTI Standard 201 was expanded to include dry coolers in 2022. CTI certification provides credibility to EVAPCO's published thermal performance ratings, ensuring every customer has peace of mind when purchasing EVAPCO products.



The eco-Air Series completes our successful eco-family of closed circuit coolers and condensers with water-saving dry and hybrid technology.

As an industry leader in independent, third-party performance certifications, our fully-rated products enable you to operate your cooling systems efficiently and with complete peace of mind.

The eco-Air Series coolers offers unparalleled flexibility in a wide range of capacities, footprints, motor types, and control options.



EC Motor Option



NEMA Motor Option

EC & NEMA Motor Options Available on  
Flat (EAW-FD), V Coil Dry (EAW-VD),  
V Coil Adiabatic (EAW-VA) and V Coil Spray (EAW-VS) Models

# eco-Air Series Design & Construction Features

Available in fully dry, adiabatic and spray designs, the eco-Air Series maximizes heat rejection with minimal or no water use. The eco-Air Series is another chapter in EVAPCO's ongoing commitment to high quality, environmentally friendly products.

## V Coil Models (EAW-VD, EAW-VA, EAW-VS)

### Structure and Casing

- Type 304L Stainless Steel as standard for increased corrosion resistance and longevity
- G-235 galvanized steel available (Dry & Adiabatic Models only)

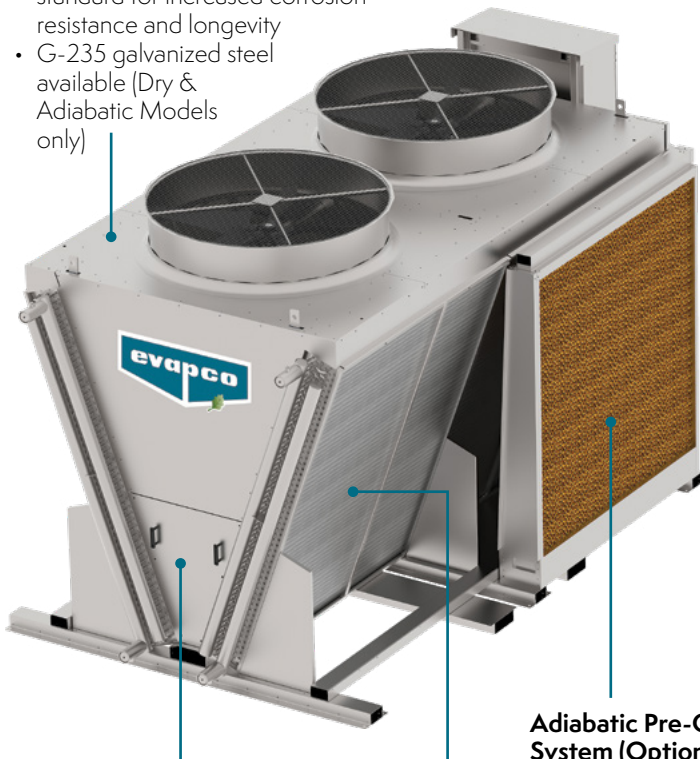

### Inspection Panel (V Coil Models)

- Easily removable for interior inspection and access to coils and fan motors



### Heat Exchanger Coils

- Type 304L Stainless Steel tubes with aluminum fins
- Multiple fin spacings and tube configurations
- Upgraded fin thickness available

### Adiabatic Pre-Cooling System (Optional)

- Wetted pads can be utilized to pre-cool entering air, resulting in greater energy savings, and increased capacity, with minimal water use
- Great for high dry bulb climates and high temperature applications
- Once through design
- No water treatment required
- No cold water basin or pump
- No drift
- V coil models only

- Maximum surface area per footprint
- Optimized coil angle for heat rejection and air flow
- Compact plan area and layout

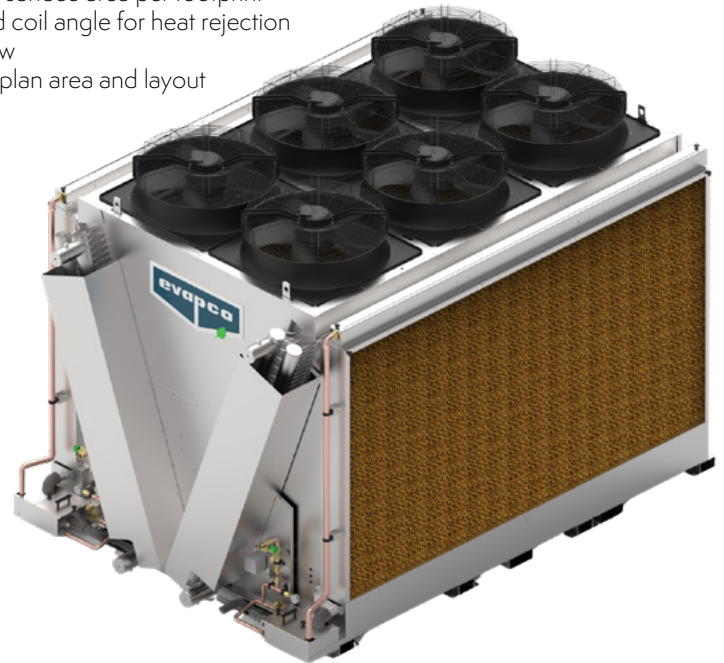

### PuRe-JET™ Pumpless Recirculation System (Optional)

- Minimize water usage during adiabatic operation
- Pumpless design reduces connectivity maintenance, electrical cost, and operational failure risk compared to pumped recirculation systems
- Optional on certain adiabatic units

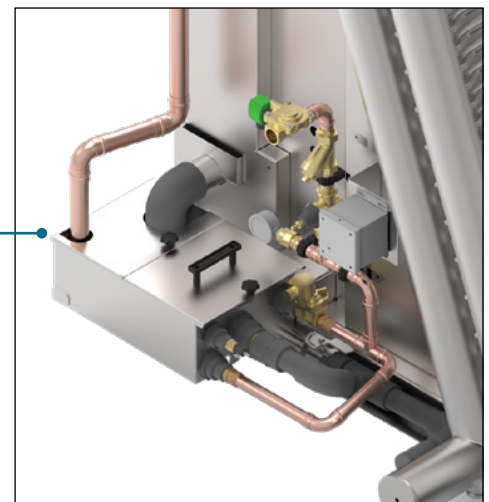

# eco-Air Series Design & Construction Features



## Coil Return Bend Covers

- Protects the coil return bends during handling and operation

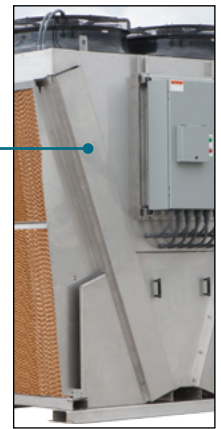

## Internal Step Deck (Optional-V Coil Models)

- Platform and grab rail for access to elevated fan section components (7' 9.75" wide V Coil Models only)

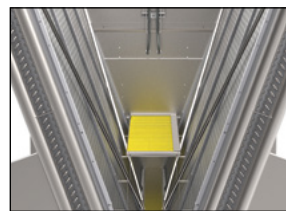

## Spray Assist System (Optional)

- Peak load cooling solution
- Epoxy Coated Fins
- Tangential-flow hollow cone nozzles
- Self-draining copper piping

## Epoxy Coated Fins

- Standard on Spray Models
- Optional on Dry & Adiabatic Models
- Increased corrosion resistance
- No impact on unit capacity

## Advanced Motor Technology – Electronically Commutated (EC) or NEMA fan motor designs



### EC

- High Efficiency
- Zero Maintenance
- Integral Speed Control
- Inherently Low Sound



### NEMA

- Premium efficient direct drive
- Zero maintenance permanently sealed bearings
- VFD ready
- Severe Duty

# eco-Air Series Design & Construction Features

## Flat Coil Models (EAW-FD)

- Low profile design
- Great for elevated installations with bottom airflow clearance

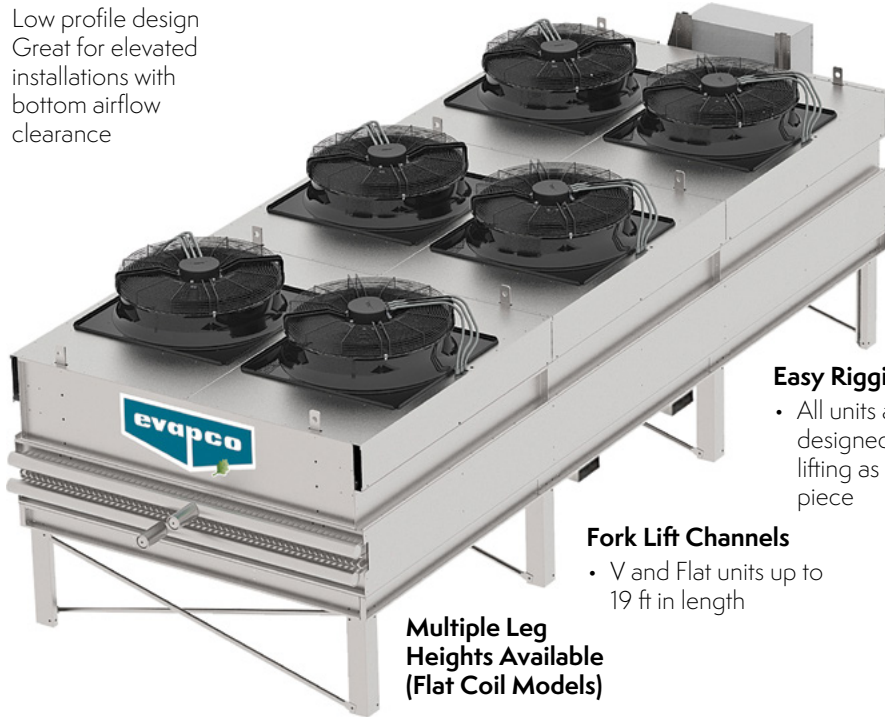

### Easy Rigging

- All units are designed for lifting as one piece

### Fork Lift Channels

- V and Flat units up to 19 ft in length

### Multiple Leg Heights Available (Flat Coil Models)

### Common Terminal Box

- All motors factory wired
- Saves time in the field
- UL Recognized



### Factory Mounted & Wired Controls

- EVAPCO PLC Panel (EC Motors)
- EVAPCO PLC/VFD Panel (NEMA Motors)
- Single point power connection
- UL & cUL Listed
- UL Type 4 enclosure



### Coils Pressurized with Nitrogen

- Limits internal corrosion potential during transport and storage



### IBC Compliant Design

- All standard models meet IBC requirements
- Upgraded designs available for high seismic and wind load areas
- Shake table verified for 1.5 Importance Factor installations

### Warranty

- 2 years complete unit
- 2 years adiabatic pads (if equipped)
- 2 years spray system (if equipped)
- 1 year EVAPCO Controller and other electrical components (if equipped)



eco-Air Series Dry Cooler Thermal Performance is CTI certified per STD-201.



† Mark owned by the Cooling Technology Institute

# Dry Principles of Operation

## eco-Air Series V Coil (EAW-VD) & Flat Coil (EAW-FD) Dry Cooler

Hot Process fluid enters the inlet header connection, shown in red. Heat from the fluid dissipates through the coil tubes surface and out to the fins. Ambient air is drawn in over the coil surface by the fan located at the top of the unit. Heat from the process fluid transfers to the air and discharges to the atmosphere. Cool process fluid exits the unit through the connections shown in blue.

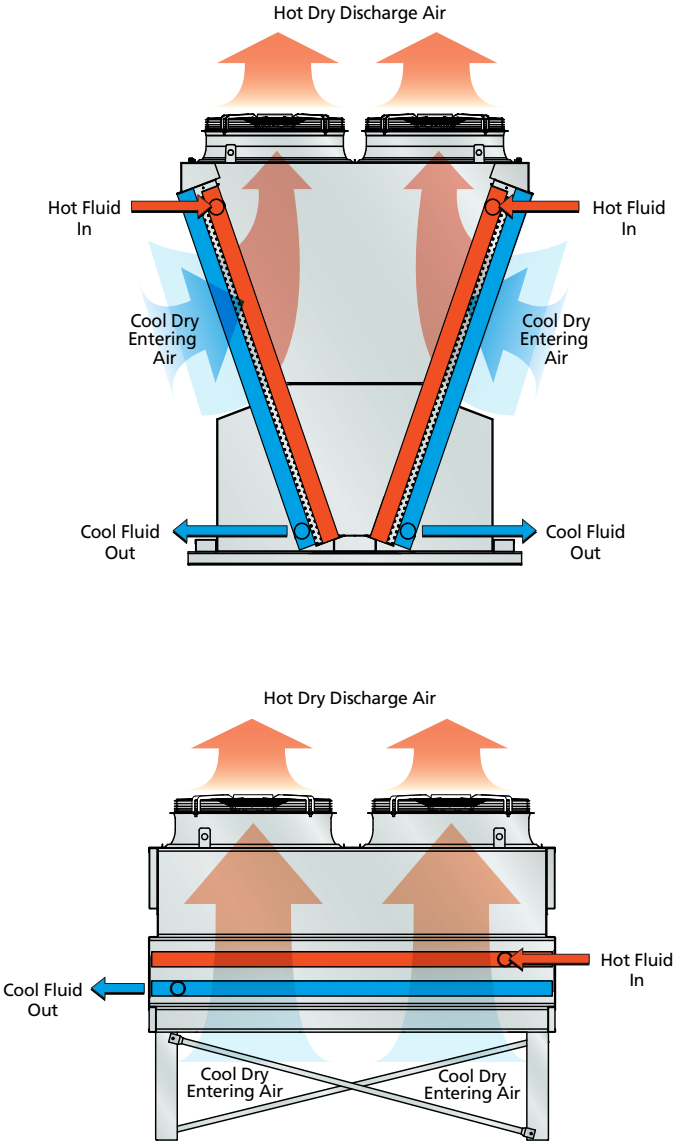

# Adiabatic & Spray Principles of Operation

## eco-Air Series V Coil (EAW-VA) Adiabatic Cooler

Hot process fluid enters the inlet header connection, shown in red. Heat from the process fluid dissipates through the coil tubes surface and out to the fins. The adiabatic system involves fully wetting a fibrous pad located in front of the coil. Ambient air is drawn through the adiabatic pre-cooling pad by the fans located on top of the unit. The air is saturated as it passes through the adiabatic pad, decreasing the dry bulb temperature within a few degrees of the wet bulb temperature. This new air temperature is referred to as the depressed dry bulb. This pre-cooled air is then drawn through the tube and fin surface, offering a substantial increase in heat rejection capability. Heat from the process fluid transfers to the air and discharged to the atmosphere. Cool process fluid exits the unit through the connections shown in blue.

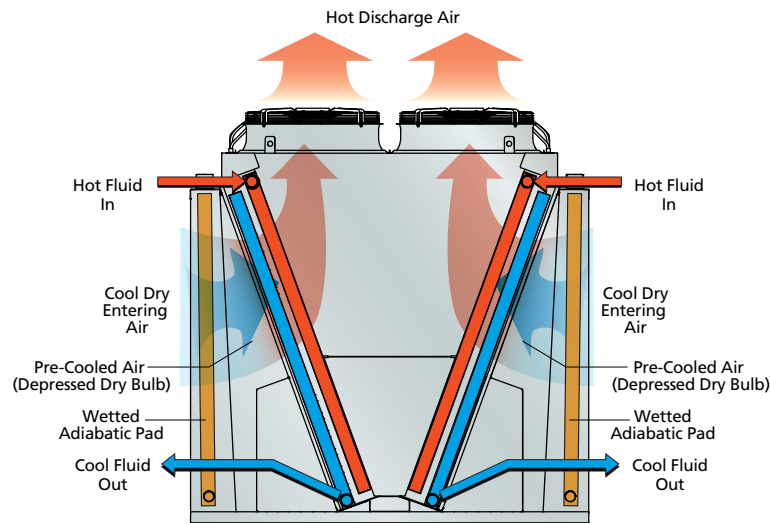

## eco-Air Series V Coil (EAW-VS) Spray Cooler

Hot process fluid enters the inlet header connection, shown in red. Heat from the process fluid dissipates through the coil tubes surface and out to the fins. The unit operates completely dry and modulates fan speed as necessary based on process temperature requirements and ambient conditions. When the unit can no longer maintain leaving water temperature set point in dry mode, the spray assist system is actuated. The spray system nozzles spray water away from the coil, cooling the entering air and increasing the heat rejection capability of the unit. The heat from the process fluid transfers to the cooled air and is discharged to the atmosphere. Cool process fluid exits the unit through the connections shown in blue.

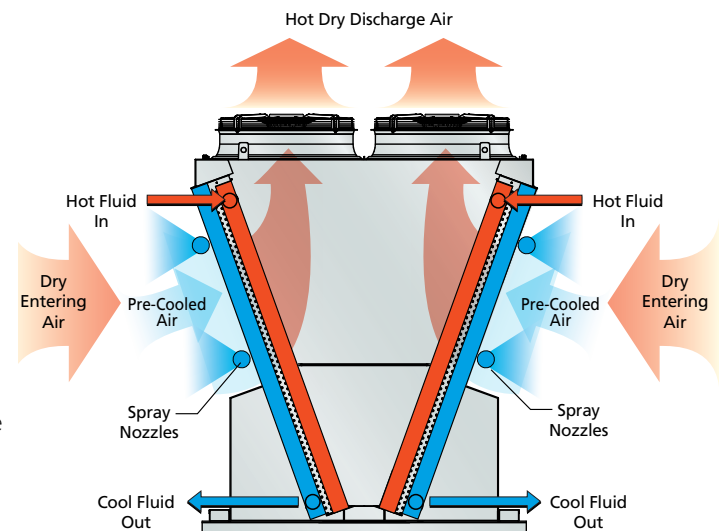

**Spray System Disclaimer:** Although the nozzles spray water away from the coil, the coil and structure will get wet when water is in use. Due to this, the water chemistry guidelines provided in the Installation and Operation Manual should be strictly followed along with the recommended cleaning and maintenance instructions. Evapco also recommends designing the system for a maximum of 200 hours of spray operation per year to help limit the possibility for scale build-up and corrosion.

# Advanced Coil Technology

EVAPCO has long been the industry innovator in heat exchanger coil technology starting in the early 1990's with the introduction of Thermal-Pak® coils which revolutionized the industry. Soon after, EVAPCO became the benchmark in industrial evaporator design, standardizing on stainless steel tubes and aluminum fins. The eco-Air Series coil design builds upon this past success. The coil tube diameter, geometry, and circuiting have been optimized through thousands of hours of theoretical modeling and laboratory testing. The result is optimal heat transfer efficiency with low airside pressure drop and low motor horsepower per ton.

## Coil Design

Through the use of computational fluid dynamics (CFD) modeling software, finite element heat transfer analysis, and proprietary coil performance calculation methods, EVAPCO engineers have identified significant design elements to improve the finned coil performance. The extensive computer modeling has been refined and verified through coil performance evaluation in EVAPCO's state of the art research laboratories.

## Superior Stainless Steel Technology

eco-Air Series dry coolers are constructed with high-grade Type 304L stainless steel tubing and aluminum fins as standard. The stainless steel tubing meets the requirements of ASME B31.5 piping code. The tubing is roll formed and continuously welded, annealed, and tested using an eddy current device.

The round tubing is fit into the aluminum fin plate and hydraulically expanded, this procedure provides more consistent contact between the tube and the fin plate than mechanical expansion. The entire coil is then pressure tested to 110% of design working pressure. Lastly, the coil is dried, evacuated, and charged with low-pressure nitrogen prior to shipment.

EVAPCO's stainless steel tubes are available in 5/8-inch OD. Coils are built in 6, 8, or 10 FPI as standard using a full-collar aluminum fin. Multiple fin thicknesses are available to accommodate a range of industrial applications.

For applications where corrosion of the aluminum fin is a concern, EVAPCO offers pre-coated epoxy fin stock.



# Benefits of eco-Air Series

## Reduced Maintenance

Scaling, corrosion, and water born bacteria concerns are minimized or eliminated with dry and adiabatic cooling equipment. The eco-Air Series reduces the maintenance traditionally associated with fully evaporative systems.

The eco-Air Series adiabatic & spray coolers are designed as a once through systems, meaning no pump and no basin to hold water, reducing the time required for maintenance. Additionally on adiabatic units, the adiabatic pads filter the air before reaching the coil, limiting the exposure of dirt and debris to the tube and fin heat transfer surface.

Both NEMA and EC motor options require zero routine maintenance. There are no bearings to grease, belts to adjust, or fans to pitch and balance.

## Reduced or Eliminated Water Consumption

Compared to traditional evaporative systems, the eco-Air Series will either eliminate or dramatically reduce water consumption. Adiabatic & spray models only use water when the ambient conditions and load require it. Reducing water consumption also reduces the ongoing expenses related with the cooling equipment such as purchasing, treating, and disposing of water.

When the eco-Air Series adiabatic & spray models are used in conjunction with the EVAPCO controls package, water conservation is maximized based on proprietary PLC logic.

## Factory Mounted and Wired Controls

The motors on the eco-Air Series are pre-wired at the factory to UL standards, reducing costs associated with field wiring. As standard, all units are wired to a common terminal box. Adding the EVAPCO controls package allows for both single point power supply and complete capacity control.

## Installation Made Easy

All units are designed for lifting and staging in one piece.

Fork lift channels come standard on all eco-Air Series units up to 19 feet in length. On longer units, reference the eco-Air Series IO&M for lifting requirements from the fan deck lifting lugs.

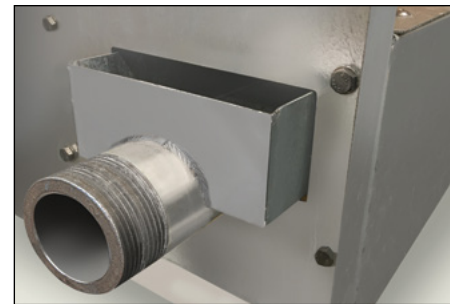

Adiabatic Pad Drip Pan



Zero Maintenance Motors



Factory Wired Fan Motors



Factory Mounted Control Panel

# V Coil Configuration - EC Motor

## Engineering Data

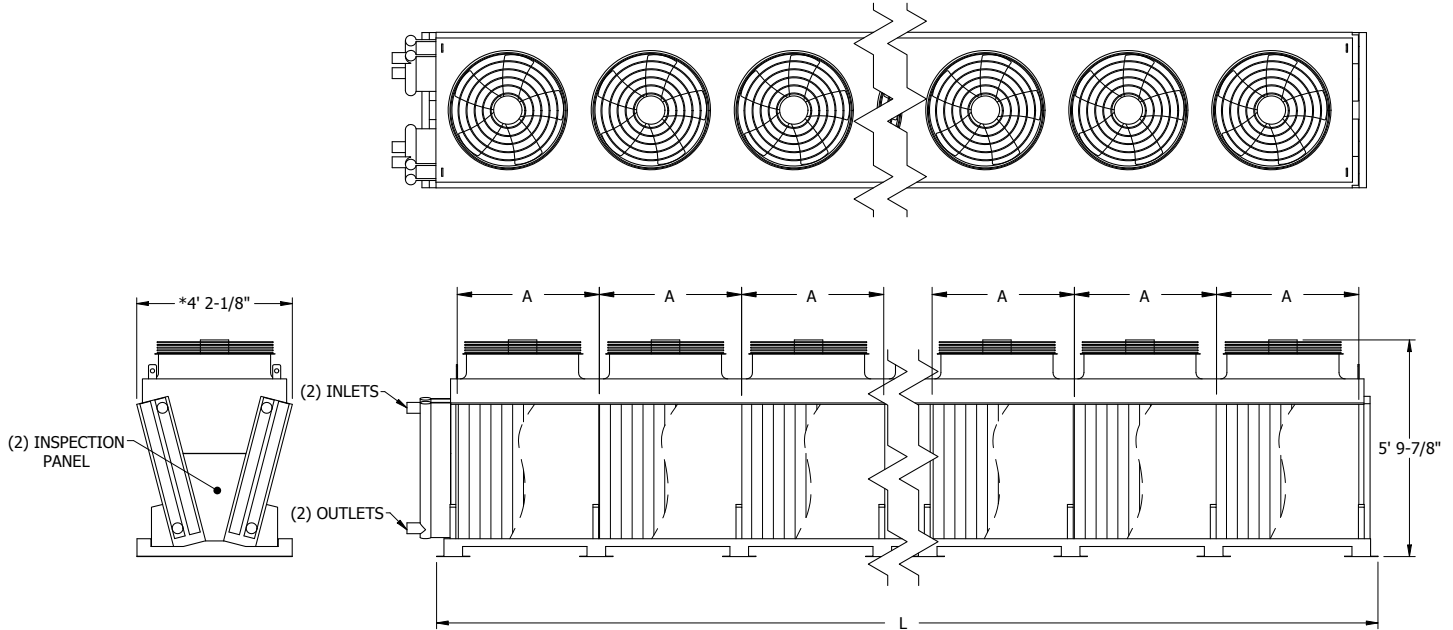

### Single Fan, 4' Wide Models

Model Name	# Fans	Nominal Capacity (MBH)	HP (kW)	Air Volume (CFM)	Unit Length (L)	Coil Volume (gal.)	Shipping Weight (lbs.)	Operating Weight (lbs.)
EAW-VD91S1MA	1	207	4.3 (3.2)	17500	4' - 11-1/4"	31	1550	1810
EAW-VD91S2MA	2	435	8.6 (6.4)	35000	8' - 9-3/8"	48	2560	2960
EAW-VD91S3MA	3	660	12.9 (9.6)	52600	12' - 7-3/8"	65	3530	4070
EAW-VD91S4MA	4	862	17.2 (12.8)	70100	16' - 5-1/2"	81	4560	5240
EAW-VD91S5MA	5	1084	21.5 (16)	87600	20' - 3-1/2"	98	5530	6350
EAW-VD91S6MA	6	1315	25.7 (19.1)	105100	24' - 1-5/8"	115	6470	7430

#### Notes:

\* Adiabatic width: 5' 10-1/8"

A: Two incremental fin lengths available: 3' 10-1/16" or 4' 3-3/16"

Dimensions are subject to change. Do not use for pre-fabrication.

† Nominal Capacity 110°F-100°F at 92°F dry bulb temp.

**Adiabatic capacity:** The adiabatic cooling effect and resulting depressed dry bulb entering the coil depends on the ambient dry bulb and associated relative humidity. Consult your sales representative, EVAPCO marketing, or Spectrum™ selection software for more information.

**Spray Capacity:** The cooling effect resulting from operating the spray system depends on the ambient dry bulb and associated relative humidity entering the coil. Consult your sales representative, EVAPCO marketing or Spectrum™ selection software for more information.

# V Coil Configuration - EC Motor

## Engineering Data

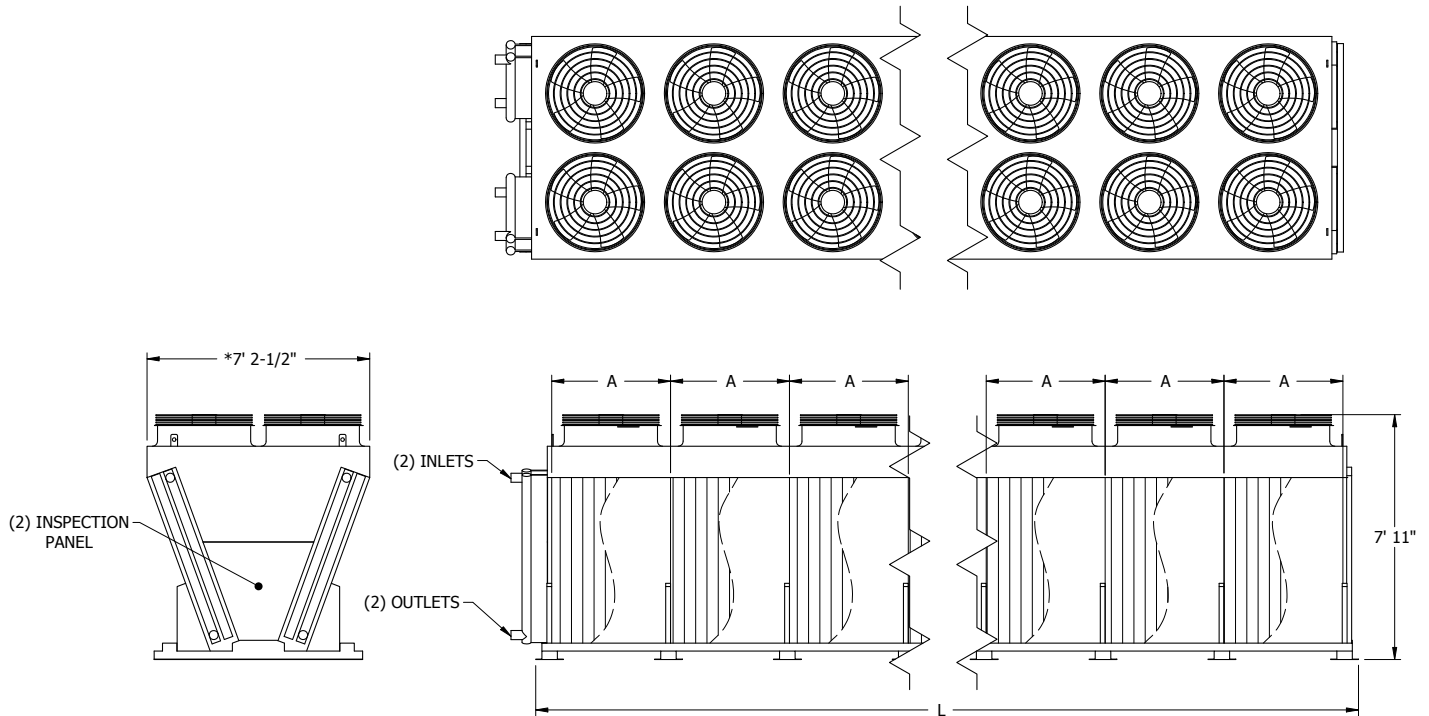

## Twin Fan, 7' Wide Models

Model Name	# Fans	Nominal Capacity (MBH)	HP (kW)	Air Volume (CFM)	Unit Length (L)	Coil Volume (gal.)	Shipping Weight (lbs.)	Operating Weight (lbs.)
EAW-VD9102PJ	2	387	8.6 (6.4)	33100	5' - 4-3/8"	51	2610	3040
EAW-VD9104PJ	4	811	17.2 (12.8)	66100	9' - 7-1/2"	80	4270	4930
EAW-VD9106PJ	6	1221	25.7 (19.1)	99200	13' - 10-3/4"	108	5990	6890
EAW-VD9108PJ	8	1616	34.3 (25.5)	132300	18' - 1-7/8"	137	7690	8830
EAW-VD9110PJ	10	2009	42.9 (31.9)	165300	22' - 5-1/8"	165	9240	10620
EAW-VD9112PJ	12	2433	51.5 (38.3)	198400	26' - 8-1/4"	194	10940	12550
EAW-VD9114PJ	14	2790	60.1 (44.7)	231500	30' - 11-1/2"	222	12620	14470
EAW-VD9116PJ	16	3210	68.7 (51.1)	264500	35' - 2-5/8"	251	14320	16410
EAW-VD9118PJ	18	3424	77.2 (57.5)	297600	39' - 5-7/8"	280	16010	18330
EAW-VD9120PA	20	3575	85.8 (63.9)	316100	39' - 5-7/8"	280	16520	18840

### Notes:

\* Adiabatic width: 8' 9-5/8"

\* Adiabatic with PuRe-JET width: 9' 6-1/2"

A: Two incremental fin lengths available: 3' 10-1/16" or 4' 3-3/16"

Dimensions are subject to change. Do not use for pre-fabrication.

† Nominal Capacity 110°F-100°F at 92°F dry bulb temp.

**Adiabatic capacity:** The adiabatic cooling effect and resulting depressed dry bulb entering the coil depends on the ambient dry bulb and associated relative humidity. Consult your sales representative, EVAPCO marketing, or Spectrum™ selection software for more information.

**Spray Capacity:** The cooling effect resulting from operating the spray system depends on the ambient dry bulb and associated relative humidity entering the coil. Consult your sales representative, EVAPCO marketing or Spectrum™ selection software for more information.

# V Coil Configuration - EC Motor

## Engineering Data

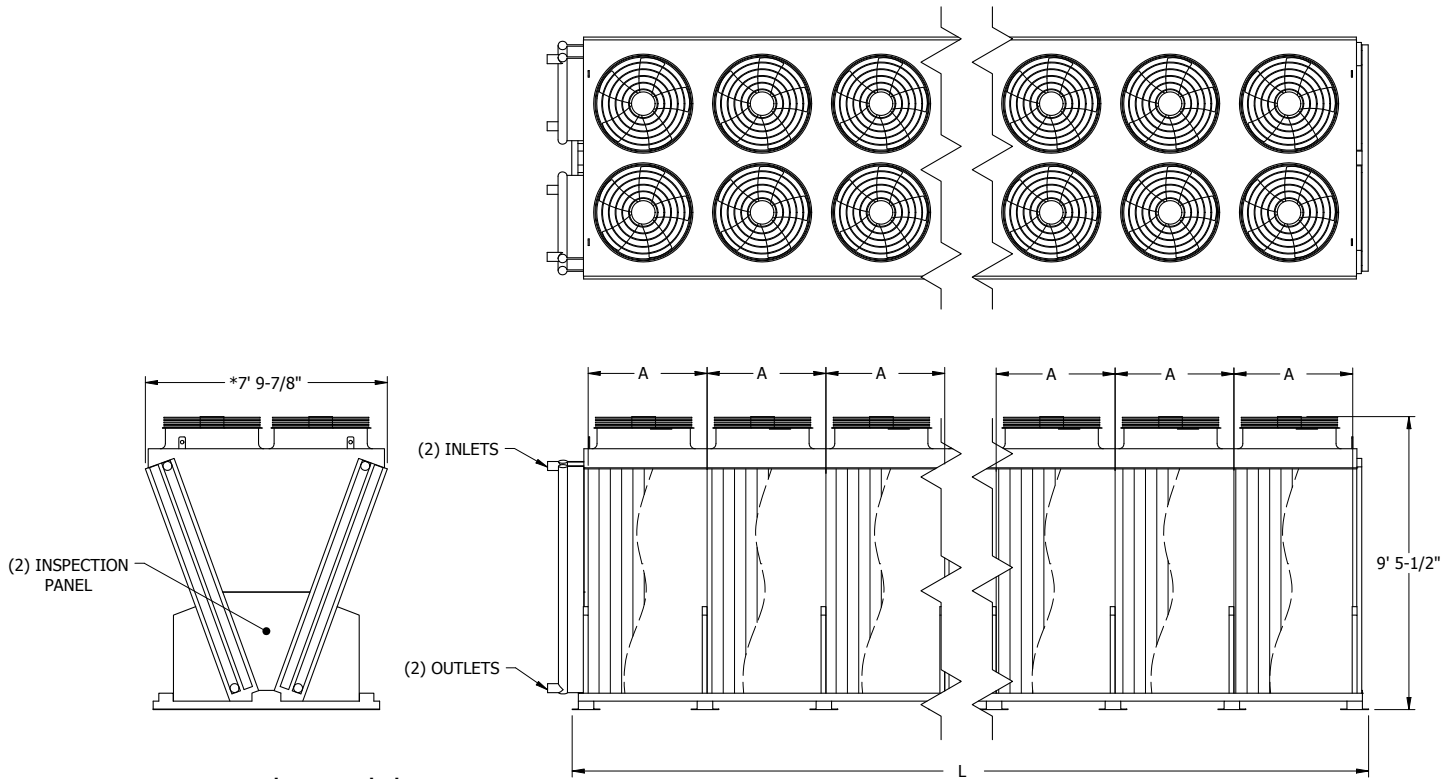

## Twin Fan, 8' Wide Models

Model Name	# Fans	Nominal Capacity (MBH)	HP (kW)	Air Volume (CFM)	Unit Length (L)	Coil Volume (gal.)	Shipping Weight (lbs.)	Operating Weight (lbs.)
EAW-VD9102ZJ	2	447	8.6 (6.4)	36600	5' - 4-3/8"	69	3070	3650
EAW-VD9104ZJ	4	936	17.2 (12.8)	73200	9' - 7-1/2"	107	5010	5910
EAW-VD9106ZJ	6	1418	25.7 (19.1)	109900	13' - 10-3/4"	146	7020	8230
EAW-VD9108ZJ	8	1867	34.3 (25.5)	146500	18' - 1-7/8"	185	9010	10540
EAW-VD9110ZJ	10	2334	42.9 (31.9)	183100	22' - 5-1/8"	223	10840	12690
EAW-VD9112ZJ	12	2825	51.5 (38.3)	219700	26' - 8-1/4"	262	12820	14990
EAW-VD9114ZJ	14	3238	60.1 (44.7)	256300	30' - 11-1/2"	300	14790	17280
EAW-VD9116ZJ	16	3729	68.7 (51.1)	292900	35' - 2-5/8"	339	16770	19580
EAW-VD9118ZJ	18	4217	77.2 (57.5)	329600	39' - 5-7/8"	378	18740	21870
EAW-VD9120ZA	20	4461	85.8 (63.9)	354900	39' - 5-7/8"	378	19280	22410

### Notes:

\* Adiabatic width: 9' 7/8"

\* Adiabatic with PuRe-JET width: 9' 6-1/2"

A: Two incremental fin lengths available: 3' 10-1/16" or 4' 3-3/16"

Dimensions are subject to change. Do not use for pre-fabrication.

† Nominal Capacity 110°F-100°F at 92°F dry bulb temp.

**Adiabatic capacity:** The adiabatic cooling effect and resulting depressed dry bulb entering the coil depends on the ambient dry bulb and associated relative humidity. Consult your sales representative, EVAPCO marketing, or Spectrum™ selection software for more information.

**Spray Capacity:** The cooling effect resulting from operating the spray system depends on the ambient dry bulb and associated relative humidity entering the coil. Consult your sales representative, EVAPCO marketing or Spectrum™ selection software for more information.

# V Coil Configuration - EC Motor

## Engineering Data

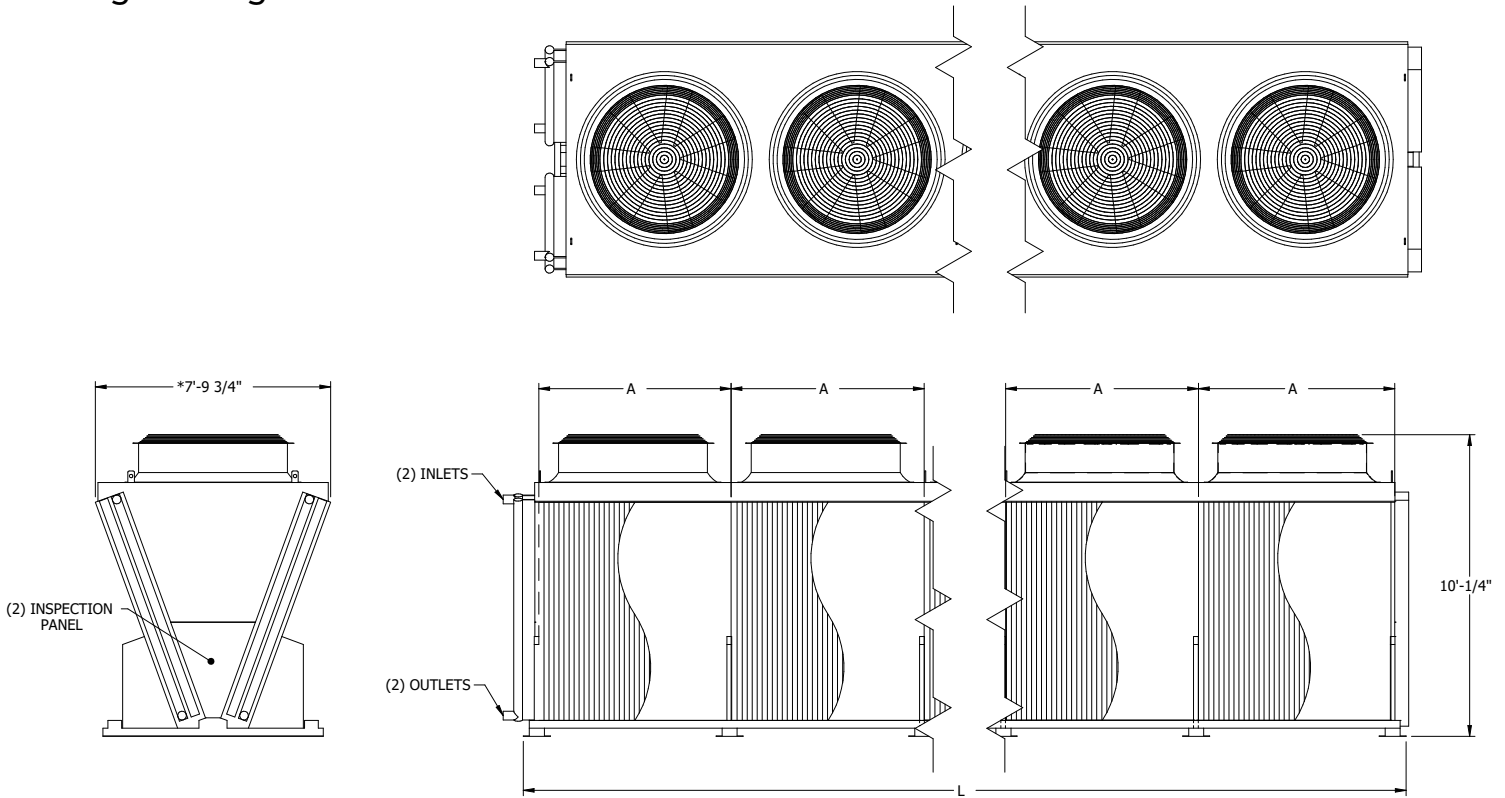

## Single Fan, 8' Wide Models

Model Name	# Fans	Nominal Capacity (MBH)	HP (kW)	Air Volume (CFM)	Unit Length (L)	Coil Volume (gal.)	Shipping Weight (lbs.)	Operating Weight (lbs.)
EAW-VD15S1ZK	1	741	23.2 (17.3)	62700	7' - 6"	88	4890	5690
EAW-VD15S2ZK	2	1520	46.3 (34.6)	125500	13' - 10-3/4"	146	8710	10050
EAW-VD15S3ZK	3	2262	69.9 (51.9)	188200	20' - 3-1/2"	204	12540	14410
EAW-VD15S4ZK	4	3028	92.8 (69.2)	250900	26' - 8-1/4"	262	16180	18590
EAW-VD15S5ZK	5	3735	116 (86.5)	313700	33' - 1"	320	20010	22960
EAW-VD15S6ZK	6	4518	139.2 (103.8)	376400	39' - 5-7/8"	378	23810	27290

- Notes:**
- \* Adiabatic width: 9' 7/8"
  - A: One incremental fin length available: 6' 4-3/4"
  - Dimensions are subject to change. Do not use for pre-fabrication.
  - † Nominal Capacity 110°F-100°F at 92°F dry bulb temp.
- Adiabatic capacity:** The adiabatic cooling effect and resulting depressed dry bulb entering the coil depends on the ambient dry bulb and associated relative humidity. Consult your sales representative, EVAPCO marketing, or Spectrum™ selection software for more information.
- Spray Capacity:** The cooling effect resulting from operating the spray system depends on the ambient dry bulb and associated relative humidity entering the coil. Consult your sales representative, EVAPCO marketing or Spectrum™ selection software for more information.

# V Coil Configuration - NEMA Motor

## Engineering Data

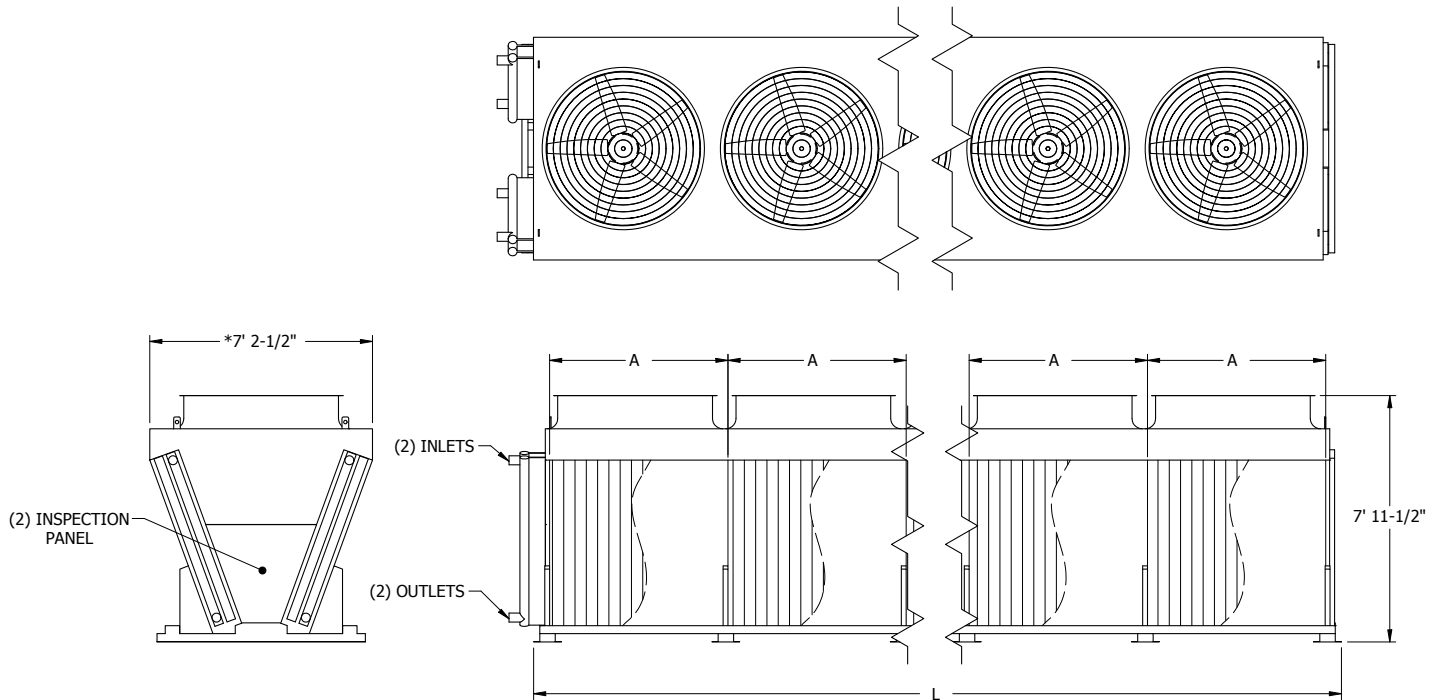

## Single Fan, 7' Wide Models

Model Name	# Fans	Nominal Capacity (MBH)	HP (kW)	Air Volume (CFM)	Unit Length (L)	Coil Volume (gal.)	Shipping Weight (lbs.)	Operating Weight (lbs.)
EAW-VD15S1PI	1	581	10 (7.5)	44500	8' - 9-3/8"	74	4110	4730
EAW-VD15S2PI	2	1159	20 (15)	89100	16' - 5-1/2"	125	7300	8340
EAW-VD15S3PI	3	1744	30 (22.5)	133600	24' - 1-5/8"	177	10350	11820
EAW-VD15S4PI	4	2303	40 (30)	178200	31' - 9-3/4"	228	13520	15420
EAW-VD15S5PI	5	2907	50 (37.5)	222700	39' - 5-7/8"	280	16720	19040
EAW-VD15S6PK	6	3173	60 (45)	249200	39' - 5-7/8"	280	16670	18990

### Notes:

\* Adiabatic width: 8' 9-5/8"

A: Three incremental fin lengths available: 5' 9-1/16", 6' 4-3/4" or 7' 8-1/8"

Dimensions are subject to change. Do not use for pre-fabrication.

† Nominal Capacity 110°F-100°F at 92°F dry bulb temp.

**Adiabatic capacity:** The adiabatic cooling effect and resulting depressed dry bulb entering the coil depends on the ambient dry bulb and associated relative humidity. Consult your sales representative, EVAPCO marketing, or Spectrum™ selection software for more information.

**Spray Capacity:** The cooling effect resulting from operating the spray system depends on the ambient dry bulb and associated relative humidity entering the coil. Consult your sales representative, EVAPCO marketing or Spectrum™ selection software for more information.

# V Coil Configuration - NEMA Motor

## Engineering Data

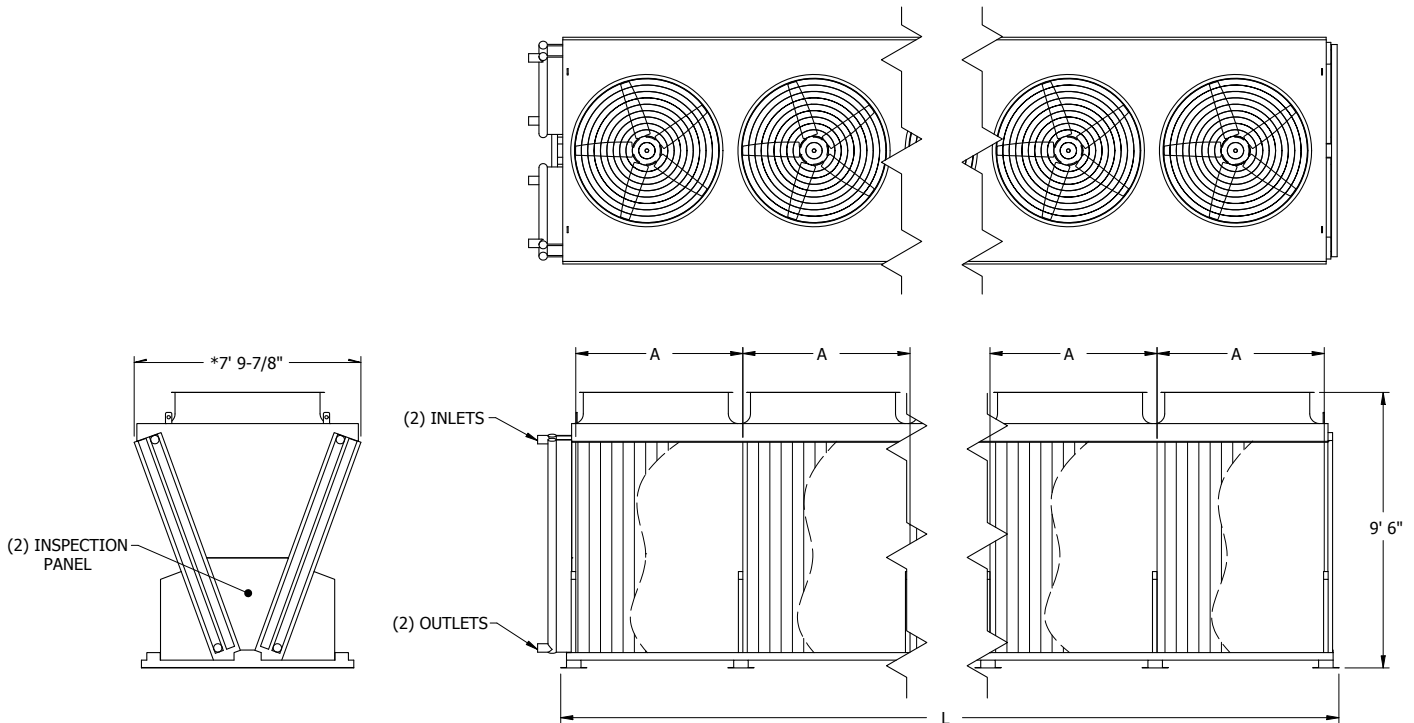

## Single Fan, 8' Wide Models

Model Name	# Fans	Nominal Capacity (MBH)	HP (kW)	Air Volume (CFM)	Unit Length (L)	Coil Volume (gal.)	Shipping Weight (lbs.)	Operating Weight (lbs.)
EAW-VD15S1ZK	1	604	10 (7.5)	46200	7' - 6"	88	4170	4910
EAW-VD15S2ZK	2	1238	20 (15)	92500	13' - 10-3/4"	146	7260	8470
EAW-VD15S3ZK	3	1844	30 (22.5)	138700	20' - 3-1/2"	204	10370	12060
EAW-VD15S4ZK	4	2468	40 (30)	184900	26' - 8-1/4"	262	13280	15450
EAW-VD15S5ZK	5	3047	50 (37.5)	231200	33' - 1"	320	16380	19030
EAW-VD15S6ZK	6	3688	60 (45)	277400	39' - 5-7/8"	378	19460	22590

### Notes:

\* Adiabatic width: 9' 7/8"

A: Two incremental fin lengths available: 5' 9-1/16", 6' 4-3/4" or 7' 8-1/8"

Dimensions are subject to change. Do not use for pre-fabrication.

† Nominal Capacity 110°F-100°F at 92°F dry bulb temp.

**Adiabatic capacity:** The adiabatic cooling effect and resulting depressed dry bulb entering the coil depends on the ambient dry bulb and associated relative humidity. Consult your sales representative, EVAPCO marketing, or Spectrum™ selection software for more information.

**Spray Capacity:** The cooling effect resulting from operating the spray system depends on the ambient dry bulb and associated relative humidity entering the coil. Consult your sales representative, EVAPCO marketing or Spectrum™ selection software for more information.

# Flat Coil Configuration - EC Motor

## Engineering Data

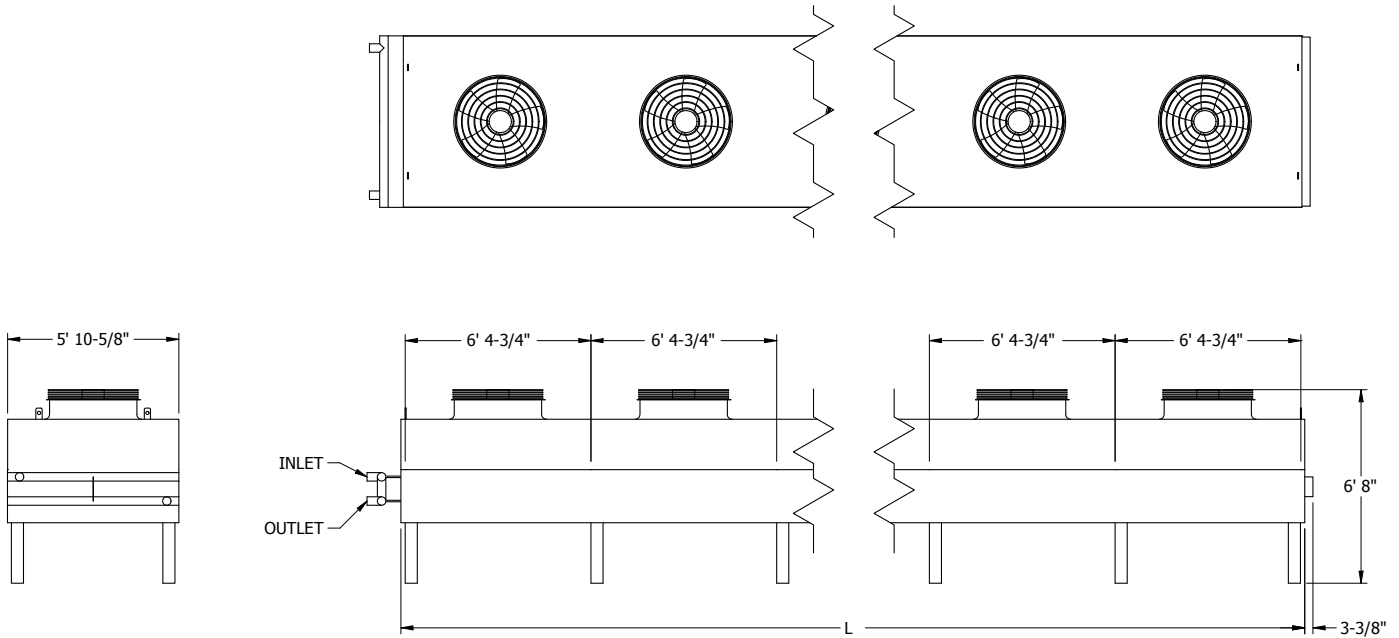

## Single Fan, 6' Wide Models

Model Name	# Fans	Nominal Capacity (MBH)	HP (kW)	Air Volume (CFM)	Unit Length (L)	Coil Volume (gal.)	Shipping Weight (lbs.)	Operating Weight (lbs.)
EAW-FD91S1WK	1	242	4.3 (3.2)	18800	6' - 8-1/8"	33	1720	1990
EAW-FD91S2WK	2	494	8.6 (6.4)	37600	13' - 1"	54	3010	3460
EAW-FD91S3WK	3	739	12.9 (9.6)	56400	19' - 5-3/4"	76	4290	4910
EAW-FD91S4WK	4	985	17.2 (12.8)	75200	25' - 10-1/2"	97	5400	6210
EAW-FD91S5WK	5	1214	21.5 (16)	94100	32' - 3-1/4"	118	6670	7650
EAW-FD91S6WK	6	1470	25.7 (19.1)	112900	38' - 8"	140	7930	9090

### Notes:

Dimensions are subject to change. Do not use for pre-fabrication.

† Nominal Capacity based on 110°F-100°F at 92°F dry bulb temperature.

# Flat Coil Configuration - NEMA Motor

## Engineering Data

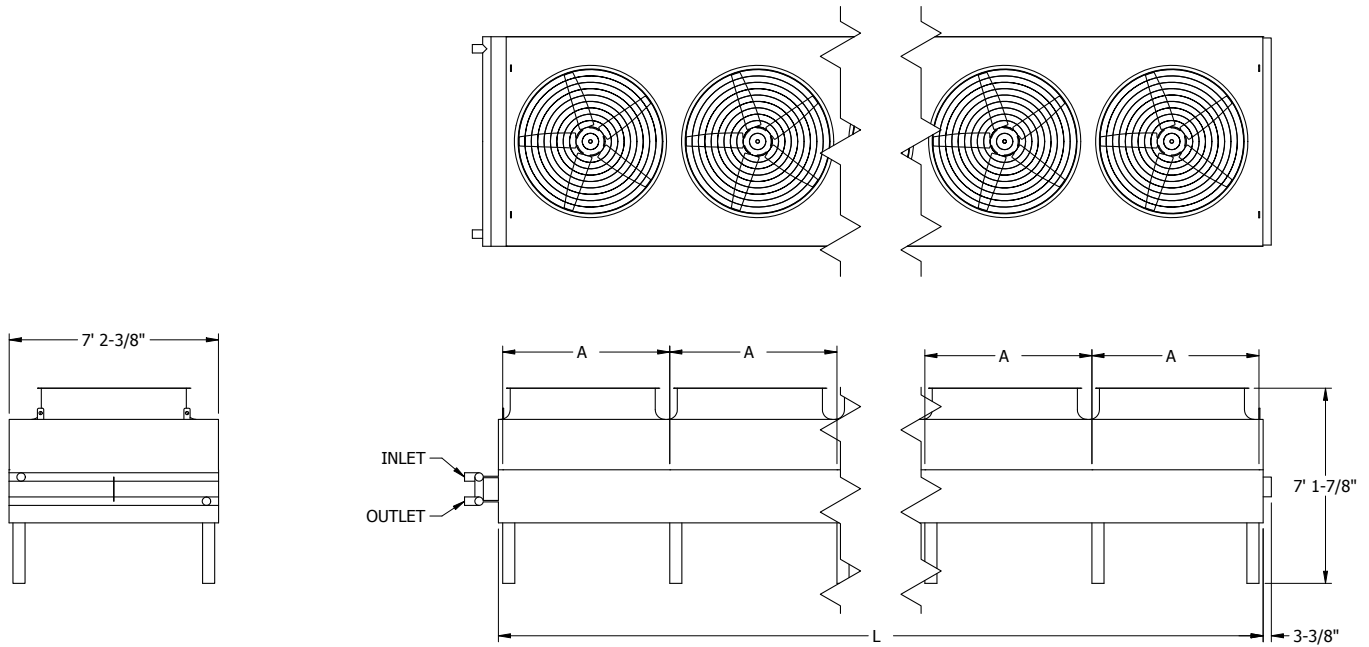

## Single Fan, 7' Wide Models

Model Name	# Fans	Nominal Capacity (MBH)	HP (kW)	Air Volume (CFM)	Unit Length (L)	Coil Volume (gal.)	Shipping Weight (lbs.)	Operating Weight (lbs.)
EAW-FD15S1PB	1	431	10 (7.5)	29300	6' - 1/2"	37	2260	2560
EAW-FD15S2PB	2	860	20 (15)	58600	11' - 9-5/8"	60	3920	4420
EAW-FD15S3PB	3	1294	30 (22.5)	87900	17' - 6-5/8"	83	5610	6300
EAW-FD15S4PB	4	1707	40 (30)	117200	23' - 3-3/4"	106	7110	7990
EAW-FD15S5PB	5	2160	50 (37.5)	146500	29' - 7/8"	129	8790	9860

### Notes:

A: Three incremental fin lengths available: 5' 9-1/16", 6' 4-3/4" or 7' 8-1/8"

Dimensions are subject to change. Do not use for pre-fabrication.

† Nominal Capacity based on 110°F-100°F at 92°F dry bulb temperature.

# Flat Coil Configuration - NEMA Motor

## Engineering Data

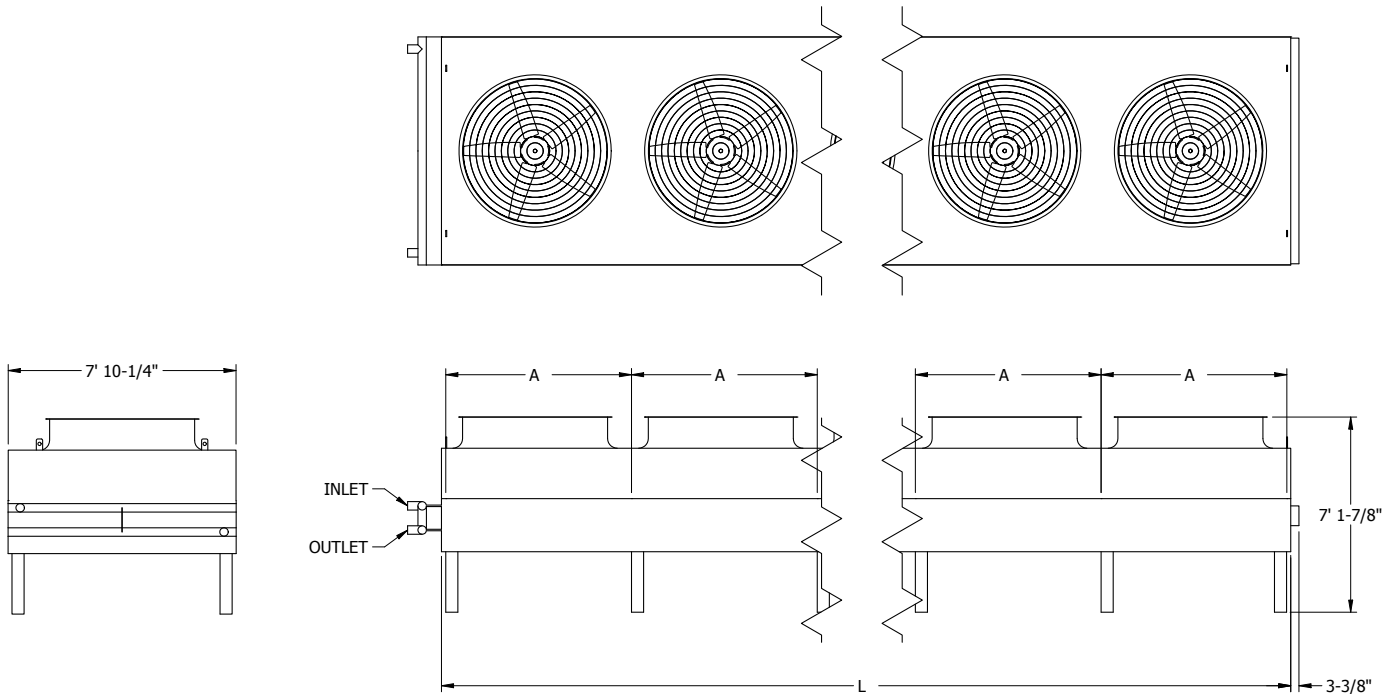

## Single Fan, 8' Wide Models

Model Name	# Fans	Nominal Capacity (MBH)	HP (kW)	Air Volume (CFM)	Unit Length (L)	Coil Volume (gal.)	Shipping Weight (lbs.)	Operating Weight (lbs.)
EAW-FD15S1ZK	1	406	10 (7.5)	34000	6' - 8-1/8"	44	2540	2900
EAW-FD15S2ZK	2	834	20 (15)	67900	13' - 1"	73	4460	5060
EAW-FD15S3ZK	3	1239	30 (22.5)	101900	19' - 5-3/4"	102	6390	7240
EAW-FD15S4ZK	4	1659	40 (30)	135800	25' - 10-1/2"	131	8120	9200
EAW-FD15S5ZK	5	2046	50 (37.5)	169800	32' - 3-1/4"	160	10040	11360
EAW-FD15S6ZK	6	2334	60 (45)	203700	38' - 8"	189	11950	13520

### Notes:

A: Three incremental fin lengths available: 5' 9-1/16", 6' 4-3/4" or 7' 8-1/8"

Dimensions are subject to change.

† Nominal Capacity based on 110°F-100°F at 92°F dry bulb temperature.

# Wiring and Control Options

Factory wiring and control options are available for all eco-Air Series coolers. All wiring follows UL recognized standards. Many eco-Air Series configurations allow for single point power and factory mounted components. Please consult your sales representative or EVAPCO Marketing for job specific details.

**Common Terminal Box** (standard) - All motors wired to a common terminal box located on the end panel opposite coil connections. Factory wiring and design complies with UL Recognized Standards.



**Individual Motor Disconnect Switches** (optional) - Mounted at each fan motor to give the user the ability to isolate individual motor power feeds.



# Wiring and Control Options

**EVAPCO Control Package** – Operating sequence and fan speed control based on real time heat loads and ambient conditions.



- EVAPCO PLC Controller
- Supervisory control system integration
- Fan speed control
  - EC Motor Option: Modbus control of EC fan
  - NEMA Motor Option: Packaged VFD fan speed control with bypass switch
- UL Listed
- UL Type 4 enclosure
- Thermal overload and short circuit protection of each motor
- Operate and fault indicator lights on outside of panel
- Fluid Temperature Sensor (shipped loose)
- Ambient Temperature Sensor
- Rain/Sun Protection Hood (optional)
- Solenoid control of adiabatic pre-cooling system (if equipped)



Water supply solenoid valve arrangement

The EVAPCO Control Package is factory mounted and wired when configuration and shipping limitations allow.



## UL (cUL) Compliance

All Components are  
UL Recognized

The entire unit is UL  
Listed when provided  
with factory mounted  
and wired EVAPCO  
Control Package.



# Structural Steel Support

eco-Air Series Supporting Steel Dimensions			
V Models	Dry & Spray Unit Base Width (W)	Adiabatic Unit Base Width (W)	Adiabatic with PuRe-JET Base Width (W)
4' Wide	4' 2"	5' 10"	-
7' Wide	7' 2-1/2"	8' 9-1/2"	-
8' Wide	7' 3-3/4"	9' 3/4"	9' 6-3/8"
F Models	Base Width (W)	-	-
6' Wide	5' 7-5/16"	-	-
7' Wide	6' 11-1/8"	-	-
8' Wide	7' 7"	-	-

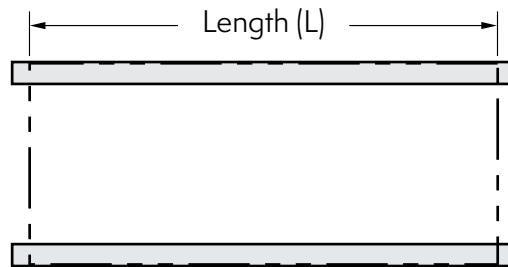
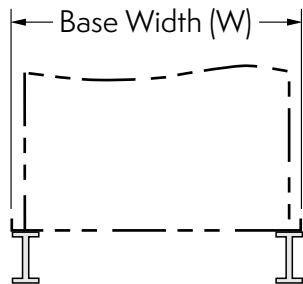

Length as shown on "unit length range (L)" in catalog table

1. These are suggested arrangements for preliminary layout purposes. Consult your EVAPCO representative for factory certified steel support drawings.
2. The recommended support for the eco-Air Series coolers is structural I-beams running the entire length of the unit. Mounting holes, 3/4" in diameter are provided for bolting to the structural steel.
3. Beams should be sized in accordance with accepted structural practices. Maximum deflection of beam under unit to be 1/360 of the unit length, not to exceed 1/2".
5. Beams should be level before setting the unit in place. Do not level the unit by shimming between it and the I-beams.
6. Support beams and Anchor bolts are to be furnished by others.
7. Dimensions, weights and data are subject to change without notice. Refer to the factory certified drawings for exact dimensions.

# EVAPCO Technical Support Services

## EVAPCO Representatives

Your EVAPCO representative is the local expert you can count on to help you with all your HVAC and industrial process needs—from getting quotes, to answering questions, to helping you manage your projects and orders. Find your local representative, by visiting [evapco.com](http://evapco.com) now.

## SPECTRUM™ by EVAPCO

SPECTRUM™ is a new industry leading computer selection program that makes it easy for you to find and optimize the right EVAPCO solutions for every project. Evaluate thermal performance, layout, and energy requirements across units; analyze optional equipment features; and generate complete specifications and unit drawings—all within a friendly and intuitive format. Contact your EVAPCO representative to access SPECTRUM™ now.



## evapco.com

Bookmark [evapco.com](http://evapco.com) for the latest and most complete product information. The website contains a multitude of information and resources including:

- Unit certified drawings
- Steel support drawings
- Scaled isometric views in CAD
- 3-D models in Revit
- Product catalogs
- Rigging instructions
- Operation and maintenance instructions
- White papers
- Videos
- Logo apparel and merchandise

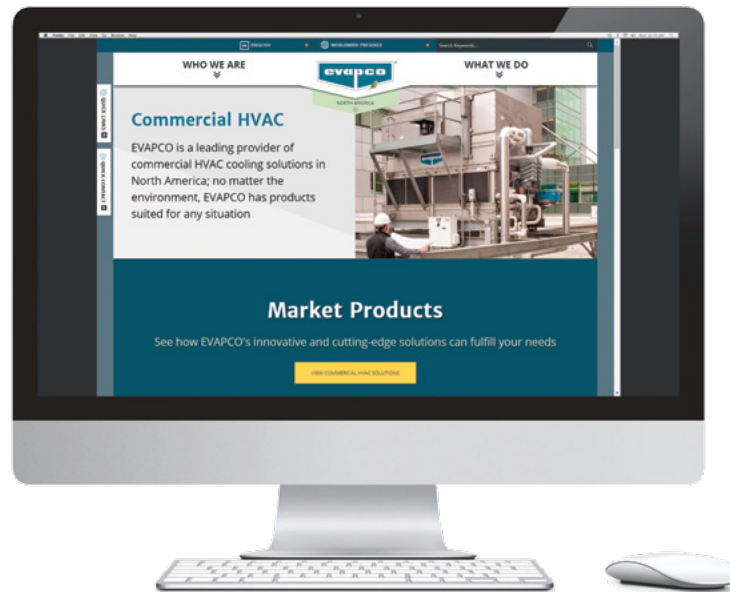

Staying at the forefront of technology is just as important to us as it is you. In addition to developing sustainable solutions in our state-of-the-art research facility, we've also produced analysis tools to assist you in creating a holistic view of your cooling system.

Our powerful software can optimize your design process by **calculating annualized performance data** for your location and site-specific requirements. We can provide design engineers with a comprehensive range of **water and energy consumption** data to help identify the best cooling solution for any project. You can expect the final analysis to include:

FREE COOLING POTENTIAL  
WATER CONSUMPTION  
COOLER POWER  
CHILLER POWER  
PUMP POWER  
AND MORE

**SPECTRUM**  
by **evapco**



# LEADING THE INDUSTRY WITH









- World Headquarters  
Research & Development Center
- EVAPCO Manufacturing Facilities

## EVAPCO, Inc. — World Headquarters & Research / Development Center

P.O. Box 1300 • Westminister, MD 21158 USA  
410.756.2600 • [marketing@evapco.com](mailto:marketing@evapco.com) • [evapco.com](http://evapco.com)

### North America

- EVAPCO, Inc.**  
**World Headquarters**  
Westminister, MD USA  
410.756.2600  
[marketing@evapco.com](mailto:marketing@evapco.com)
- EVAPCO East**  
Taneytown, MD USA
- EVAPCO East**  
Key Building  
Taneytown, MD USA
- EVAPCO Midwest**  
Greenup, IL USA  
217.923.3431  
[evapcomw@evapcomw.com](mailto:evapcomw@evapcomw.com)
- Evapcold Manufacturing**  
Greenup, IL USA
- EVAPCO Newton**  
Newton, IL USA  
618.783.3433  
[evapcomw@evapcomw.com](mailto:evapcomw@evapcomw.com)
- EVAPCO West**  
Madera, CA USA  
559.673.2207  
[contact@evapcowest.com](mailto:contact@evapcowest.com)
- EVAPCO Alcoil, Inc.**  
York, PA USA  
717.347.7500  
[info@evapco-alcoil.com](mailto:info@evapco-alcoil.com)
- EVAPCO Iowa**  
Lake View, IA USA
- EVAPCO Iowa**  
Sales & Engineering  
Medford, MN USA  
507.446.8005  
[evapcomn@evapcomn.com](mailto:evapcomn@evapcomn.com)

- EVAPCO LMP ULC**  
Laval, Quebec, Canada  
450.629.9864  
[info@evapcolmp.ca](mailto:info@evapcolmp.ca)
- EVAPCO Select Technologies, Inc.**  
Belmont, MI USA  
844.785.9506  
[emarketing@evapcoselect.com](mailto:emarketing@evapcoselect.com)
- Refrigeration Vessels & Systems Corporation**  
Bryan, TX USA  
979.778.0095  
[rvs@rvscorp.com](mailto:rvs@rvscorp.com)
- Tower Components, Inc.**  
Ramseur, NC USA  
336.824.2102  
[mail@towercomponentsinc.com](mailto:mail@towercomponentsinc.com)
- EvapTech, Inc.**  
Edwardsville, KS USA  
913.322.5165  
[marketing@evaptech.com](mailto:marketing@evaptech.com)
- EvapTech Gulf Services**  
Houston, TX USA  
281.529.6526  
[angie.montes@evaptech.com](mailto:angie.montes@evaptech.com)
- EVAPCO Dry Cooling, Inc.**  
Bridgewater, NJ USA  
908.379.2665  
[info@evapcodc.com](mailto:info@evapcodc.com)
- EVAPCO Dry Cooling, Inc.**  
Littleton, CO USA  
908.895.3236  
[info@evapcodc.com](mailto:info@evapcodc.com)

### Asia Pacific

- EVAPCO Asia Pacific Headquarters**  
Baoshan Industrial Zone Shanghai, P.R. China  
(86) 21.6687.7786  
[marketing@evapcochina.com](mailto:marketing@evapcochina.com)
- EVAPCO (Shanghai) Refrigeration Equipment Co., Ltd.**  
Baoshan Industrial Zone, Shanghai, P.R. China
- EVAPCO (Beijing) Refrigeration Equipment Co., Ltd.**  
Huairou District, Beijing, P.R. China  
(86) 10.6166.7238  
[marketing@evapcochina.com](mailto:marketing@evapcochina.com)
- EVAPCO Air Cooling Systems (Jiaxing) Company, Ltd.**  
Jiaxing, Zhejiang, P.R. China  
(86) 573.8311.9379  
[info@evapcochina.com](mailto:info@evapcochina.com)
- EVAPCO Australia (Pty.) Ltd.**  
Riverstone, NSW, Australia  
(61) 02.9627.3322  
[sales@evapco.com.au](mailto:sales@evapco.com.au)
- EvapTech (Shanghai) Cooling Tower Co., Ltd.**  
Baoshan District, Shanghai, P.R. China  
Tel: (86) 21.6478.0265
- EvapTech Asia Pacific Sdn. Bhd.**  
Puchong, Selangor, Malaysia  
(60) 3.8070.7255  
[marketing-ap@evaptech.com](mailto:marketing-ap@evaptech.com)

### Europe | Middle East | Africa

- EVAPCO Europe EMENA Headquarters**  
Tongeren-Borgloon, Belgium  
(32) 12.39.50.29  
[evapco.europe@evapco.be](mailto:evapco.europe@evapco.be)
- EVAPCO Europe BV**  
Tongeren-Borgloon, Belgium
- EVAPCO Europe, S.r.l.**  
Milan, Italy  
(39) 02.939.9041  
[evapcoeurope@evapco.it](mailto:evapcoeurope@evapco.it)
- EVAPCO Europe, S.r.l.**  
Sondrio, Italy
- EVAPCO Europe A/S**  
Aabybro, Denmark  
(45) 9824.4999  
[info@evapco.dk](mailto:info@evapco.dk)
- EVAPCO Europe GmbH**  
Meerbusch, Germany  
(49) 2159.69560  
[info@evapco.de](mailto:info@evapco.de)
- EVAPCO Middle East DMCC**  
Dubai, United Arab Emirates  
(971) 56.991.6584  
[info@evapco.ae](mailto:info@evapco.ae)
- Evap Egypt Engineering Industries Co.**  
*A licensed manufacturer of EVAPCO, Inc.*  
Nasr City, Cairo, Egypt  
(20) 10.054.32.198  
[evapco@tiba-group.com](mailto:evapco@tiba-group.com)
- EVAPCO S.A. (Pty.) Ltd.**  
*A licensed manufacturer of EVAPCO, Inc.*  
Isando, South Africa  
(27) 11.392.6630  
[evapco@evapco.co.za](mailto:evapco@evapco.co.za)

### South America

- EVAPCO Brasil**  
*Equipamentos Industriais Ltda.*  
Sorocaba, São Paulo, Brazil  
(55) 11.5681.2000  
[vendas@evapco.com.br](mailto:vendas@evapco.com.br)
- FanTR Technology Resources**  
Sorocaba, São Paulo, Brazil  
(55) 11.4025.1670  
[fantr@fantr.com](mailto:fantr@fantr.com)