



for LIFE

COOLING TOWERS



AT ATLAS



† Mark owned by the Cooling Technology Institute

MODULAR ADVANCED TECHNOLOGY (AT) SERIES
Large, Energy Efficient, Modular, Counterflow Cooling Towers

ABOUT EVAPCO



EVAPCO for LIFE

EVAPCO is more than a name. We are the global innovator in heat transfer solutions for the commercial HVAC, industrial refrigeration, power and industrial process markets. We pledge to make everyday life easier, more comfortable, more reliable and more sustainable for people everywhere.

OUR COMMITMENT

We never stop innovating. We set out to find groundbreaking solutions that transform the way the world works for the better. It's why we have more than 50 active U.S. patents and nearly 200 foreign counterparts. We also guarantee performance and put every solution through rigorous research and testing to ensure maximum efficiency and reliability.



PROTECTING THE ENVIRONMENT

Innovation and environmental sustainability go hand-in-hand at EVAPCO. Our industrial heat transfer equipment not only conserves natural resources and helps reduce noise pollution, but also features recycled steel content in construction. Our stainless steel units are constructed of panels that contain up to 67% of recycled content and our galvanized units contain over 79%. From sound reduction to water conservation to chemical elimination, we are developing new technologies that deliver ultimate operating advantages to our clients while protecting the planet for every generation to come.

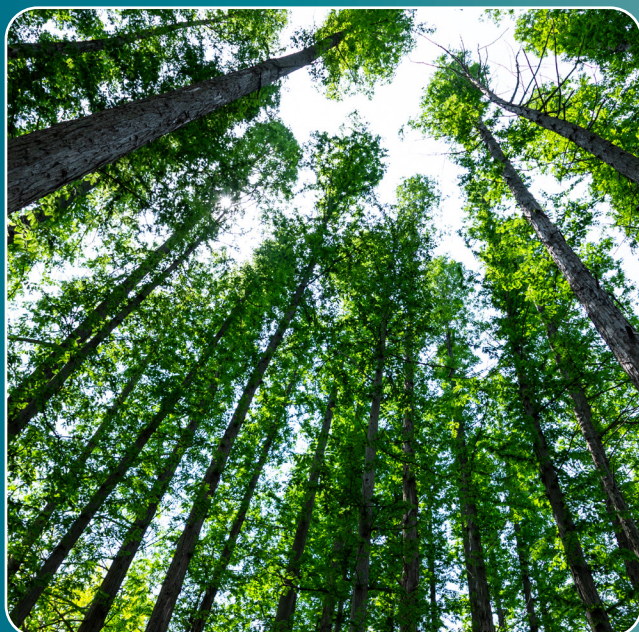

ATLAS APPLICATIONS

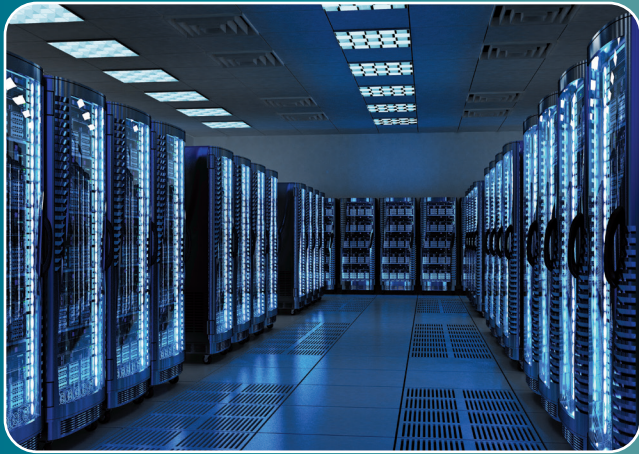

DATA CENTERS



INDUSTRIAL PROCESS



CENTRAL PLANTS

To ensure 100% **reliability** for the high demands of critical cooling applications, the Atlas is highly engineered with quality components and manufactured to exacting standards. The **durable** materials of construction ensure the **longevity** expected of EVAPCO products. The cooling towers are designed in large modules for ease of installation and to reduce required field assembly labor. As the most energy efficient modular cooling tower on the market, the Atlas is unmatched in CTI Certified capacity per cell!

The AT Atlas

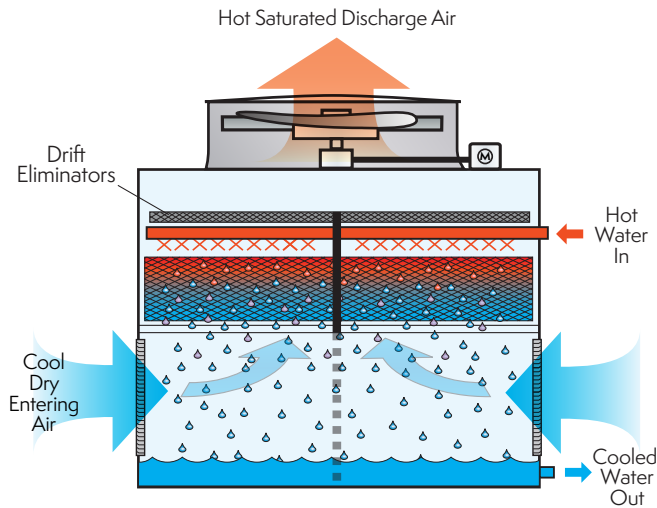

PRINCIPLE OF OPERATION

This cutaway graphic of the AT Atlas illustrates the basic functionality of our modular, induced draft, counterflow cooling tower. Hot water from the heat source is pumped to the water distribution system at the top of the tower. The water is distributed over the wet deck fill by means of our EvapJet™ nozzles. Simultaneously, air is drawn in through the air inlet louvers at the base of the tower on all four sides and travels upward through the wet deck fill opposite the water flow. The cooled water drains to the basin at the bottom of the tower and is returned to the heat source.

FACTORY ASSEMBLED LEAD TIMES

- The Atlas arrives to site preassembled in modules and installs in a fraction of the time of field erected solutions.
- Reduced overall piping and electrical connections compared to projects with traditional factory assembled cooling towers.
- Site installation supervision available from factory-trained technicians.

FIELD-ERECTED CAPABILITIES

Up to **60% more cooling capacity** per cell*



Up to **40% less fan power** per ton of cooling*

* When compared to other factory-assembled single cell towers.

ROBUST DESIGN & MATERIALS

Built with industrial-grade materials and engineered to withstand the demands of HVAC and industrial applications:

- Heavy-gauge steel structure, galvanized or stainless steel
- 5-year mechanical component warranty
- Energy-efficient PVC heat exchange fill media
- Standard motor outside airstream

CERTIFIED THERMAL PERFORMANCE



† Mark owned by the Cooling Technology Institute



HIGH-EFFICIENCY DRIFT ELIMINATORS



- EVAPCO's extremely efficient drift eliminator system removes entrained water droplets from the air stream, limiting the drift rate down to 0.0005% of the recirculating water rate.
- Constructed of inert PVC, which effectively eliminates corrosion of these vital components. They are assembled in sections to facilitate easy removal for inspection of the water distribution system.

EVAPAK® FILL

- EVAPAK® fill is specially designed to induce a highly turbulent mix of air and water for superior heat transfer. Special drainage tips allow high water loadings without excessive pressure drops.
- The bottom support of the fill section, combined with the unique way in which EVAPAK's cross-fluted sheets are bonded together, greatly enhances the fill's structural integrity, making it usable as a working platform for internal access to the fan and drive system.
- Low fouling fill available for alternate water qualities. Contact an EVAPCO representative for more information.

WATER & SIGHT TIGHT (WST) AIR INLET LOUVERS

- Easily removable for access
- Framed in same material as tower basin
- Improved design to keep sunlight out—preventing biological growth
- Keeps water in while keeping dirt and debris out



CLEAN PAN SLOPED BASIN DESIGN

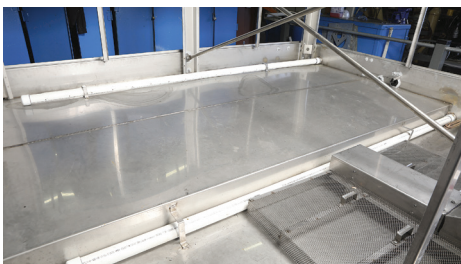

- Designed to completely drain the cold water basin
- Helps prevent buildup of sediment and biological film
- Eliminates standing water after draindown

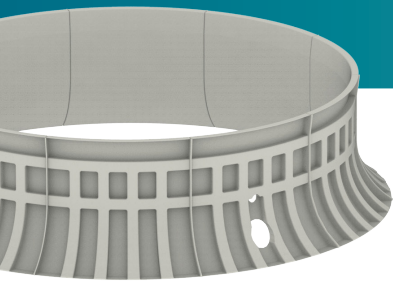

Exclusive 5 Year Motor and Drive Warranty

MECHANICAL EQUIPMENT

EVAPCO provides fans, gearboxes, driveshafts and motors from a select group of equipment suppliers specializing in cooling tower products. These relationships ensure a high quality product that can withstand the harsh cooling tower environment while also producing the airflow required for peak thermal performance.

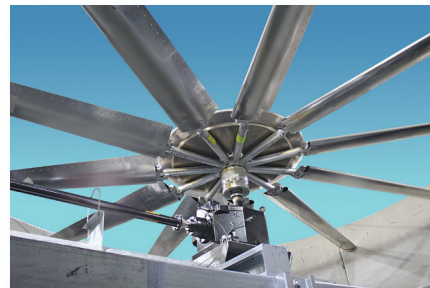
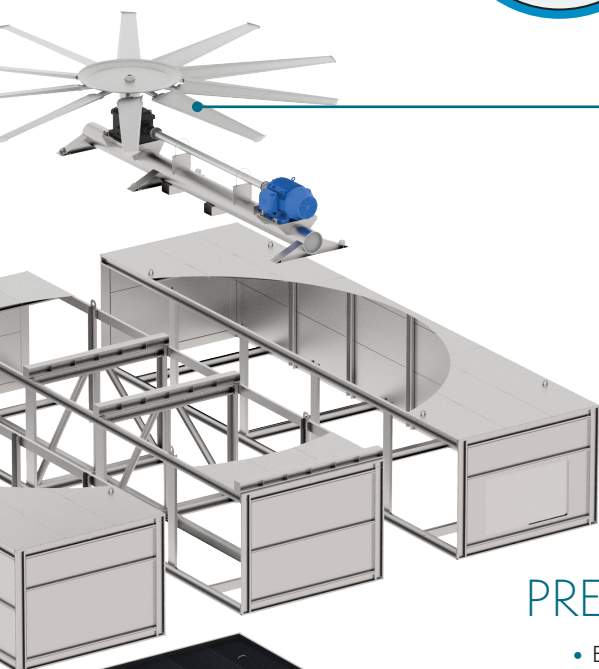

PRESSURIZED WATER DISTRIBUTION SYSTEM

- Evapjet™ nozzles provide thermal performance gain
- Non-corrosive PVC construction
- Large orifice nozzles prevent clogging and are threaded for easy removal and positive positioning
- Each nozzle provides a large uniform spray pattern

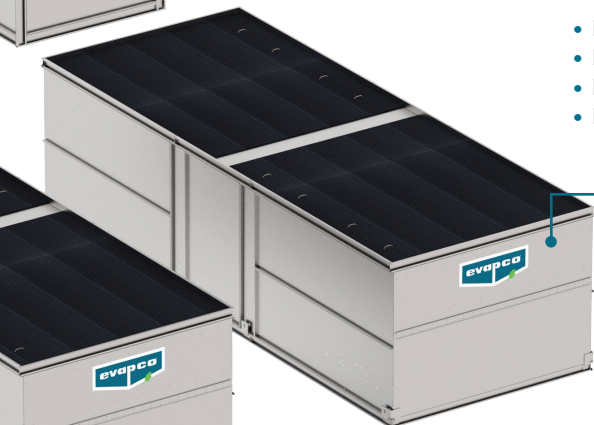

ACCESS

- Removable louvers offer 360 degree basin access for easy inspection and maintenance

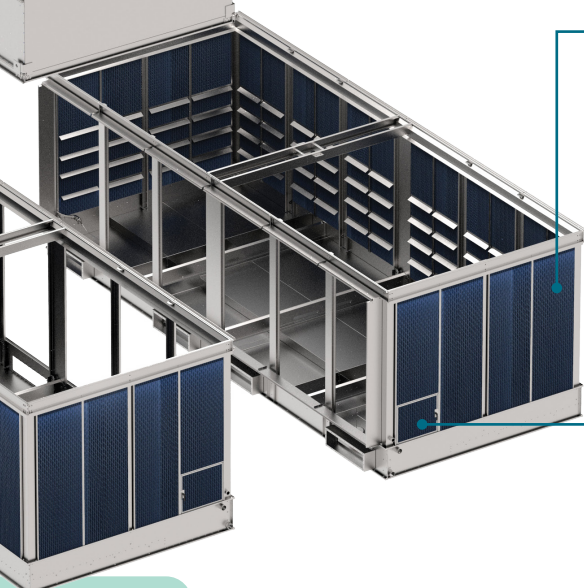

LOUVER ACCESS DOOR

- Hinged access panel with quick release mechanism
- Allows easy access to perform routine maintenance and inspection of the makeup assembly, strainer screen and basin



Engineering Data & Dimensions

AT 124-4N30-EV to 124-5T30- EV

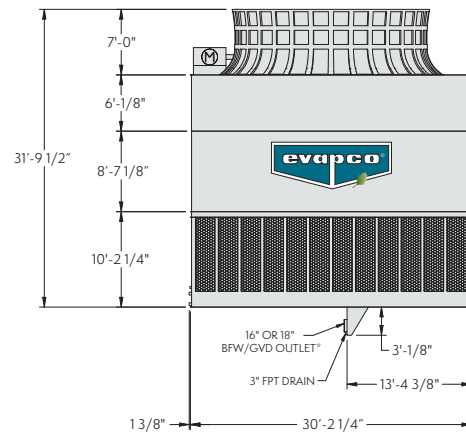
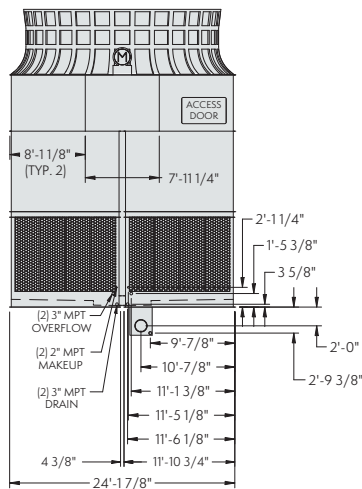
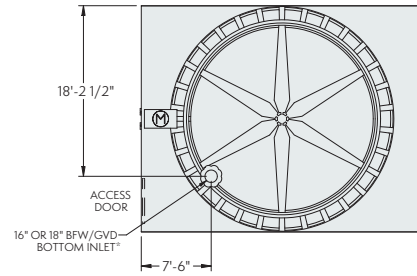

* CONNECTIONS ARE SIZED BASED ON FLOW RATES

Model No.	Nominal Tonnage	Fan Motor (HP)	Air Flow (CFM)	Weights (LBS)		
				Operating	Heaviest Section	Shipping
AT 124-4N30-EV	1,515	40	310,000	93,780	12,320	67,250
AT 124-4O30-EV	1,611	50	333,000	94,120	12,320	67,590
AT 124-4P30-EV	1,748	60	352,500	94,420	12,320	67,890
AT 124-4Q30-EV	1,855	75	378,600	94,370	12,320	67,840
AT 124-4R30-EV	2,081	100	414,000	94,630	12,320	68,100
AT 124-4S30-EV	2,234	125	443,900	95,540	12,320	69,010
AT 124-4T30-EV	2,380	150	469,700	96,100	12,320	69,570
AT 124-5N30-EV	1,528	40	305,400	95,540	13,200	69,010
AT 124-5O30-EV	1,619	50	328,100	95,880	13,200	69,350
AT 124-5P30-EV	1,753	60	347,400	96,180	13,200	69,650
AT 124-5Q30-EV	1,854	75	373,100	96,130	13,200	69,600
AT 124-5R30-EV	2,095	100	407,700	96,390	13,200	69,860
AT 124-5S30-EV	2,220	125	437,500	97,300	13,200	70,770
AT 124-5T30-EV	2,356	150	463,000	97,860	13,200	71,330
SLSF Addition				2,100		2,100

- NOTES:**
- (1) An adequately sized bleed line must be installed in the cooling tower system to prevent buildup of impurities in the recirculated water.
 - (2) Do not use catalog drawings for certified prints. Dimensions and weights are subject to change.
 - (3) Adequate spacing must be allowed for access to the cooling tower. Refer to EVAPCO's Equipment Layout Manual.
 - (4) Nominal tonnage is based on 3 gpm per ton at 95° F entering water temperature, 85° F leaving water temperature, and 78° F wet-bulb temperature.
 - (5) Models with the "-N" suffix have up to a 3% nominal tonnage increase.
 - (6) SLSF adds 33-1/8" to unit overall height.

Engineering Data & Dimensions

AT 248-4N30-EV to 248-5T30-EV

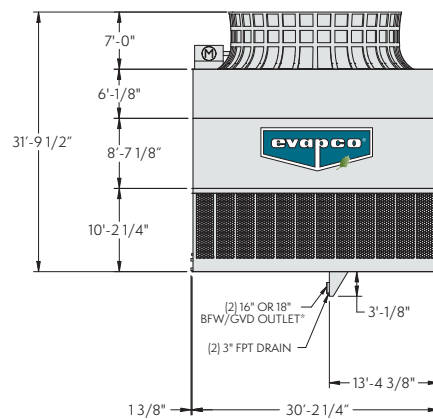
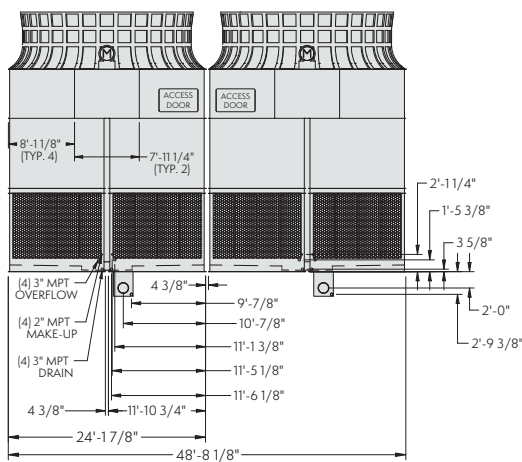
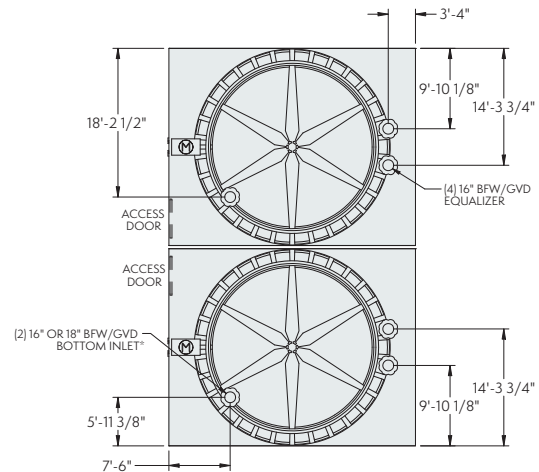

* CONNECTIONS ARE SIZED BASED ON FLOW RATES

Model No.	Nominal Tonnage	Fan Motor (HP)	Air Flow (CFM)	Weights (LBS)		
				Operating	Heaviest Section	Shipping
AT 248-4N30-EV	2,933	(2)40	605,200	187,560	12,320	134,500
AT 248-4O30-EV	3,118	(2)50	650,300	188,240	12,320	135,180
AT 248-4P30-EV	3,387	(2)60	688,400	188,840	12,320	135,780
AT 248-4Q30-EV	3,595	(2)75	739,400	188,740	12,320	135,680
AT 248-4R30-EV	4,037	(2)100	808,700	189,260	12,320	136,200
AT 248-4S30-EV	4,335	(2)125	867,300	191,080	12,320	138,020
AT 248-4T30-EV	4,621	(2)150	917,800	192,200	12,320	139,140
AT 248-5N30-EV	2,958	(2)40	596,300	191,080	13,200	138,020
AT 248-5O30-EV	3,140	(2)50	640,700	191,760	13,200	138,700
AT 248-5P30-EV	3,400	(2)60	678,300	192,360	13,200	139,300
AT 248-5Q30-EV	3,600	(2)75	728,600	192,260	13,200	139,200
AT 248-5R30-EV	4,072	(2)100	796,400	192,780	13,200	139,720
AT 248-5S30-EV	4,315	(2)125	854,700	194,600	13,200	141,540
AT 248-5T30-EV	4,583	(2)150	904,500	195,720	13,200	142,660
SLSF Addition				4,200		4,200

- NOTES:**
- (1) An adequately sized bleed line must be installed in the cooling tower system to prevent buildup of impurities in the recirculated water.
 - (2) Do not use catalog drawings for certified prints. Dimensions and weights are subject to change.
 - (3) Adequate spacing must be allowed for access to the cooling tower. Refer to EVAPCO's Equipment Layout Manual.
 - (4) Nominal tonnage is based on 3 gpm per ton at 95° F entering water temperature, 85° F leaving water temperature, and 78° F wet-bulb temperature.
 - (5) Models with the "-N" suffix have up to a 3% nominal tonnage increase.
 - (6) SLSF adds 33-1/8" to unit overall height.

Engineering Data & Dimensions

AT 224-4N60-EV to AT 224-5T60-EV

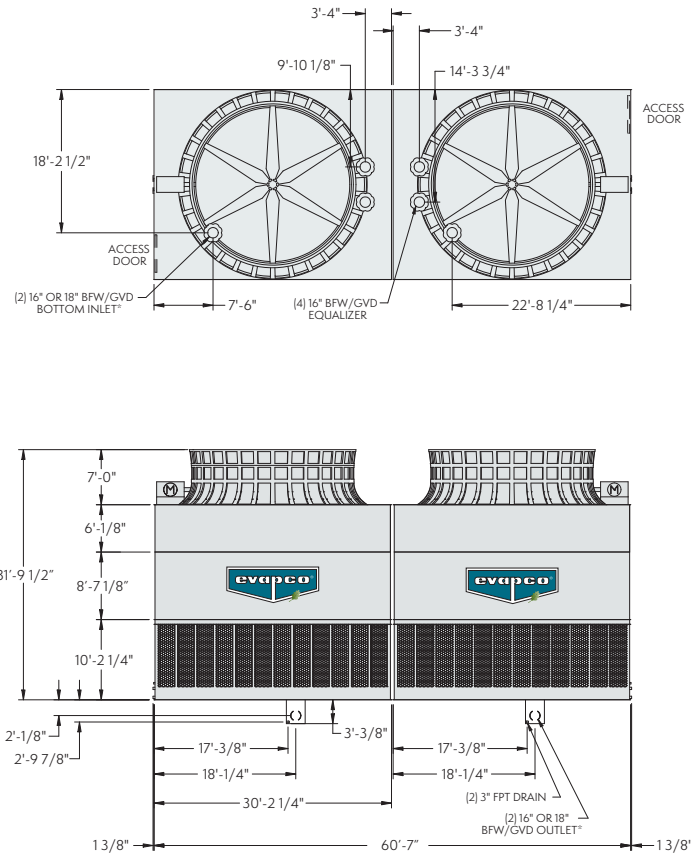

* - CONNECTIONS ARE SIZED BASED ON FLOW RATES

Model No.	Nominal Tonnage	Fan Motor (HP)	Air Flow (CFM)	Weights (LBS)		
				Operating	Heaviest Section	Shipping
AT 224-4N60-EV	2,933	(2)40	605,200	187,560	12,320	134,500
AT 224-4O60-EV	3,118	(2)50	650,300	188,240	12,320	135,180
AT 224-4P60-EV	3,387	(2)60	688,400	188,840	12,320	135,780
AT 224-4Q60-EV	3,595	(2)75	739,400	188,740	12,320	135,680
AT 224-4R60-EV	4,037	(2)100	808,700	189,260	12,320	136,200
AT 224-4S60-EV	4,335	(2)125	867,300	191,080	12,320	138,020
AT 224-4T60-EV	4,621	(2)150	917,800	192,200	12,320	139,140
AT 224-5N60-EV	2,958	(2)40	596,300	191,080	13,200	138,020
AT 224-5O60-EV	3,140	(2)50	640,700	191,760	13,200	138,700
AT 224-5P60-EV	3,400	(2)60	678,300	192,360	13,200	139,300
AT 224-5Q60-EV	3,600	(2)75	728,600	192,260	13,200	139,200
AT 224-5R60-EV	4,072	(2)100	796,400	192,780	13,200	139,720
AT 224-5S60-EV	4,315	(2)125	854,700	194,600	13,200	141,540
AT 224-5T60-EV	4,583	(2)150	904,500	195,720	13,200	142,660
SLSF Addition				4,200		4,200

- NOTES:**
- (1) An adequately sized bleed line must be installed in the cooling tower system to prevent buildup of impurities in the recirculated water.
 - (2) Do not use catalog drawings for certified prints. Dimensions and weights are subject to change.
 - (3) Adequate spacing must be allowed for access to the cooling tower. Refer to EVAPCO's Equipment Layout Manual.
 - (4) Nominal tonnage is based on 3 gpm per ton at 95° F entering water temperature, 85° F leaving water temperature, and 78° F wet-bulb temperature.
 - (5) Models with the "-N" suffix have up to a 3% nominal tonnage increase.
 - (6) SLSF adds 33-1/8" to unit overall height.

Structural Steel Support

Suggested I-Beam Arrangement

ONE CELL

24' x 30'

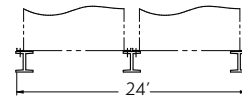
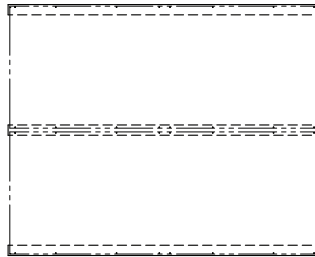

TWO CELL

48' x 30'

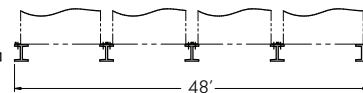
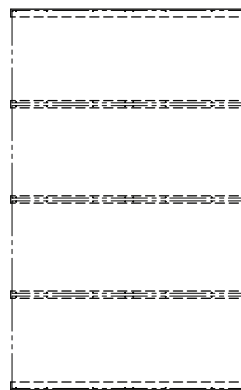

TWO CELL

24' x 60'

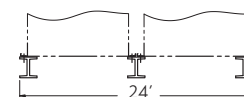
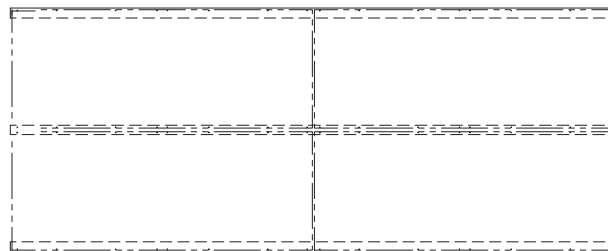

- NOTES:**
- (1) Beams should be sized in accordance with accepted structural practices. Maximum deflection of beam under unit to be 1/360 of the unit length, not to exceed 1/2" [13 mm].
 - (2) Deflection may be calculated by using 55% of the operating weight as a uniform load on each beam. See certified print for operating weight.
 - (3) Support beams and anchor hardware are to be furnished by others. Anchor hardware to be ASTM A325 5/8" [16 mm] bolt or equivalent.
 - (4) Beams must be located under the full length of the pan section.
 - (5) Support beams surface must be flush and level at top surface. Do not level the unit by placing shims between the unit mounting flange and the supporting beam.
 - (6) The factory recommended steel support configuration is shown. Consult the factory for alternate support configurations.
 - (7) Unit should be positioned on steel such that the anchoring hardware fully penetrates the beam's flange and clears the beam's web.
 - (8) For all multiple cell units, the operating weight of each cell is found by dividing total operating weight by the number of cells.
 - (9) The center beam should have a minimum width of 12" [305 mm].
 - (10) Dimensions listed as follows: English ft-in. [Metric mm].



-  World Headquarters
Research & Development Center
-  EVAPCO Manufacturing Facilities

EVAPCO, Inc. — World Headquarters & Research / Development Center

P.O. Box 1300 • Westminster, MD 21158 USA
410.756.2600 • marketing@evapco.com • evapco.com

North America

 **EVAPCO, Inc.**
World Headquarters
Westminster, MD USA
410.756.2600
marketing@evapco.com

 **EVAPCO East**
Taneytown, MD USA

 **EVAPCO East**
Key Building
Taneytown, MD USA

 **EVAPCO Midwest**
Greenup, IL USA
217.923.3431
evapcomw@evapcomw.com

 **Evapcold Manufacturing**
Greenup, IL USA

 **EVAPCO Newton**
Newton, IL USA
618.783.3433
evapcomw@evapcomw.com

 **EVAPCO West**
Madera, CA USA
559.673.2207
contact@evapcowest.com

 **EVAPCO Alcoil, Inc.**
York, PA USA
717.347.7500
info@evapco-alcoil.com

 **EVAPCO Iowa**
Lake View, IA USA

EVAPCO Iowa
Sales & Engineering
Medford, MN USA
507.446.8005
evapcomn@evapcomn.com

 **EVAPCO LMP ULC**
Laval, Quebec, Canada
450.629.9864
info@evapcolmp.ca

 **EVAPCO Select Technologies, Inc.**
Belmont, MI USA
844.785.9506
emarketing@evapcoselect.com

 **Refrigeration Vessels & Systems Corporation**
Bryan, TX USA
979.778.0095
rvs@rvscorp.com

 **Tower Components, Inc.**
Ramseur, NC USA
336.824.2102
mail@towercomponentsinc.com

 **EvapTech, Inc.**
Edwardsville, KS USA
913.322.5165
marketing@evaptech.com

EvapTech Gulf Services
Houston, TX USA
281.529.6526
angie.montes@evaptech.com

EVAPCO Dry Cooling, Inc.
Bridgewater, NJ USA
908.379.2665
info@evapcodc.com

EVAPCO Dry Cooling, Inc.
Littleton, CO USA
908.895.3236
info@evapcodc.com

Asia Pacific

EVAPCO Asia Pacific Headquarters
Baoshan Industrial Zone Shanghai, P.R. China
(86) 21.6687.7786
marketing@evapcochina.com

 **EVAPCO (Shanghai) Refrigeration Equipment Co., Ltd.**
Baoshan Industrial Zone, Shanghai, P.R. China

 **EVAPCO (Beijing) Refrigeration Equipment Co., Ltd.**
Huairou District, Beijing, P.R. China
(86) 10.6166.7238
marketing@evapcochina.com

 **EVAPCO Air Cooling Systems (Jiaxing) Company, Ltd.**
Jiaxing, Zhejiang, P.R. China
(86) 573.8311.9379
info@evapcochina.com

 **EVAPCO Australia (Pty.) Ltd.**
Riverstone, NSW, Australia
(61) 02.9627.3322
sales@evapco.com.au

EvapTech (Shanghai) Cooling Tower Co., Ltd.
Baoshan District, Shanghai, P.R. China
Tel: (86) 21.6478.0265

EvapTech Asia Pacific Sdn. Bhd.
Puchong, Selangor, Malaysia
(60) 3.8070.7255
marketing-ap@evaptech.com

Europe | Middle East | Africa

EVAPCO Europe EMENA Headquarters
Tongeren-Borgloon, Belgium
(32) 12.39.50.29
evapco.europe@evapco.be

 **EVAPCO Europe BV**
Tongeren-Borgloon, Belgium

 **EVAPCO Europe, S.r.l.**
Milan, Italy
(39) 02.939.9041
evapcoeuropa@evapco.it

 **EVAPCO Europe, S.r.l.**
Sondrio, Italy

 **EVAPCO Europe A/S**
Aabybro, Denmark
(45) 9824.4999
info@evapco.dk

EVAPCO Europe GmbH
Meerbusch, Germany
(49) 2159.69560
info@evapco.de

EVAPCO Middle East DMCC
Dubai, United Arab Emirates
(971) 56.991.6584
info@evapco.ae

 **Evap Egypt Engineering Industries Co.**
A licensed manufacturer of EVAPCO, Inc.
Nasr City, Cairo, Egypt
(20) 10.054.32.198
evapco@tiba-group.com

 **EVAPCO S.A. (Pty.) Ltd.**
A licensed manufacturer of EVAPCO, Inc.
Isando, South Africa
(27) 11.392.6630
evapco@evapco.co.za

South America

 **EVAPCO Brasil**
Equipamentos Industriais Ltda.
Sorocaba, São Paulo, Brazil
(55) 11.5681.2000
[vendas@evapco.com.br](mailto: vendas@evapco.com.br)

 **FanTR Technology Resources**
Sorocaba, São Paulo, Brazil
(55) 11.4025.1670
fantr@fantr.com