

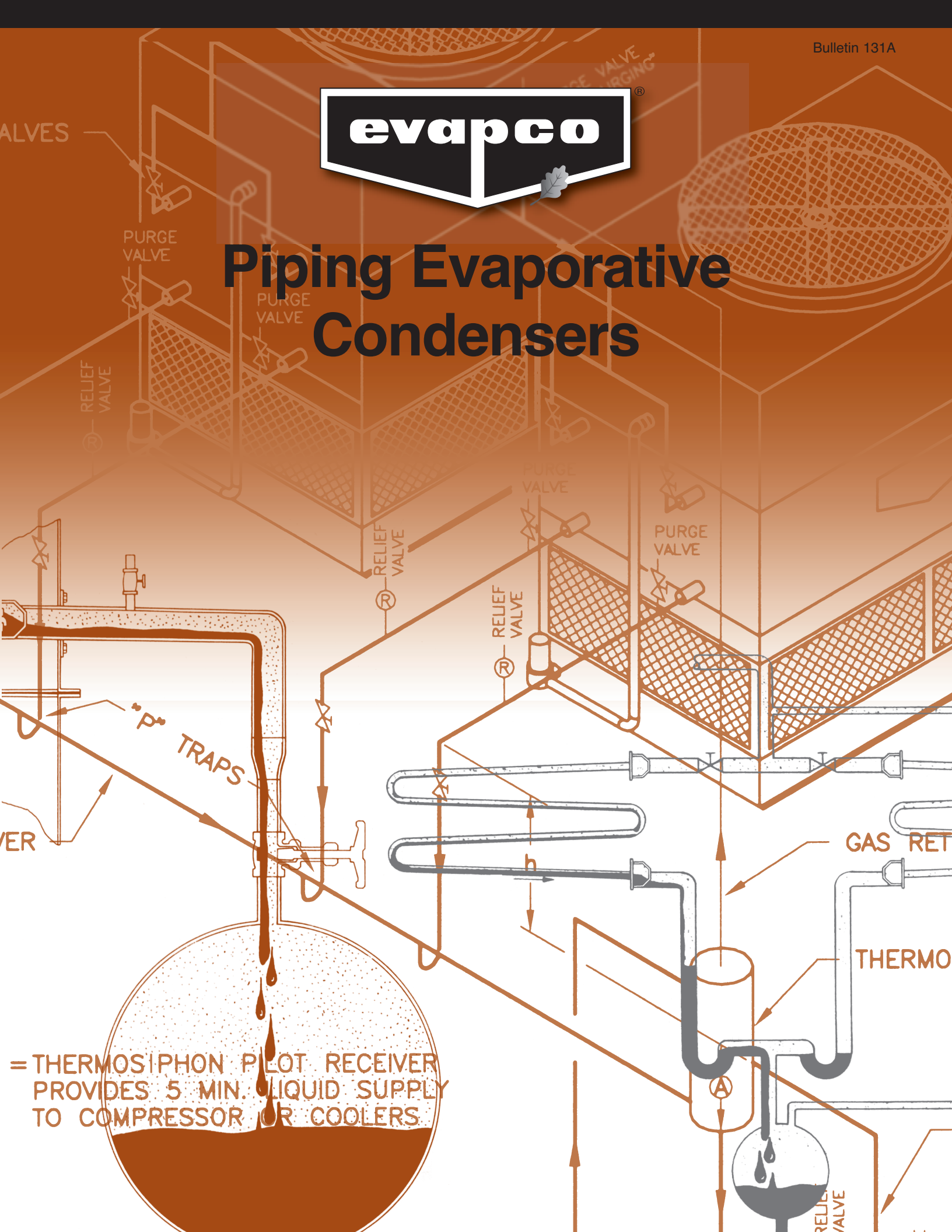

# Piping Evaporative Condensers



= THERMOSIPHON PLOT RECEIVER PROVIDES 5 MIN. LIQUID SUPPLY TO COMPRESSOR OR COOLERS

Evaporative condensers are used in refrigeration systems as an efficient means of heat rejection. Their installation and specifically the installation of the piping to and from the evaporative condenser has a direct effect on their operation and the overall energy efficiency of the refrigeration system. In this manual, we will explore the principles of piping evaporative condensers, beginning with single condensers and exploring multiple condenser installations as well as thermosiphon and sub-cooling piping systems.

## Background

Evaporative condensers came into common use for nearly all refrigeration systems because of their operating advantages over the combination of cooling towers and condensers. They, of course, have also replaced the old "once through" water cooled condensing systems which are obsolete today because of the restrictions on the unlimited use of water coupled with its high cost.

Although, shell and tube condensing systems performed the same job of condensing the hot discharge gas into a saturated liquid as evaporative condensers; a small difference in the operating characteristics, namely pressure drop, requires some modification in the refrigerant piping hookup to and from the evaporative condenser. These changes are particularly important when dealing with multiple unit installations. In order to understand why the piping hookup is important, let's first take a brief look at the basic design differences of the two types of condensers to see why there is a difference in the pressure drop characteristics.

The shell type refrigerant condensers allow the refrigerant to flow around and condense on the outside of the water tubes. (See Figure 1) The refrigerant flow is almost entirely unimpeded resulting in a very low or nearly zero pressure drop through the condenser.

TYPICAL SHELL AND TUBE WATER COOLED CONDENSER

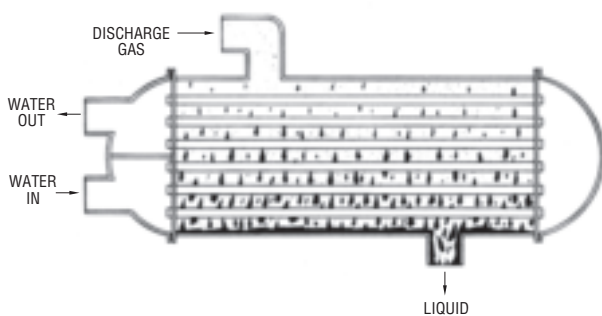

Figure 1

Contrasting, most evaporative condensers (See Figure 2) utilize some type of serpentine coil design where the hot refrigerant gas enters the top of the coil traveling back and forth through several rows as it is cooled and

TYPICAL EVAPORATIVE CONDENSER COIL

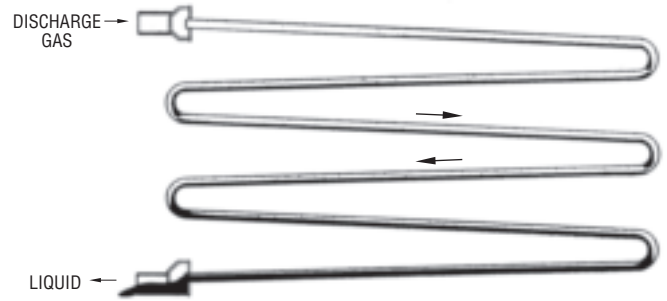

Figure 2

changed from a hot superheated gas to a saturated liquid. This longer travel path generally produces a small pressure drop which, though insignificant to the overall operation of the refrigeration system, does require proper attention be given to the condenser piping. Most of this attention needs to be focused on the liquid drain line from the outlet of the evaporative condenser to the high pressure receiver. The reasons for this will be explained in the sample pipe described later on.

## Compressor Discharge Line

The condenser can be piped into a system with either one or multiple compressors. The compressor discharge line should be sized in consideration of the length of the run from the compressor to the condenser, and the total amount of pressure drop that is to be allowed. Good practice would normally permit a pressure drop corresponding to a 1°F (.5°C) condensing penalty, per 100 equivalent feet (30m). The ASHRAE Handbook of Fundamentals uses this criteria as the basis of their capacity tables for discharge lines. For reference, Table 1 is included here to show the line carrying capacity in TR (kW) of refrigeration for the most common refrigerants in both steel pipe and copper tubing.

It is based on a line friction pressure drop of a 1°F (.5°C) change in the saturation temperature per 100 equivalent feet (30m) of pipe.

In most installations use of this table will provide a negligible difference between the actual compressor discharge pressure and that at the entrance to the condenser.

In any system, whether it is new or old, measurably higher pressure drops in the discharge line need to be taken into consideration in sizing the condenser and compressor. For example, if there was to be an 8 psi (56kPa) pressure drop in discharge line of an NH3 system, it would amount to about a 2.5°F (1.4°C) reduction in saturation temperature at the condenser. This means that either the condenser should be increased in size approximately 15 percent or it must

## Compressor Discharge Line for Steel Pipe & Copper Tubing

NOMINAL SIZE inches (mm)		R-134a		R-22		R-407C		R-410A		R-507		R-717
STEEL	COPPER	STEEL	COPPER	STEEL	COPPER	STEEL	COPPER	STEEL	COPPER	STEEL	COPPER	STEEL
1 (25)	1-1/8 (29/26)	4 (17)	6 (26)	7 (30)	9 (37)	6 (25)	9 (38)	8 (36)	13 (57)	5 (21)	8 (34)	15 (64)
1-1/4 (32)	1-3/8 (35/32)	10 (44)	10 (45)	14 (62)	15 (64)	12 (52)	15 (66)	18 (76)	23 (99)	11 (46)	14 (59)	39 (168)
1-1/2 (40)	1-5/8 (41/38)	15 (65)	16 (71)	22 (93)	23 (101)	18 (79)	24 (105)	27 (116)	36 (156)	16 (69)	22 (93)	59 (252)
2 (50)	2-1/8 (54/50)	29 (126)	34 (146)	41 (178)	49 (209)	43 (184)	50 (217)	63 (270)	75 (321)	37 (161)	44 (191)	113 (487)
2-1/2 (64)	2-5/8 (67/63)	47 (201)	60 (258)	66 (284)	85 (368)	68 (294)	89 (382)	100 (430)	131 (565)	60 (256)	78 (337)	180 (776)
3 (80)	3-1/8 (79/75)	83 (355)	96 (411)	116 (501)	136 (587)	120 (519)	141 (608)	176 (760)	209 (900)	105 (453)	124 (536)	318 (1370)
4 (100)	4-1/8 (105/99)	168 (723)	200 (862)	237 (1021)	284 (1225)	245 (1056)	295 (1271)	359 (1545)	436 (1878)	214 (921)	260 (1119)	648 (2792)

### NOTES:

- CAPACITIES SHOWN ARE TONS (kW)
- STEEL PIPE 1-1/2 INCH (38mm) AND SMALLER SCH. 80, 2 INCH (50mm) AND LARGER SCH. 40.
- CAPACITIES BASED ON THE FOLLOWING CONDITIONS:  
R-22, R-134a, R-407C, R-410A, AND R-507: 40°F (4.4°C) SUCTION, 105°F (40.6°C) CONDENSING  
R-717: 20°F (-6.7°C) SUCTION, 96.3°F (35.7°C) CONDENSING.
- CAPACITIES BASED ON LINE FRICTION PRESSURE DROP PER 100 FEET (30m) OF EQUIVALENT PIPE LENGTH WHICH CORRESPONDS TO A 1°F (.5°C) CHANGE IN SATURATION TEMPERATURE. THIS LINE FRICTION PRESSURE DROP PER 100 FEET BY REFRIGERANT IS  
R-22: 3.05 PSI (21.0 KPa)      R-407C: 3.50 PSI (24.1 KPa)      R-507: 3.65 PSI (25.2 KPa)  
R-134a: 2.20 PSI (15.2 KPa)      R-410A: 4.75 PSI (32.8 KPa)      R-717: 3.10 PSI (21.4 KPa)

Table 1

be accepted that the compressor discharge pressure will be 8 psi (55kPa) higher than design.

Special consideration should be given to discharge line sizing when centrifugal compressors are being used. These machines have more critical head characteristics that may necessitate larger line sizes.

### Liquid Drain Line—Single Condensers

Now let's consider the recommended piping for a single condenser illustrated in Figure 3.

This figure shows a single coil evaporative condenser properly piped into a system with a top inlet high pressure receiver. The compressor discharge line contains a purge valve at the high point and a service valve. The liquid drain line is properly sloped and a relief valve from the condenser. It contains a purge valve in the horizontal portion, and a service valve has been installed in the vertical portion. The receiver is fitted with another purge connection and relief valve.

The liquid drain line from the condenser to the receiver as was noted earlier, must receive the most careful attention. It is fundamental that this line be designed to allow the liquid to flow freely, by gravity, to the receiver. The sizing of the line depends upon whether it runs directly from the condenser to the top of the receiver or whether it is trapped if it entered the bottom of the receiver.

In an untrapped situation as shown, the liquid drain line must be sized so that this low velocity will insure there is sewer drainage in the line. (Figure 4) That is, there is space above the liquid flow for free vapor movement in either direction.

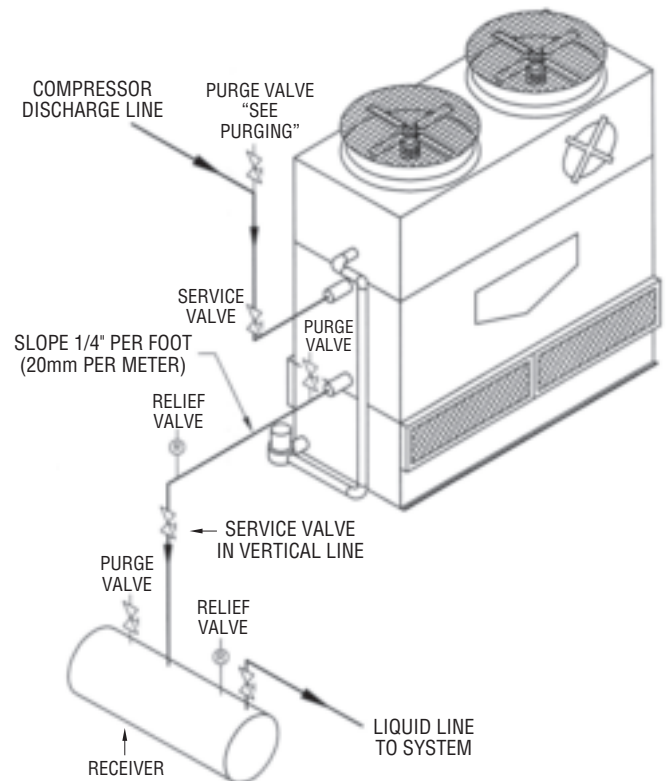

Figure 3

This allows the pressure in the receiver to be equalized with the pressure at the coil outlet and thus will allow free liquid flow from the condenser outlet to the receiver. The liquid drain line should also be pitched at least 1/4 inch per foot (20mm per meter) toward the receiver to facilitate this flow.

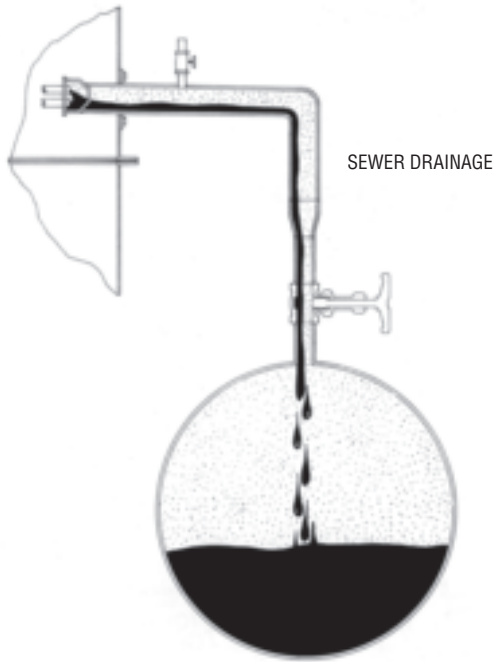

Figure 4

When the liquid drain line is trapped, as in Figure 5, a free flow of vapor and hence pressure equalization between the receiver and coil outlet cannot occur through the liquid line. In this case a separate line must run from the top of the receiver to the outlet of the coil to serve as an equalizer.

Now since the liquid drain line is handling only liquid it can be reduced in size somewhat. In this case, the line size should be based on the values listed in table 2.

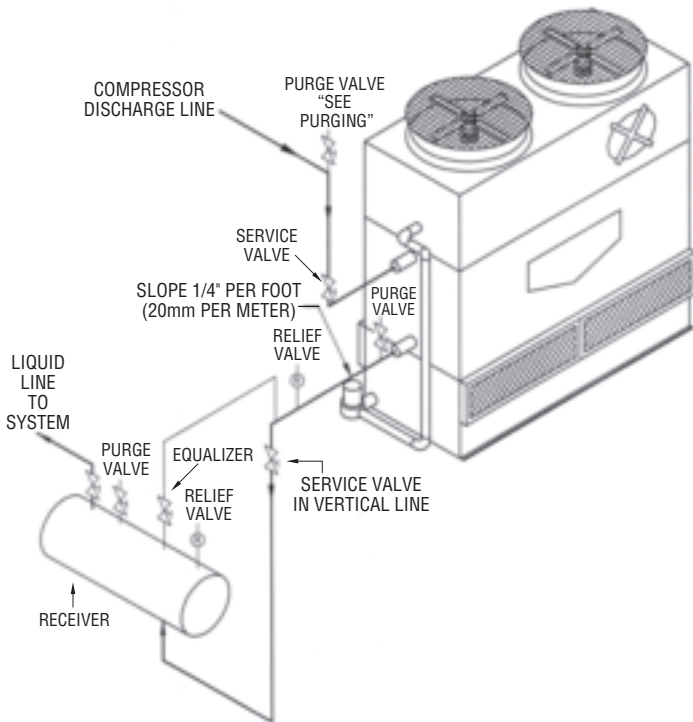

Figure 5

Evaporative condensers are often provided with oversized outlet connections. In this case the drain line can be reduced from the size furnished by the factory and still meet the criteria. It is permissible to reduce the line as shown in Figure 6, but it is recommended that it be done in the vertical portion of the line. If using this method, then the installation of shut off or service valves is preferred in the vertical portion of the line, and at least a foot below the horizontal portion.

**RECOMMENDED METHOD OF REDUCING LINE SIZE IN VERTICAL PIPE**

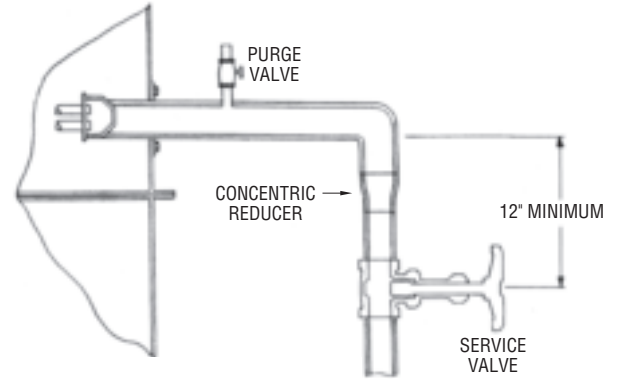

Figure 6

An often used but not preferred alternate method (Figure 7) of reducing the condenser outlet size may also provide satisfactory operation. After the purge valve, an eccentric reducer may be installed in the horizontal portion of the line. Also, an angle type shut-off valve may be installed provided the seat design allows complete drainage from the bottom of the horizontal pipe.

**ALTERNATE METHOD OF REDUCING LINE SIZE IN HORIZONTAL PIPE**

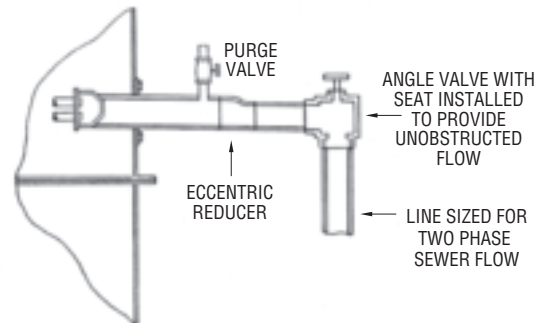
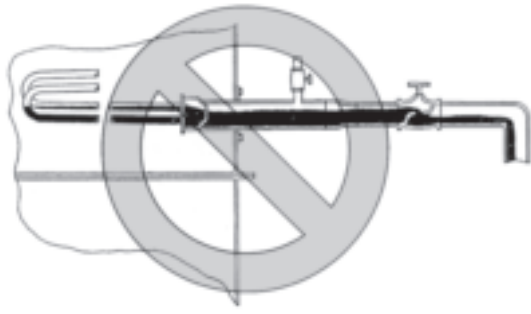

Figure 7

In this arrangement the drain line should always be sized for two phase sewer flow regardless of the hookup. It is recommended, for best results, that the velocity be kept as low as possible, particularly if an angle valve is installed.



- NEVER USE:  
 1) CONCENTRIC REDUCERS IN HORIZONTAL DRAIN LINE  
 2) VALVES IN HORIZONTAL DRAIN LINE

**Figure 8**

There are a lot of condensers operating with the drain lines reduced in the horizontal portion by concentric reducers and with horizontal valves as well. (See Figure 8)

Such an arrangement should never be considered. These units are working with the liquid backed up in the bottom row or rows of the coil thereby suffering capacity loss and other potential problems.

For optimum capacity and lowest head pressures

carefully follow the previous recommendation using the line sizing criteria as absolute maximums at full load conditions. Table 2 is included for reference, listing the capacity in Tons (kW) for condenser drain lines for the most common refrigerants for both two phase flow and trapped liquid flow for steel pipe and copper tubing. Both purge connections and equalizer line sizing will be discussed in more detail after the piping hookup for multiple condensers are reviewed.

**Liquid Drain Lines–Multiple Condensers**

Multiple condensers operating in parallel must be piped correctly to realize maximum capacity and stable operation under all load and ambient conditions. Some installations that are improperly connected will work fine under normal loads when all units are in operation. However, under either part load or full load conditions at lower ambient temperatures when units begin cycling off, the system becomes unstable. There may be large fluctuations in receiver liquid levels or some of the condensers suddenly seem to become short of capacity. All of these symptoms can be attributed to piping deficiencies.

**Condenser Liquid Drain Line for Steel Pipe & Copper Tubing  
Two Phase Sewer Flow**

NOMINAL SIZE Inches (mm)	R-134a		R-22		R-407C		R-410A		R-507		R-717
	STEEL	COPPER	STEEL	COPPER	STEEL	COPPER	STEEL	COPPER	STEEL	COPPER	STEEL
1 (25)	7 (29)	8 (33)	7 (29)	8 (34)	6 (27)	7 (31)	6 (24)	6 (28)	4 (17)	5 (20)	24 (103)
1-1/4 (32)	14 (60)	14 (59)	14 (61)	14 (60)	13 (57)	13 (55)	12 (51)	12 (50)	8 (36)	8 (36)	50 (215)
1-1/2 (40)	22 (93)	22 (93)	22 (94)	22 (95)	20 (87)	20 (88)	18 (78)	18 (79)	13 (56)	13 (56)	77 (332)
2 (50)	39 (168)	36 (155)	40 (172)	37 (158)	37 (159)	34 (146)	33 (142)	30 (131)	24 (102)	22 (94)	140 (603)
2-1/2 (65)	61 (265)	61 (264)	63 (270)	62 (269)	58 (249)	58 (249)	52 (223)	52 (222)	37 (160)	37 (160)	220 (948)
3 (80)	104 (450)	97 (417)	107 (460)	98 (424)	99 (425)	91 (392)	88 (380)	81 (350)	63 (273)	58 (252)	375 (1616)
4 (100)	178 (767)	167 (718)	181 (781)	170 (734)	167 (721)	157 (678)	149 (644)	141 (606)	108 (463)	101 (436)	740 (3188)

**Trapped Liquid Line**

NOMINAL SIZE Inches (mm)	R-134a		R-22		R-407C		R-410A		R-507		R-717
	STEEL	COPPER	STEEL	COPPER	STEEL	COPPER	STEEL	COPPER	STEEL	COPPER	STEEL
1 (25)	10 (43)	12 (50)	10 (44)	12 (51)	9 (41)	11 (47)	8 (36)	10 (42)	6 (26)	7 (30)	36 (155)
1-1/4 (32)	21 (90)	21 (89)	21 (92)	21 (90)	20 (85)	19 (83)	18 (76)	17 (75)	13 (55)	12 (54)	75 (323)
1-1/2 (40)	32 (139)	33 (140)	33 (142)	33 (143)	30 (131)	31 (131)	27 (117)	27 (118)	20 (84)	20 (85)	116 (498)
2 (50)	59 (253)	54 (233)	60 (258)	55 (237)	55 (238)	51 (220)	49 (231)	46 (196)	35 (153)	33 (141)	210 (905)
2-1/2 (65)	92 (397)	92 (395)	94 (405)	94 (404)	87 (374)	87 (374)	78 (223)	77 (333)	56 (240)	56 (240)	330 (1422)
3 (80)	157 (975)	145 (625)	160 (690)	148 (636)	148 (637)	136 (587)	132 (570)	122 (525)	95 (409)	88 (378)	563 (2423)
4 (100)	267 (1151)	250 (1077)	272 (1171)	256 (1102)	251 (1082)	236 (1018)	224 (966)	211 (909)	161 (695)	152 (654)	1110 (4782)

**NOTES:**

- CAPACITIES LISTED IN TONS (kW).
- STEEL PIPE 1-1/2 INCH (38mm) AND SMALLER SCH. 80, 2 INCH (50mm) AND LARGER SCH. 40.

**Table 2**

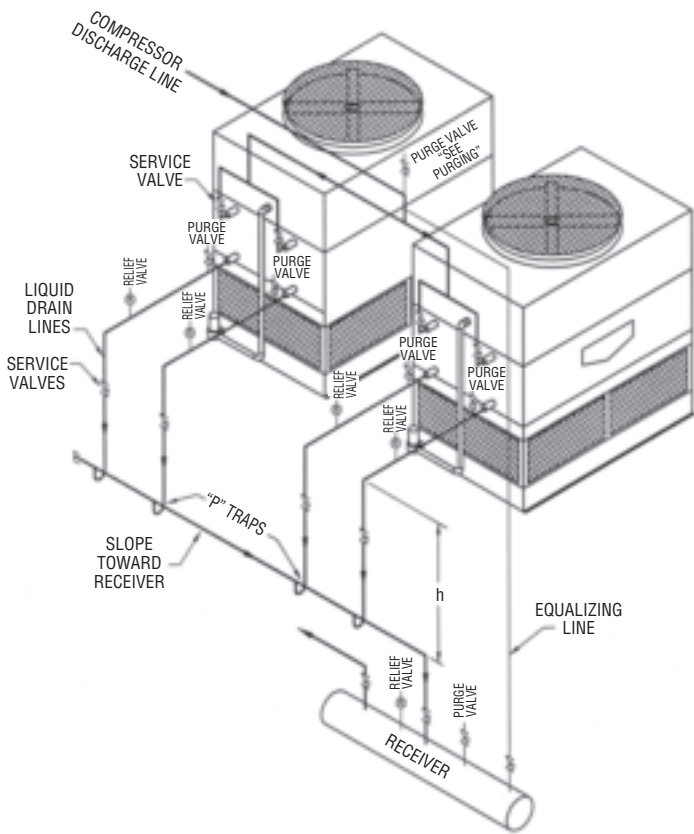

Figure 9

Figure 9 illustrates two large condensers piped in parallel to a single high pressure receiver. Note that the compressor discharge line should be piped as symetrically as possible. The earlier comments in regard to the sizing of these lines also apply to multiple condenser installations.

Again, the most important aspect of multiple unit hookups is the condenser to receiver liquid drain line piping. The key is to **trap it!** The drain line from each coil outlet must have a trap in the vertical portion of the line. This can be accomplished with a small "P" trap as illustrated in Figure 9 or by using a bottom inlet receiver as illustrated in Figure 10.

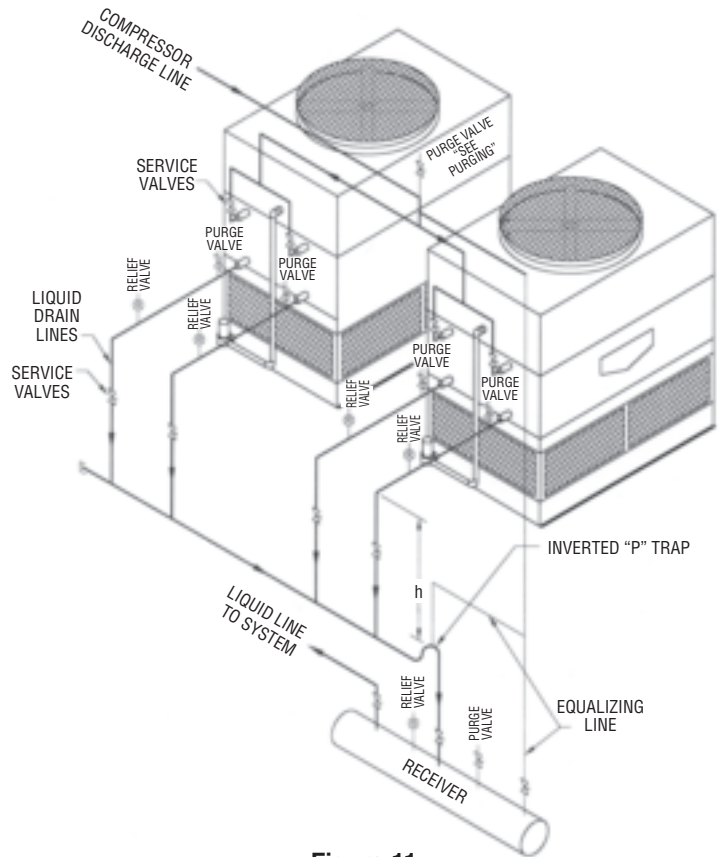

Figure 11

An alternative method for trapping liquid outlets on multiple condenser installations is illustrated in Figure 11. All the outlets are piped together into one liquid header. A single inverted "P" trap is used to create a liquid seal on the entire header. In order to prevent the refrigerant from siphoning from the header, the equalizer line must connect into the top of the inverted trap as a vacuum breaker as shown in close-up in Figure 12.

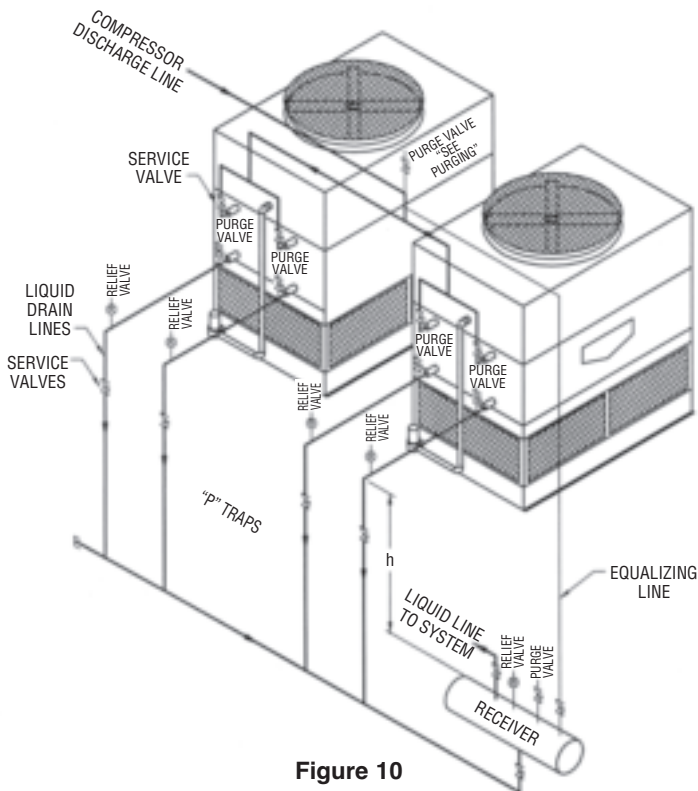

Figure 10

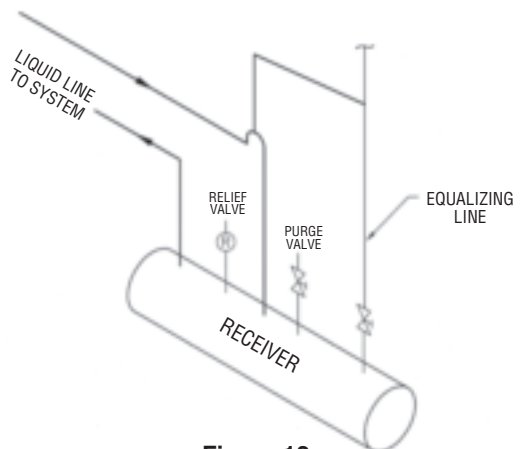

Figure 12

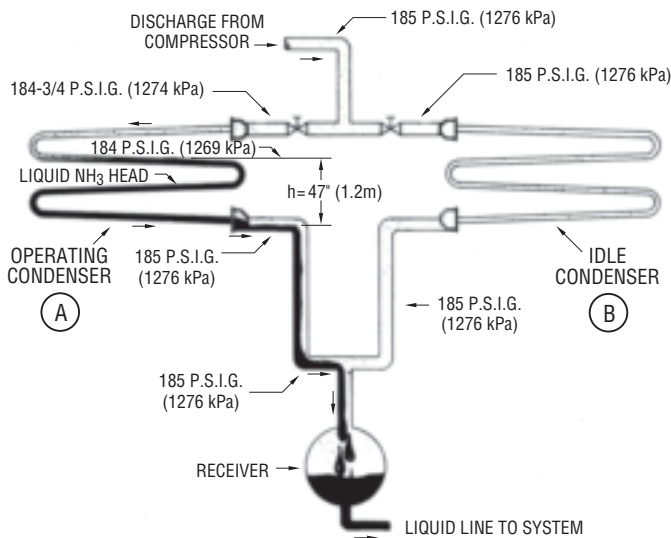

Figure 13

It is essential to trap these lines in order to build a vertical liquid column in the drop legs to offset the potential variations in pressures between coil outlets. Without these trapped liquid legs the liquid refrigerant will bottle up in the coils with the highest pressure drop (or lowest outlet pressure) subsequently reducing available capacity and producing unstable operation.

This important concept in piping multiple evaporative condensers is best understood by referring to a couple of simplified examples.

Figure 13 illustrates the *wrong way*. It shows two NH<sub>3</sub> condensers A and B piped in parallel in which the liquid drain lines are not trapped, but can freely drain to the receiver. In this example Condenser A is in operation and Condenser B is idle. The idle condenser has no flow through it so there is no pressure drop, and the discharge line pressure of 185 P.S.I.G. (1276 kPa) equalizes to the receiver. The operating condenser under full load has a total pressure drop of 1 P.S.I. (7 kPa). It consists of 1/4 P.S.I. (2 kPa) across the inlet service valve and 3/4 P.S.I. (5 kPa) through the coil. But this situation creates an impossible condition to have a flow of refrigerant. The liquid cannot flow from the low pressure of 184 P.S.I.G. (1269 kPa) into the higher pressure of 185 P.S.I.G. (1276 kPa). Therefore, what happens is a liquid head builds up or "bottles" in the operating condenser until the pressure difference or loss is offset. In this case the pressure difference is 185 P.S.I.G. (1276 kPa) minus 184 P.S.I.G. (1269 kPa) or 1 P.S.I. (7 kPa). One pound (7 kPa) is equivalent to a liquid head of 47 inches (1.2m) which will build up in the operating condenser in order to establish the flow of refrigerant.

This amount of head dimensioned as "h" in the drawing would nearly fill an average evaporative

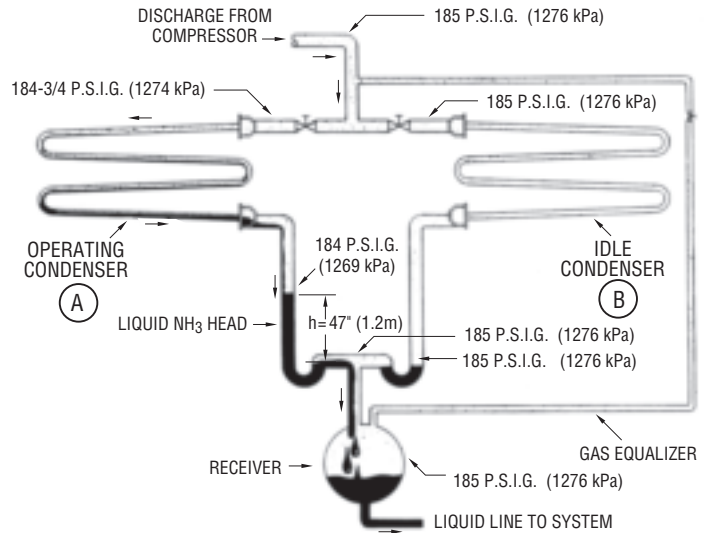

Figure 14

condenser coil with liquid. Such a liquid head greatly reduces the available condensing surface so that in addition to possibly starving the system for refrigerant, the head pressure would elevate dramatically. The liquid drain line would probably feel cool, because the liquid filled condenser would be acting like a subcooler.

In Figure 14 the two condensers have been repiped to include a liquid drop leg that has been trapped at the bottom of a horizontal liquid header draining to the receiver. An equalizer line has also been added from the receiver to the hot gas discharge line. This is necessary to maintain a stable pressure in the receiver which will insure free drainage from the condensers.

Under the identical operating conditions as before, a liquid head must again be developed in order to produce flow. There is still a one pound pressure drop in the operating condenser producing a lower pressure (184 P.S.I.G./1269 kPa) at its outlet as compared to the idle condenser (185 P.S.I.G./1276 kPa) and the receiver (185 P.S.I.G./1276 kPa). The trap creates a liquid seal so that now the one pound liquid head ("h") of 47 inches (1.2m) builds up in the vertical drop leg not in the condenser coil.

There must be enough height above the trap in the vertical liquid leg to accommodate a liquid head equal to the maximum pressure drop that will be encountered in the condenser. The example illustrated the extreme case of one unit on and one off, however, the same phenomenon happens to a lesser degree between two different condensers of differing pressure drops when both are in full operation. There, also, can be substantial differences in pressure drop between two different brands of the same size condenser or even different models of the same manufacturer.

Evapco's standard recommendation for the minimum height of the vertical leg is 5 feet (1.5m) for ammonia and 12 feet (3.7m) for halocarbon refrigerants. This is the vertical dimension "h" indicated in Figure 9. These are the minimum drop leg heights for satisfactory operation within reasonable ranges around the "nominal" design conditions and are primarily based upon the maximum condensing pressure drop of the coil. If service valves are included at the coil inlets and/or outlets, the pressure drops imposed by these valves must be accounted for by increasing the above recommended minimum dropleg heights by an amount equal to the valve pressure drop in feet of liquid refrigerant.

Under low ambient conditions the condenser capacity will be significantly increased. This increase in capacity sometimes will allow one or more condensers to be shut down, with the remaining condensers able to handle the full compressor load. As a result of this increased flow rate of refrigerant through the unit, the pressure drop across the coil and associated piping will be much greater than the pressure drop at "nominal design" conditions. Also at low ambient, the condensing pressure is sometimes significantly reduced to save operating energy. The resultant lower gas density has the effect of increasing the pressure drop. In order for the condenser to operate at maximum efficiency, at the lowest system energy at these low ambient conditions, taller drop legs are required.

**Whenever possible the drop legs should be designed approximately 50% taller than the minimum recommended height.**

(Note that other manufacturers may recommend different heights for these drop legs depending on their condenser design.)

Referring again to Figure 9 the vertical portion of the drop legs should be sized as a liquid line. The horizontal header draining to the receiver should be sloped 1/4" per foot (20mm/meter) towards the receiver and be sized for a sewer flow. Note that the horizontal header itself is not trapped. The equalizing line runs from the receiver to a centrally located position in the discharge line feeding the condensers. Under no circumstances should this line tie into the outlets of multiple condensers as this has the same effect as eliminating the traps. It will cause bottling in the condensers with the lowest outlet pressures.

In a multiple condenser system using a bottom inlet receiver as shown in Figure 10 the minimum height "h" is calculated from the highest level of liquid in the receiver. Both the vertical liquid legs and the now trapped horizontal header may be sized as a trapped liquid line. Often an evaporative condenser will be placed in parallel with a shell and tube condenser as illustrated in Figure 15.

The same piping considerations apply in this case as well. The pressure drop in a shell type water cooled

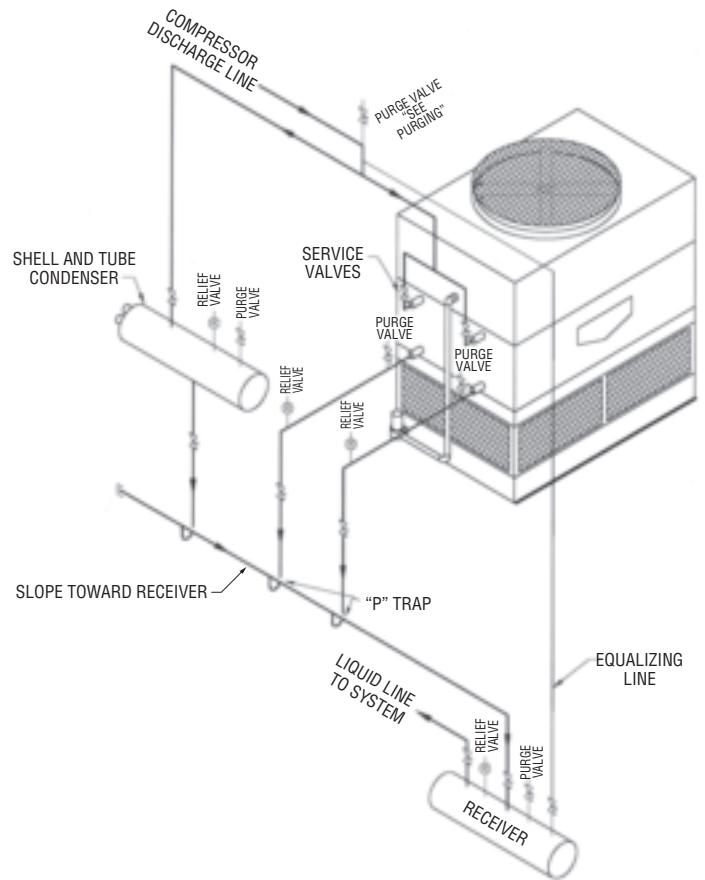

Figure 15

condenser, however, is generally very small so that the height of its vertical drop leg can be minimal or only about 12 inches (0.3m). Basically, this type of condenser only needs to be located above the receiver high enough to obtain a flow of liquid.

### Equalizers & Receivers

In all of the typical piping hookups that have been discussed there has been a receiver and a means to equalize the pressure in it. The receiver provides a reservoir for the liquid refrigerant in order to handle the fluctuations in the refrigerant charge needed in either the high or low side of the system as the loads and operating conditions change. It also allows complete drainage of the condenser so there is no loss of effective condensing surface from liquid being stored in the coil.

Depending upon the ambient temperature around the receiver there may be either gas condensing or liquid flashing inside of it. An equalizer line is required to relieve these potential uneven pressure conditions. If for example the condensing temperature is 90°F (32.2°C) and the receiver is in an engine room that is 100°F (37.8°C) there will be liquid flashing inside and a potentially high pressure. Therefore, in order to permit the liquid to freely drain from the condenser the receiver must be equalized in pressure with the hot gas discharge line.



In the case of a single coil unit as shown in Figure 3 and enlarged in Figure 4, where the liquid drain line is not trapped, the equalization can occur in the drain line itself provided it is properly sized for sewer drainage. If the liquid drain line to a single coil unit is trapped, as in Figure 5, then the equalizer line can be connected to the drain line right at the coil outlet or to the discharge line just ahead of the condenser inlet. If connected to the discharge line then the height of the vertical liquid leg must be enough to offset the coil pressure drop in the condenser as explained under multiple condensers.

For multiple condenser installations illustrated in Figures 9-11, and 14-16, the equalizer line always runs from the receiver to a point on the discharge line positioned as symmetrically to the condenser inlets as possible. **Never equalize to the outlets of the condenser in multiple unit installations since this destroys the effect of the trapped liquid legs.**

Sizing equalizer lines is done more often by experience rather than calculation. The system designer must take into account the surface area of the receiver, distance from the receiver to the condenser, height of the droplegs, temperature difference between ambient and condensing temperature and any other equipment in the system that might create flash gas into sizing the equalizer

line. Table 3 provides a guide to selecting suitable size equalizers that have been found to be satisfactory for most typical ammonia refrigeration systems.

For other applications involving halocarbon refrigerants, the system design engineer must apply the principles described above to identify the proper equalizer line size for their specific installation.

**Guide for Sizing Equalizer Lines for R-717**

PIPE SIZE Inches (mm)	MAXIMUM SYSTEM CAPACITY Tons (kW)
3/4" (20)	50 (215)
1" (25)	86 (370)
1-1/4" (32)	160 (689)
1-1/2" (38)	225 (969)
2" (50)	450 (1937)
2-1/2" (65)	650 (2800)
3" (80)	1000 (4300)
4" (100)	1800 (7750)

**Table 3**

**Thermosiphon Oil Cooling**

Thermosiphon oil cooling is a very popular means of oil cooling. Liquid refrigerant from the evaporative condenser drains into a pilot receiver. The pilot

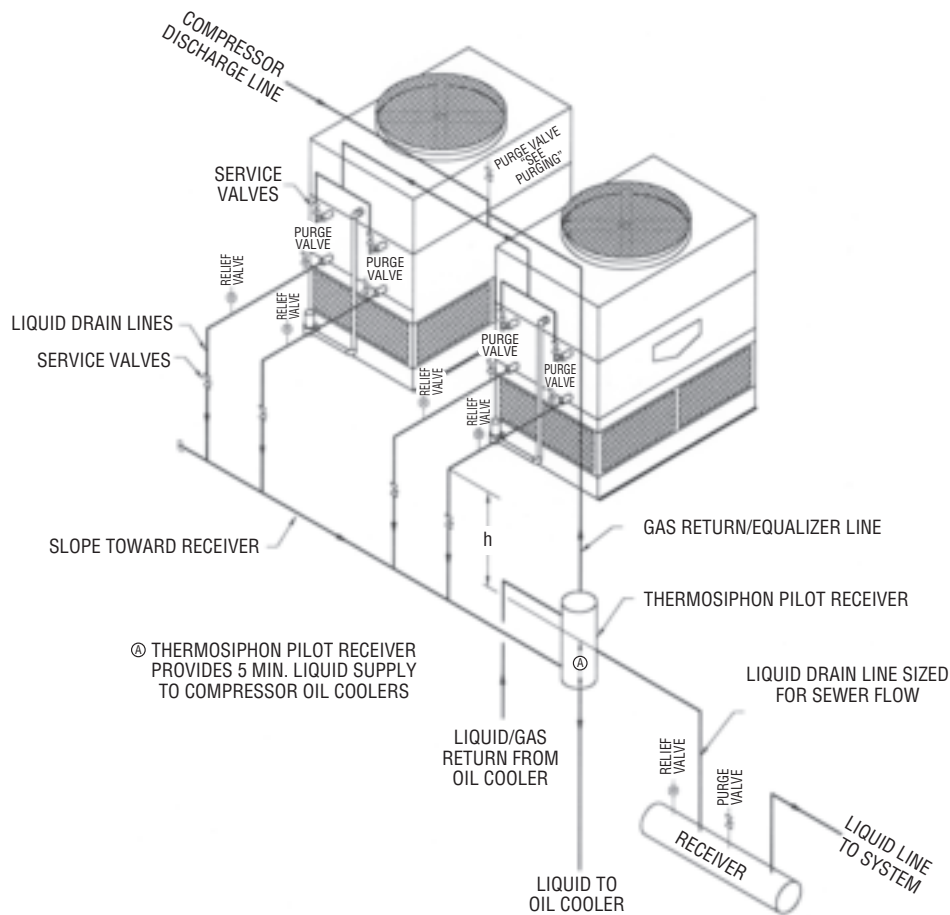

**Figure 16**

receiver then feeds liquid refrigerant to the oil coolers by gravity. In the oil coolers a part of the liquid is converted to vapor in the process of cooling the oil. The liquid-gas refrigerant mixture is returned to the pilot receiver and the vapor generated is separated in the receiver and returned to the condenser through the gas return/equalizer line. The rest of the liquid refrigerant flows from the pilot receiver to the main receiver and then on to the rest of the system.

The pilot receiver serves as a reservoir for refrigerant whose primary function is to feed the oil coolers. Liquid for oil cooling is given priority over system liquid supply. Therefore, the liquid outlet to the oil coolers is at the bottom of the receiver and is sized using the liquid line criteria described above. Refrigerant is allowed to overflow to the main receiver and the connecting line is sized based on sewer flow. The dropleg height is measured from the liquid drain line to the main receiver to the coil connection elevation and shown by the 'h' dimension in Figure 16.

### Sub-Cooling

For applications involving long runs of liquid lines or for application involving thermo-expansion fed evaporators, sub-cooling coils installed in the evaporative condenser may be employed to cool the liquid refrigerant. Sub-cooling refrigerant will prevent flash gas from forming in the liquid line which affect the operation of thermostatic expansion valves.

Figure 17 shows the proper way to pipe to a sub-

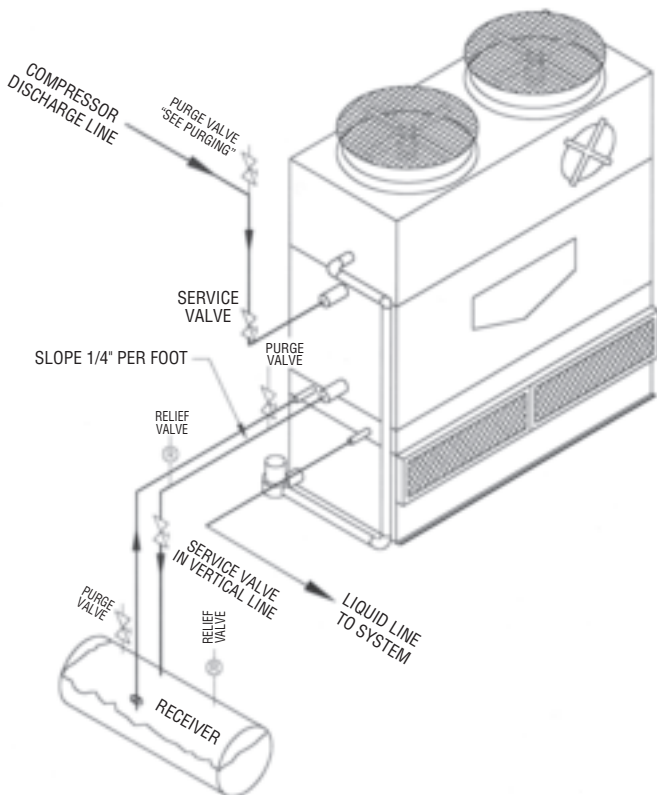

Figure 17

cooling coil. Liquid refrigerant is allowed to drain into the receiver and then returned to the condenser and into the sub-cooling coil before traveling on to the evaporator.

### Purging

All of the sample piping layouts have shown one or more purge connections. The design and proper use of these purge outlets to remove non-condensables from the system are important in obtaining the lowest operating costs for the condenser and refrigeration system. Air and other non-condensable gases are present and collect in refrigeration systems from a number of sources:

- 1) Insufficient evacuation prior to initial charging or after the system has been opened for repairs.
- 2) Leaks in low side of system if operating pressures are below atmosphere.
- 3) Addition of poor quality refrigerant containing noncondensables.
- 4) Chemical breakdown of oil and/or refrigerant.

The presence of non-condensables has the effect of raising the design condensing pressure which, of course, increases the system operating power requirements. As these contaminants build-up the condensing pressure will continue to rise. The percentage of non-condensables versus the amount of increased head pressure is not an exact relationship, but small amounts can produce significant increases in power costs.

During system operation the non-condensable gases will be swept through the condenser and, therefore, become most highly concentrated at the condenser outlets and in the receiver. When the system is shut down they will tend to collect at the high point of the system which is generally in the discharge line close to the condenser inlets. Purge connections of 1/2" to 3/4" (15 to 20mm) in size should be located at each of these locations: the receiver, the outlet of each coil connection and the high point of the system. Each connection must be separately valved, but may then be cross connected into a single purge line which may or may not be connected to an automatic purger.

Normally accepted safety procedures and caution must be followed when manual purging is practiced. Purging during operation is the most common procedure and is generally considered the most effective. It is accomplished by opening the purge valves at the coil outlets one at a time and also at the receiver. If the purge connections at the coil outlets are crossconnected, opening more than one valve at a time will have the effect of interconnecting the condenser outlets. This will negate the liquid drop legs and possibly cause liquid to back up into the

condenser coils. Purging from the high point in the system is only effective when the system has been shut down.

Note: Purging some refrigerants to atmosphere is regulated by federal and local jurisdictions.

### **Miscellaneous Piping Considerations**

- 1) Plan ahead for the possibility of future expansions. This is particularly important in line sizing, determining elevations above the receiver, and providing adequate space to obtain proper airflow.
- 2) Make sure the piping is properly designed to allow some flexibility for expansion, contraction and vibration.
- 3) Any refrigeration valves in a horizontal pipe run should be installed with the valve stem also in a horizontal position.
- 4) In NH<sub>3</sub> systems with multiple parallel compressors always crossconnect the individual discharge lines and run a common discharge line to the condensers. In multiple compressor freon systems either isolate each compressor circuit or provide an appropriate oil return system for the compressors.
- 5) Include safety relief valves at the condenser when service valves are installed at both the intake and outlets. Freak incidents have occurred where the condenser coils have been filled with liquid refrigerant and valved off. Then a change in ambient temperature generated hydraulic forces sufficient to rupture the coils.
- 6) Angle valves are commonly used in refrigeration piping and are acceptable. They must be properly oriented with full size orifices and provide the same flow resistance as a normal elbow.
- 7) Piping should be installed in accordance with applicable codes and good engineering practice. All piping should be anchored by properly designed hangers and supports with allowance made for possible expansion and contraction. No external loads should be placed upon the coil connection nor should any of the pipe supports be anchored to the unit framework.

### **Layout**

Frequently, piping considerations influence the physical placement of evaporative condensers. In making these decisions, care should be exercised to insure that proper airflow in and out of the condenser will be provided. It is just as important to the operation of the condenser as proper piping. Sometimes with add-on installations the airflow provisions are so poor that the new condenser adds little to the capacity of the system.

Layout is a separate subject in itself, which will not be dealt within this manual. Refer to EVAPCO Bulletin entitled "Equipment Layout" for additional information on layout or consult the Sales Representative nearest you.



EVAPCO products are manufactured worldwide.

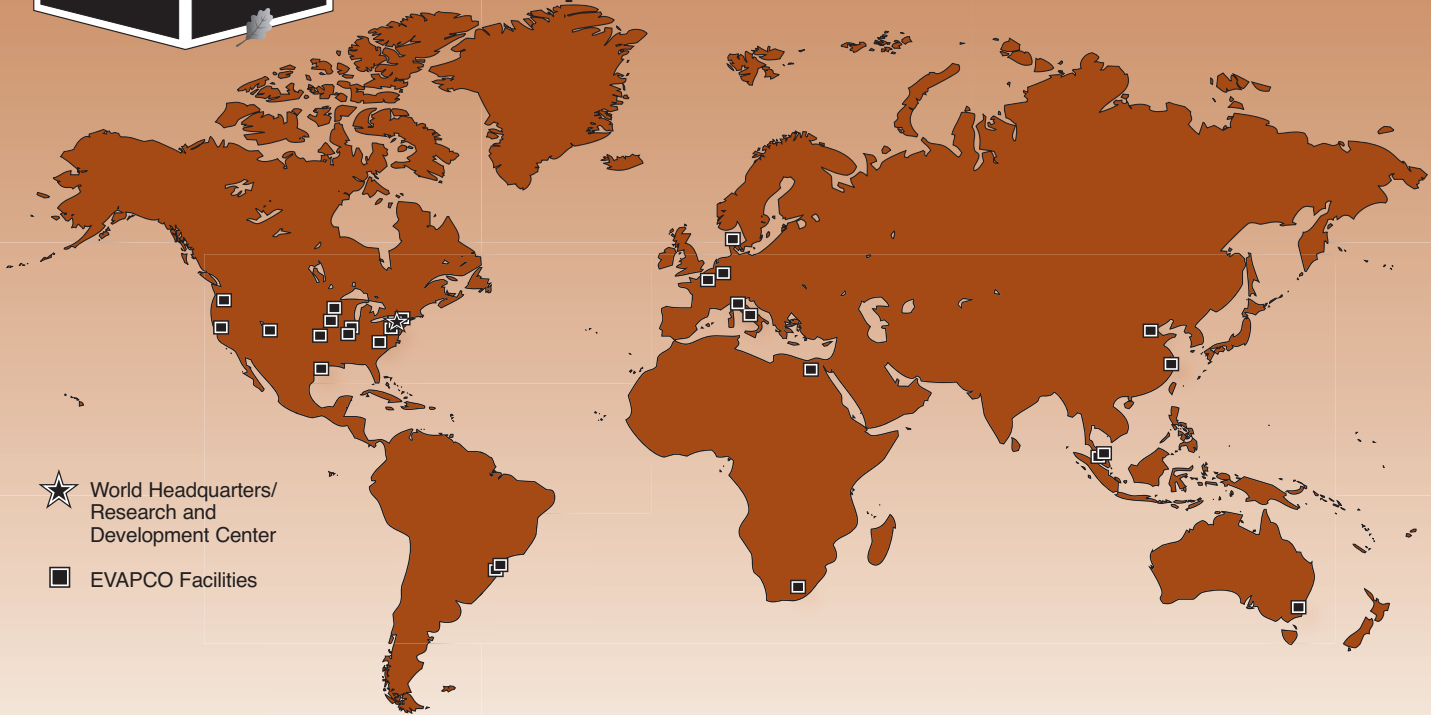

- ★ World Headquarters/ Research and Development Center
- EVAPCO Facilities

**EVAPCO, Inc. — World Headquarters & Research/Development Center**

P.O. Box 1300 • Westminster, MD 21158 USA  
410-756-2600 p • marketing@evapco.com • evapco.com

**North America**

**EVAPCO, Inc.**  
**World Headquarters**  
 P.O. Box 1300  
 Westminster, MD 21158 USA  
 410-756-2600 p | 410-756-6450 f  
 marketing@evapco.com

**EVAPCO East**  
 5151 Allendale Lane  
 Taneytown, MD 21787 USA  
 410-756-2600 p | 410-756-6450 f  
 marketing@evapco.com

**EVAPCO East**  
 Key Building  
 Taneytown, MD USA  
 410-756-2600 p  
 marketing@evapco.com

**EVAPCO Midwest**  
 Greenup, IL USA  
 217-923-3431 p  
 evapcomw@evapcomw.com

**EVAPCO West**  
 Madera, CA USA  
 559-673-2207 p  
 contact@evapcowest.com

**EVAPCO Iowa**  
 Lake View, IA USA  
 712-657-3223 p

**EVAPCO Iowa**  
 Sales & Engineering  
 Medford, MN USA  
 507-446-8005 p  
 evapcomn@evapcomn.com

**EVAPCO Newton**  
 Newton, IL USA  
 618-783-3433 p  
 evapcomw@evapcomw.com

**EVAPCOLD**  
 Greenup, IL USA  
 217-923-3431 p  
 evapcomw@evapcomw.com

**EVAPCO-BLCT Dry Cooling, Inc.**  
 1011 US Highway 22 West  
 Bridgewater, NJ 08807 USA  
 Phone: 1-908-379-2665  
 E-mail: info@evapco-blct.com

**EVAPCO-BLCT Dry Cooling, Inc.**  
 7991 Shaffer Parkway  
 Littleton, CO 80127 USA  
 Phone: 1-908-379-2665  
 E-mail: info@evapco-blct.com  
 Spare Parts Phone: 908-895-3236  
 Spare Parts e-mail: spares@evapco-blct.com

**EVAPCO Power México S. de R.L. de C.V.**  
 Calle Iglesia No. 2, Torre E  
 Tizapan San Ángel, Del. Álvaro Obregón  
 Ciudad de México, D.F. México 01090  
 Phone: +52 (55) 8421-9260  
 e-mail: info@evapco-blct.com

**Refrigeration Valves & Systems Corporation**  
 A wholly owned subsidiary of EVAPCO, Inc.  
 Bryan, TX USA  
 979-778-0095 p  
 rvs@rvscorp.com

**EvapTech, Inc.**  
 A wholly owned subsidiary of EVAPCO, Inc.  
 Lenexa, KS USA  
 913-322-5165 p  
 marketing@evaptech.com

**Tower Components, Inc.**  
 A wholly owned subsidiary of EVAPCO, Inc.  
 Ramseur, NC USA  
 336-824-2102 p  
 mail@towercomponentsinc.com

**EVAPCO Alcoi, Inc.**  
 A wholly owned subsidiary of EVAPCO, Inc.  
 York, PA USA  
 717-347-7500 p  
 info@alcoi.net

**Europe**

**EVAPCO Europe BVBA**  
**European Headquarters**  
 Heersterveldweg 19  
 Industrieterrein Oost  
 3700 Tongeren, Belgium  
 (32) 12-395029 p | (32) 12-238527 f  
 evapco.europe@evapco.be

**EVAPCO Europe, S.r.l.**  
 Milan, Italy  
 (39) 02-939-9041 p  
 evapcoeuropa@evapco.it

**EVAPCO Europe, S.r.l.**  
 Sondrio, Italy

**EVAPCO Europe GmbH**  
 Meerbusch, Germany  
 (49) 2159 6956 18 p  
 info@evapco.de

**EVAPCO Air Solutions**  
 A wholly owned subsidiary of EVAPCO, Inc.  
 Aabybro, Denmark  
 (45) 9824 4999 p  
 info@evapco.dk

**EVAPCO Air Solutions GmbH**  
 Garbsen, Germany  
 (49) 5137 93875-0 p  
 info@evapcoas.de

**Evap Egypt Engineering Industries Co.**  
 A licensed manufacturer of EVAPCO, Inc.  
 Nasr City, Cairo, Egypt  
 2 02 24022866/2 02 24044997 p  
 primacool@link.net / shady@primacool.net

**EVAPCO S.A. (Pty.) Ltd.**  
 A licensed manufacturer of EVAPCO, Inc.  
 Isando 1600, Republic of South Africa  
 (27) 11-392-6630 p  
 evapco@evapco.co.za

**Asia/Pacific**

**EVAPCO Asia/Pacific Headquarters**  
 1159 Luoning Road  
 Baoshan Industrial Zone  
 Shanghai 200949, P.R. China  
 (86) 21-6687-7786 p | (86) 21-6687-7008 f  
 marketing@evapcochina.com

**EVAPCO (Shanghai) Refrigeration Equipment Co., Ltd.**  
 Baoshan Industrial Zone Shanghai, P.R. China  
 (86) 21-6687-7786 p  
 marketing@evapcochina.com

**Beijing EVAPCO Refrigeration Equipment Co., Ltd.**  
 Huairou District Beijing, P.R. China  
 010-6166-7238 p  
 evapcobj@evapcochina.com

**EVAPCO Australia (Pty.) Ltd.**  
 Riverstone NSW 2765, Australia  
 (61) 2 9627-3322 p  
 sales@evapco.com.au

**EVAPCO Composites Sdn. Bhd**  
 Rawang, Selangor, Malaysia  
 (60-3) 6092-2209 p

**EvapTech Asia Pacific Sdn. Bhd**  
 A wholly owned subsidiary of EvapTech, Inc.  
 Puchong, Selangor, Malaysia  
 (60-3) 8070-7255 p  
 marketing-ap@evaptech.com

**South America**

**EVAPCO Brasil**  
 Equipamentos Industriais Ltda.  
 Al. Vênus, 151 – CEP: 13347-659  
 Indaiatuba –São Paulo – Brasil  
 (55+11) 5681-2000 p  
 vendas@evapco.com.br

**Fan Technology Resource**  
 Cruz das Almas – Indaiatuba  
 São Paulo, Brasil 13308-200  
 55 (11) 4025-1670  
 fantr@fantr.com



www.evapco.com

©2018 EVAPCO, Inc.

Bulletin 131A  
400/0218/YGS

